

NOTES:

- 1. PART NO. HAS SUFFIX "B" OR "W" (BLACK OR WHITE).
- 2. BAG 5-007 IN A SEPARATE BAG.
- 3. APPLY DOW CORNING III.
- 4. APPLY LOCTITE 680.
- 5. ASSEMBLY HEIGHT OF ITEM SHALL BE DETERMINED BY WATER TEST. HANDLE SHALL HAVE SLIGHT PLAY (MOVEMENT UP AND DOWN).
- 6. WATER TEST WHOLE UNIT.
- 7. AFTER ASSEMBLY, THE DISTANCE BETWEEN THE TOP SURFACE OF ITEM 7 AND THE TOP SURFACE OF ITEM 6 MUST BE BETWEEN .056 -.070
- 8. USE 45 IN.LBS TO INSTALL ITEM # 10 ONTO # 2.

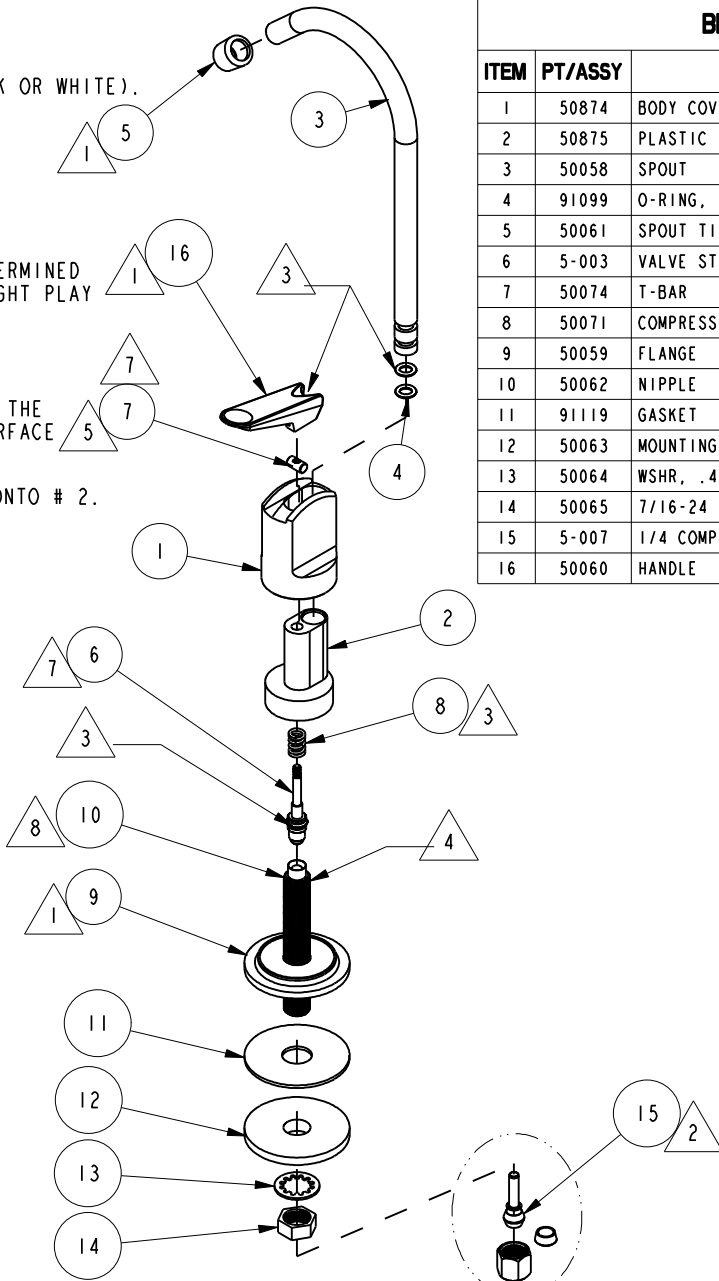

BILL OF MATERIAL (CURRENT LEVEL)

ITEM	PT/ASSY	DESCRIPTION	TYPE	QTY.
1	50874	BODY COVER	PART	1
2	50875	PLASTIC INSERT	PART	1
3	50058	SPOUT	PART	1
4	91099	O-RING, #2- 009, EPDM, 65-75 DURO, NSF-61	PART	2
5	50061	SPOUT TIP	PART	1
6	5-003	VALVE STEM ASM	ASSEMBLY	1
7	50074	T-BAR	PART	1
8	50071	COMPRESSION SPRING	PART	1
9	50059	FLANGE	PART	1
10	50062	NIPPLE	PART	1
11	91119	GASKET	PART	1
12	50063	MOUNTING WASHER	PART	1
13	50064	WSHR, .450 ID X .750 OD X .036 THK, INT. TOOTH, LOCK ,STL	PART	1
14	50065	7/16-24 NUT	PART	1
15	5-007	1/4 COMP KIT	ASSEMBLY	1
16	50060	HANDLE	PART	1

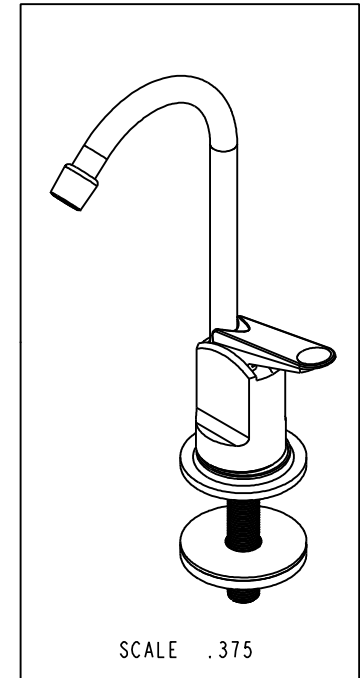

COPYRIGHT 2005 BRASSTECH, INC. THESE DRAWINGS AND THE DESIGNS DEPICTED HEREIN ARE THE PROPRIETARY PROPERTY OF BRASSTECH. ANY USE OR REPRODUCTION IS SUBJECT TO THE EXPRESS APPROVAL OF BRASSTECH. UNAUTHORIZED USE IS STRICTLY PROHIBITED. ALL RIGHTS RESERVED.

BRASSTECH
INCORPORATED
2001 E. CARNEGIE AVE.
SANTA ANA, CA 92705
(949) 417-5207

WATER DISPENSER FAUCET

ASSY. NO.

105

SCALE .313

REF. -

SHEET 1 OF 2

REV	REV DESC	DATE
D	EN-2601	09/16/13
C	EN-1529	04/20/10
B	EN-1095	09/15/08
A	EO-0777	10/23/06

SPECIFICATION DWG

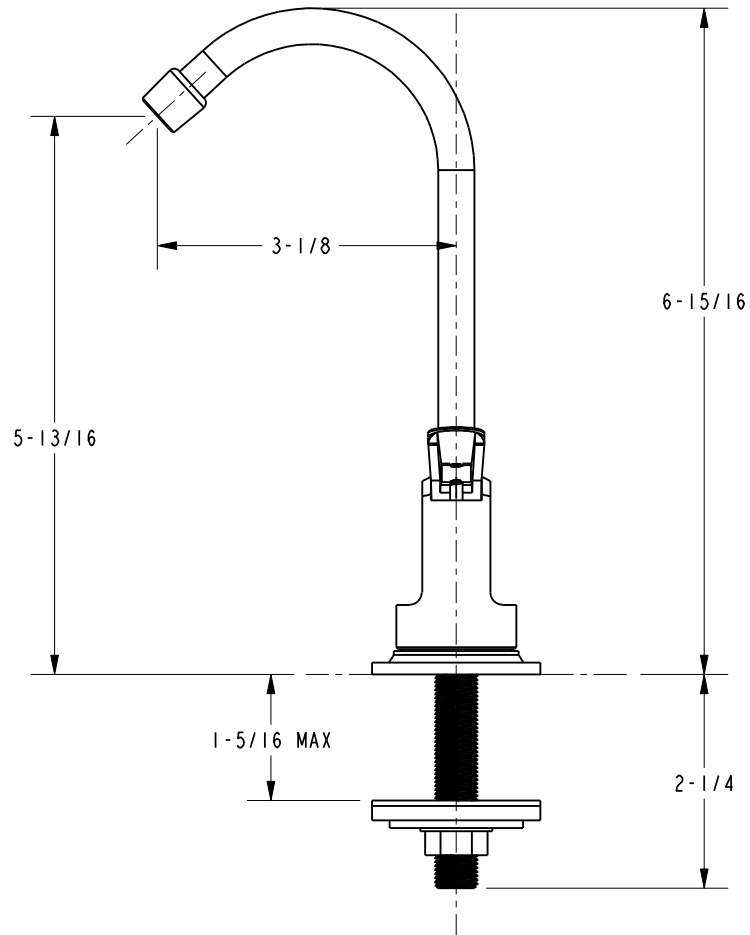
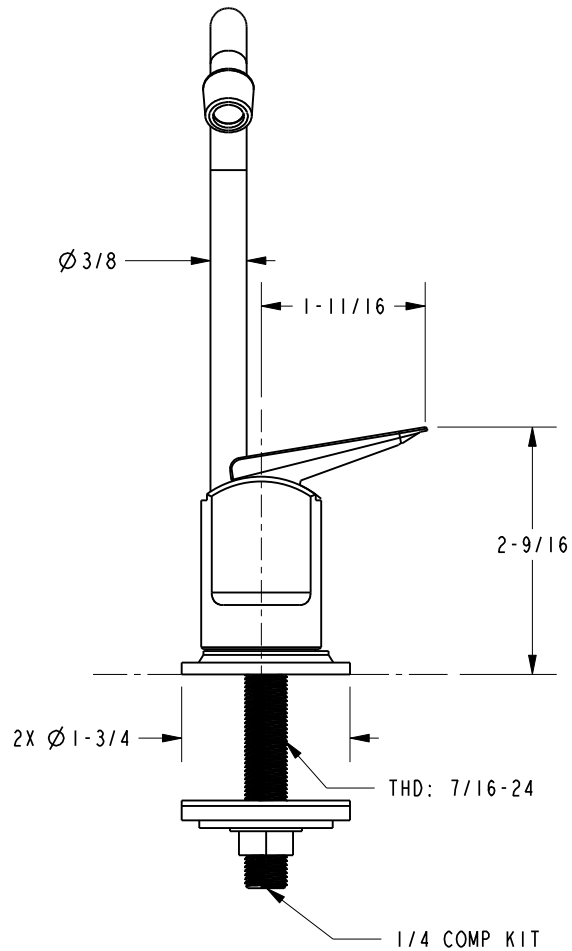

DIMENSIONS ARE IN INCHES AND AN APPROXIMATION OF A TYPICAL INSTALLATION

COPYRIGHT 2005 BRASSTECH, INC. THESE DRAWINGS AND THE DESIGNS DEPICTED HEREIN ARE THE PROPRIETARY PROPERTY OF BRASSTECH. ANY USE OR REPRODUCTION IS SUBJECT TO THE EXPRESS APPROVAL OF BRASSTECH. UNAUTHORIZED USE IS STRICTLY PROHIBITED. ALL RIGHTS RESERVED.

BRASSTECH		2001 CARNEGIE AVE. SANTA ANA, CA 92705 (949) 417-5207	
DWG NO.	105	REV	D
SCALE	.500	REF.	-
SHEET 2		OF 2	