

NOTES:

1. TO INSPECT ASSEMBLY, FOLLOW FIRST ARTICLE AND IN PROCESS INSPECTION SHEET.

2. APPLY 80-85 IN-LBS.

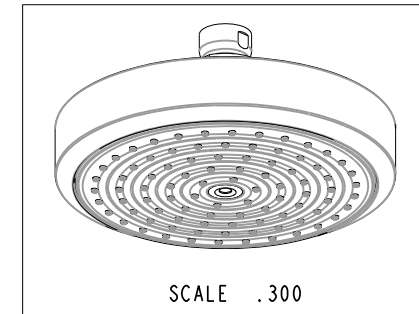
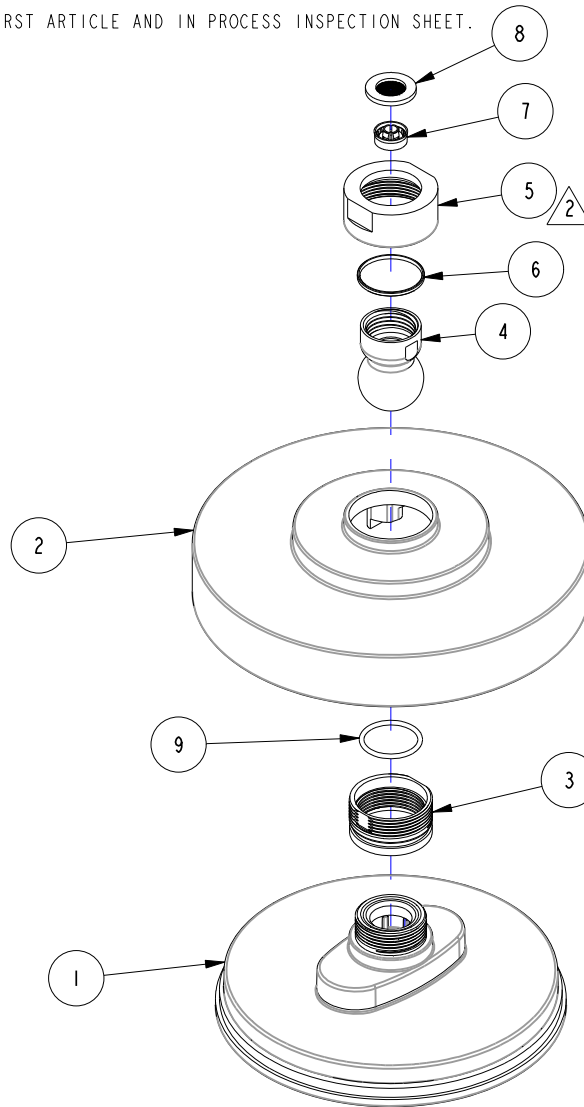

BILL OF MATERIAL (CURRENT LEVEL)				
ITEM	PT/ASSY	DESCRIPTION	TYPE	QTY.
1	1-200	SHOWER ENGINE, 1-JET	ASSEMBLY	1
2	13399	SHOWER ENGINE SHELL	PART	1
3	13401	SHOWER COLLAR ADAPTER	PART	1
4	80018	PIVOT BALL	PART	1
5	13403	SHOWER COLLAR NUT	PART	1
6	91157	WSHR, .920 ID X 1.0 OD X .066 THK, FLT, NYLON	PART	1
7	12833	FLOW REGULATOR, 1.8 GPM MAX	PART	1
8	91606	GASKET W/ FILTER SCREEN	PART	1
9	91023	O-RING, #2- 019, EPDM, 65-75 DURO, NSF 61	PART	1

-	F	EN-4149a	05/28/21	C.G.
-	E	EN-4300w	03/12/21	R.S.
-	D	EN-3999	10/17/19	C.G.
-	C	EN-3552	03/20/18	V.V.
-	B	EN-3410	12/29/17	C.G.
-	A	EN-1668	04/05/11	V.V.
-	-	EO-0894	10/18/07	-
ZONE	REV	DESCRIPTION	DATE	APPROVED

COPYRIGHT 2005 BRASSTECH, INC. THESE DRAWINGS AND THE DESIGNS DEPICTED HEREIN ARE THE PROPRIETARY PROPERTY OF BRASSTECH. ANY USE OR REPRODUCTION IS SUBJECT TO THE EXPRESS APPROVAL OF BRASSTECH. UNAUTHORIZED USE IS STRICTLY PROHIBITED. ALL RIGHTS RESERVED.

TESTING	-	-	-
ASSEMBLY	-	-	-
PLATING	-	3-2042BP	3-2042BP
POLISHING	-	NEXT ASSY	USED ON
MACHINING	-	APPLICATION	
TOOLING FIXTURE #	REMOVE ALL BURRS AND SHARP EDGES		

UNITS ARE: INCHES [MM]		
TOLERANCES ARE:		
FRACTIONS	DECIMALS	ANGLES
±1/16"	.X ±.1 [2.5]	±1°
	.XX ±.06 [1.5]	
(X.XXX) DENOTES CRITICAL DIMS. ALL THREADS ARE CRITICAL		
DRAWN	MANJUNATH	10/17/19
CHECKED	C.G.	10/17/19
APPROVED	C.G.	10/17/19

BRASSTECH 2001 CARNEGIE AVE. SANTA ANA, CA 92705 (949) 417-5207
INCORPORATED

CONTEMP. SHOWER HEAD - SINGLE JET

DWG NO. 2141

SCALE .350 REF. - SHEET 1 OF 2

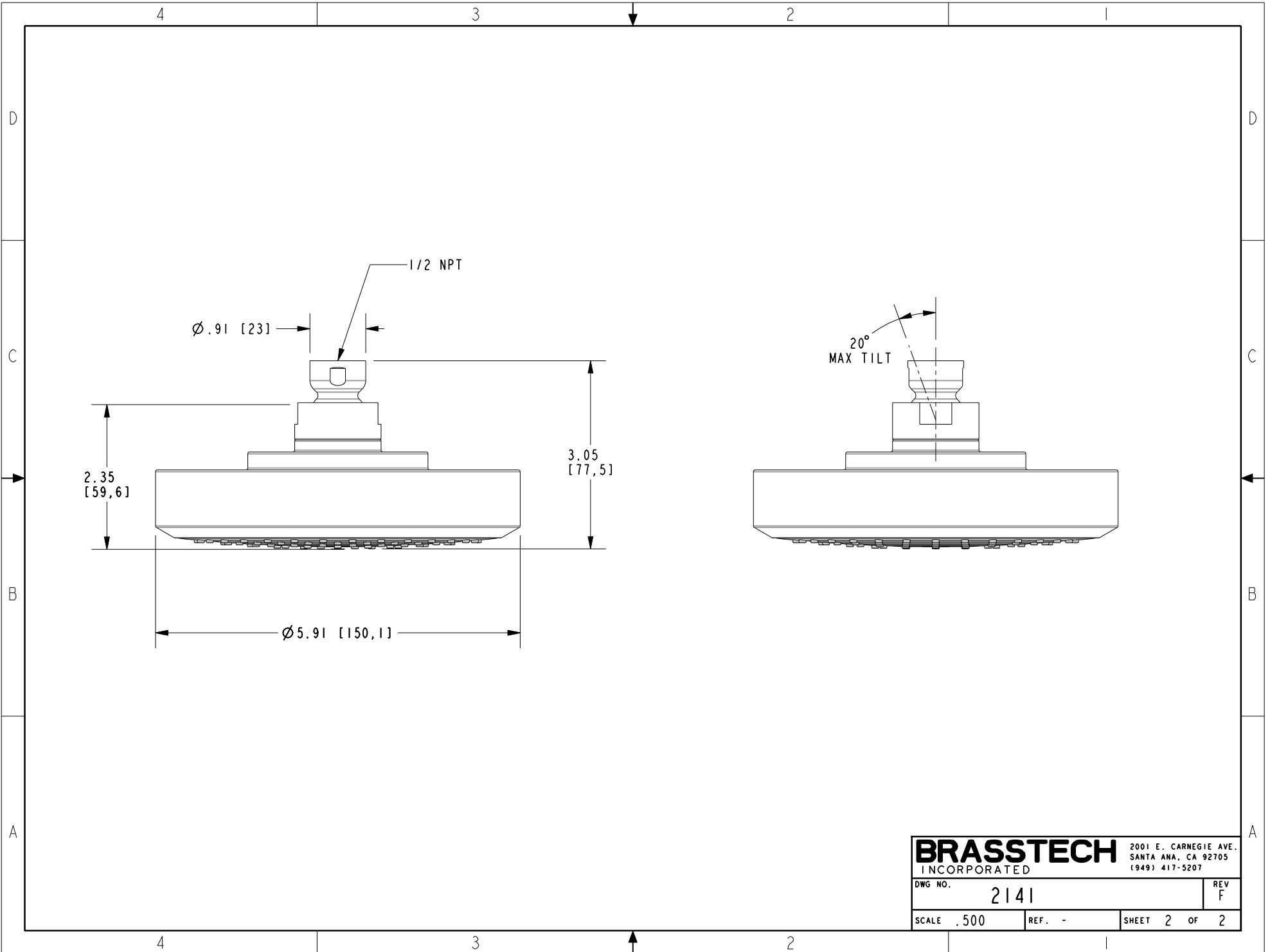

BRASSTECH		2001 E. CARNEGIE AVE. SANTA ANA, CA 92705 (949) 417-5207	
DWG NO.	2141	REV	F
SCALE .500	REF. -	SHEET 2	OF 2