

NOTES:

1. TO INSPECT ASSEMBLY, FOLLOW FIRST ARTICLE AND IN PROCESS INSPECTION SHEET.

2. APPLY LIGHT FILM OF SUPPER LUBE GREASE OR EQUIVALENT.

3. USE A 17 LB/IN TORQUE TO INSTALL.

4. APPLY LOCTITE 242.

5. APPLY ADHESIVE LOCTITE 680 OR EQUIVALENT.

BILL OF MATERIAL (CURRENT LEVEL)

ITEM	PT/ASSY	DESCRIPTION	TYPE	QTY.
1	11599	FLOW REGULATOR, 1.75 GPM, LIGHT BLUE	PART	1
2	11688	BODY SPRAY RETAINER	PART	1
3	11690	BODY SPRAY ESCUTCHEON	PART	1
4	11691	BODY SPRAY COLLAR	PART	1
5	11693	BODY SPRAY SHELL	PART	1
6	11694	BODY SPRAY FACE PLATE	PART	1
7	50199	PIVOT BALL	PART	1
8	91019	O-RING, #2- 014, EPDM, 65-75 DURO, NSF 61	PART	1
9	91153	WSHR .438 X .738	PART	1
10	91160	WSHR .5 ID X .74 OD X .25 THK, CONCAVED, RUBBER	PART	1
11	91259	O-RING, #2-121, EPDM, 65-75 DURO	PART	1
12	91432	O-RING, #2-016, PTFE, D55 DURO	PART	1
13	91520	JET SPRAY FACE PLATE	PART	1

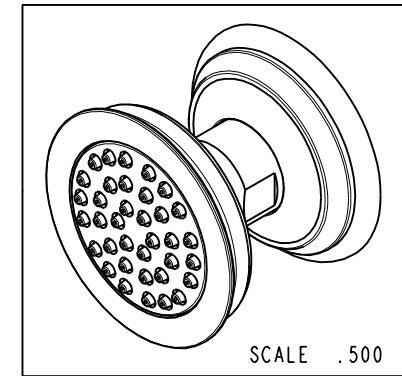
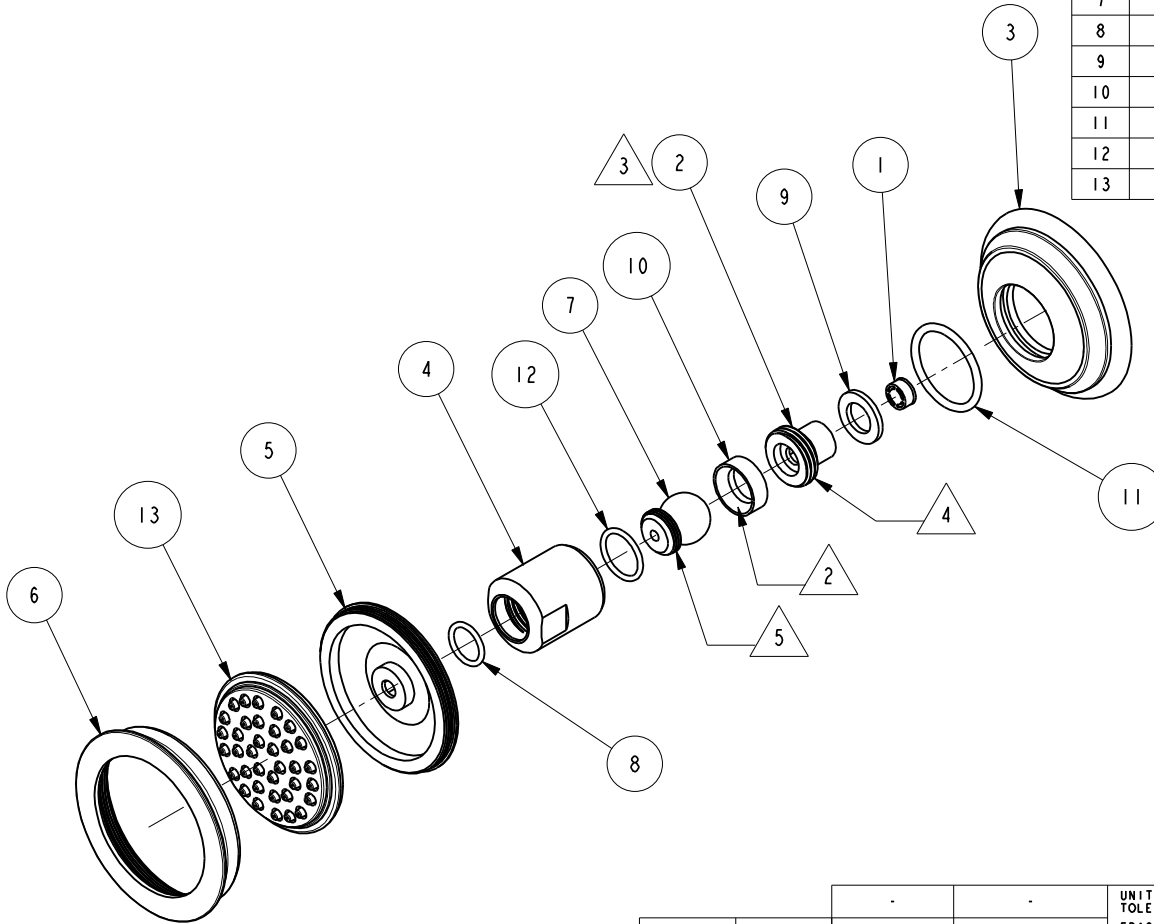

TESTING	-	-	-
ASSEMBLY	-	-	-
PLATING	-	-	-
POLISHING	-	NEXT ASSY	USED ON
MACHINING	-	APPLICATION	
TOOLING FIXTURE #	REMOVE ALL BURRS AND SHARP EDGES		

UNITS ARE: INCHES [MM]  
TOLERANCES ARE:  
FRACTIONS DECIMALS ANGLES  
±1/16" .X ±.1 [2.5] ±°  
.XX ±.06 [1.5]

(X.XXX) DENOTES CRITICAL DIMS.  
ALL THREADS ARE CRITICAL

DRAWN	JINSON	01/07/21
CHECKED	R.S.	01/07/21
APPROVED	R.S.	01/07/21

**BRASSTECH** 2001 CARNEGIE AVE.  
INCORPORATED SANTA ANA, CA 92705  
(949) 417-5207

SHOWER BODY SPRAY - TRAD.

ZONE	REV	DESCRIPTION	DATE	APPROVED
-	B	EN-4300d	01/07/21	R.S.
-	A	EN-2768	06/19/14	-
-	-	EN-1421	07/29/10	-

COPYRIGHT 2005 BRASSTECH, INC.  
THESE DRAWINGS AND THE DESIGNS  
DEPICTED HEREIN ARE THE PROPRIETARY  
PROPERTY OF BRASSTECH. ANY USE  
OR REPRODUCTION IS SUBJECT TO  
THE EXPRESS APPROVAL OF BRASSTECH.  
UNAUTHORIZED USE IS STRICTLY  
PROHIBITED. ALL RIGHTS RESERVED.

DWG NO.	2170	REV	B
SCALE	.400	REF.	-
SHEET	1	OF	2

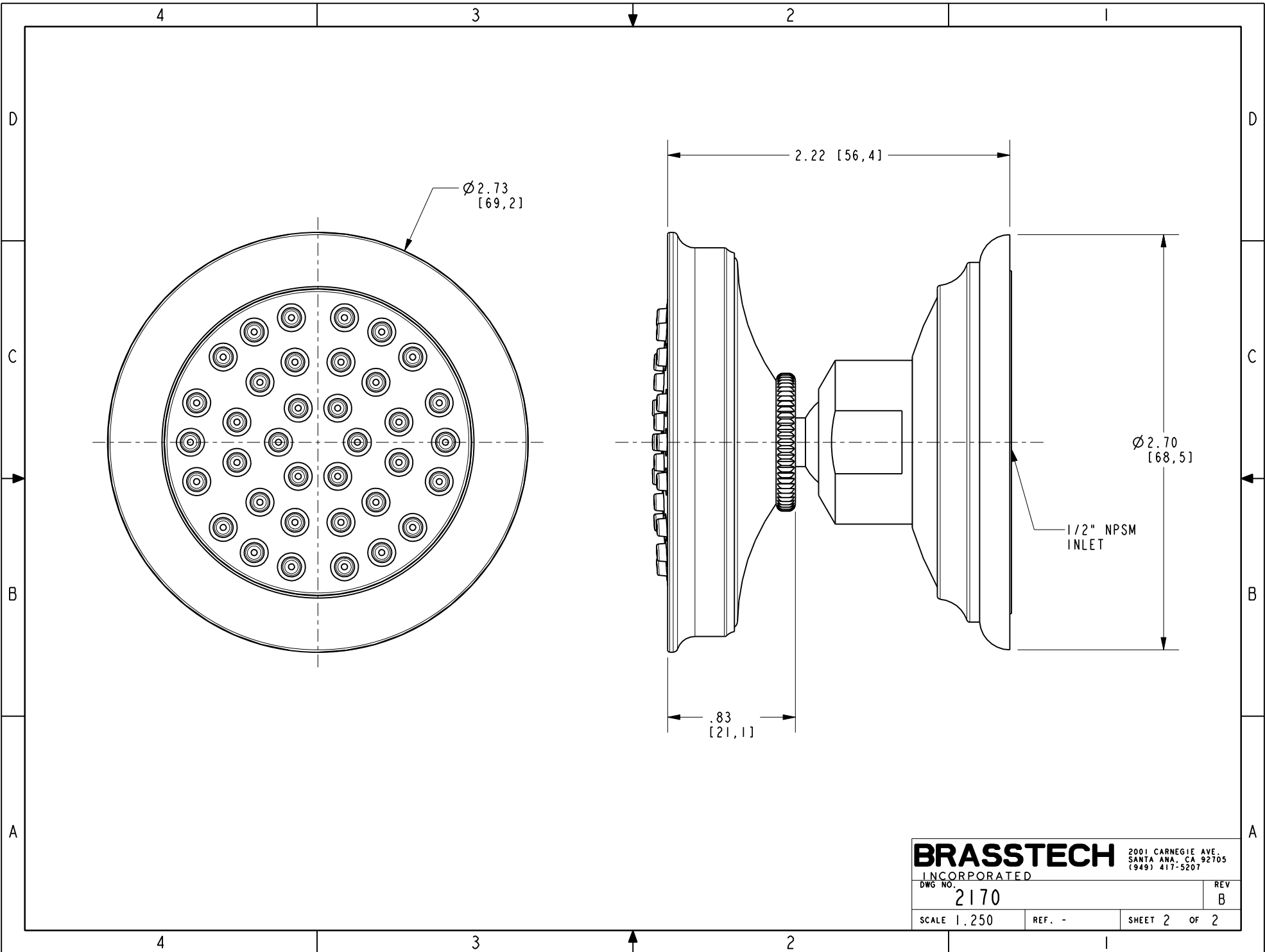

Ø 2.73  
[69,2]

2.22 [56,4]

Ø 2.70  
[68,5]

1/2" NPSM  
INLET

.83  
[21,1]

<b>BRASSTECH</b>		2001 CARNEGIE AVE. SANTA ANA, CA 92705 (949) 417-5207	
INCORPORATED			
DWG NO.	2170	REV	B
SCALE	1.250	REF.	-
		SHEET	2 OF 2