

NOTES:

- (N1) 1. TO INSPECT ASSEMBLY, FOLLOW FIRST ARTICLE AND IN PROCESS INSPECTION SHEET.

BILL OF MATERIAL (CURRENT LEVEL)

ITEM	PT/ASSY	DESCRIPTION	TYPE	QTY.
1	1-683	POP UP BODY ASM	ASSEMBLY	1
2	20-261	FLANGE ASM	ASSEMBLY	1
3	12531	DRAIN CAP	PART	1
4	91642	O-RING	PART	1

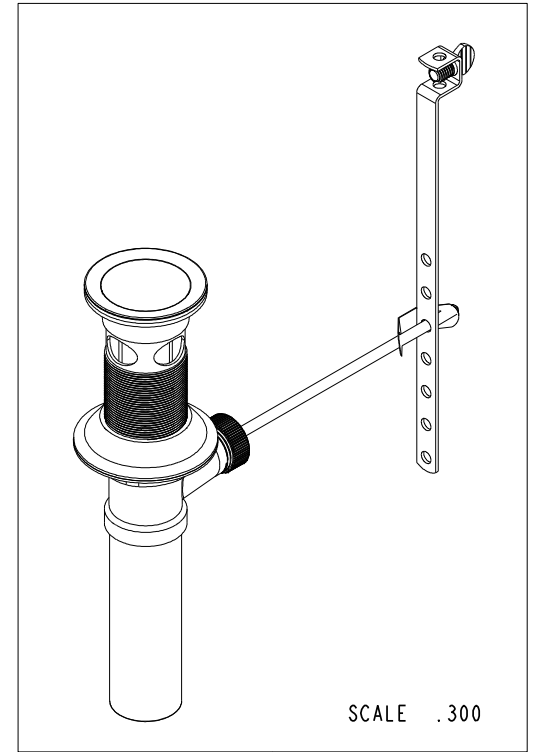
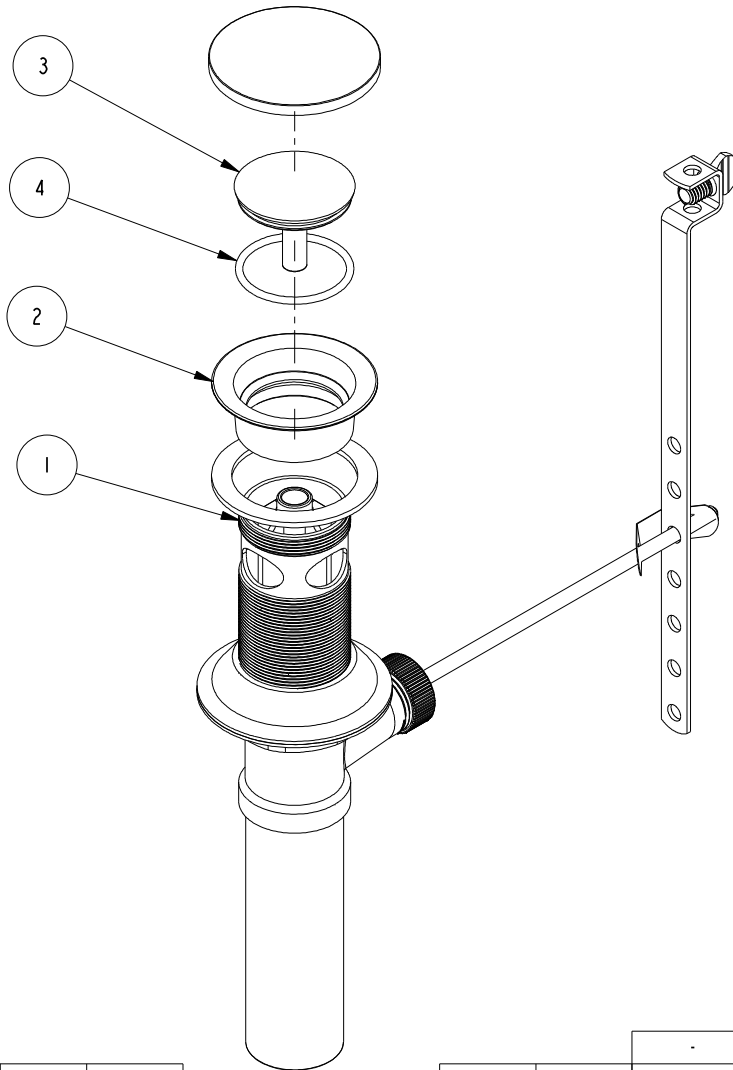

-	D	EN-430011	10/22/21	N.S.
-	C	EN-3248	01/18/17	V.V.
-	B	EN-3079	09/06/16	V.V.
-	A	EN-1713	03/29/12	V.V.
-	-	RELEASED	12/22/04	V.V.
ZONE	REV	DESCRIPTION	DATE	APPROVED

COPYRIGHT 2005 BRASSTECH, INC. THESE DRAWINGS AND THE DESIGNS DEPICTED HEREIN ARE THE PROPRIETARY PROPERTY OF BRASSTECH. ANY USE OR REPRODUCTION IS SUBJECT TO THE EXPRESS APPROVAL OF BRASSTECH. UNAUTHORIZED USE IS STRICTLY PROHIBITED. ALL RIGHTS RESERVED.

TESTING	-	-	-
ASSEMBLY	-	-	-
PLATING	-	-	-
POLISHING	-	NEXT ASSY	USED ON
MACHINING	-	APPLICATION	
TOOLING FIXTURE #	REMOVE ALL BURRS AND SHARP EDGES		

UNITS ARE: INCHES [MM]
TOLERANCES ARE:
FRACTIONS DECIMALS ANGLES
±1/16" .X ±.1 [2.5] ±1°
.XX ±.06 [1.5]

(X.XXX) DENOTES CRITICAL DIMS.
ALL THREADS ARE CRITICAL

DRAWN	H. LE	06/13/16
CHECKED	V. VU	06/13/16
APPROVED	V. VU	06/13/16

BRASSTECH
INCORPORATED

2001 CARNEGIE AVE.
SANTA ANA, CA 92705
(949) 417-5207

POP UP ASSEMBLY

DWG NO.	325	REV	D
SCALE	.406	REF.	-
SHEET	1	OF	2

