

NOTES:

1. TO INSPECT ASSEMBLY, FOLLOW FIRST ARTICLE AND IN PROCESS INSPECTION SHEET.
2. APPLY LOCTITE 242 TO THREADS.
3. TORQUE TO 135 +/-5 LB-IN.
4. PUT THESE ITEMS IN SEPARATE PLASTIC BAGS.
5. TORQUE TO 7 +/-2 LB-IN.
6. PARTIALLY THREAD MOUNTING KIT ONTO SHANK.
7. APPLY THIN COAT OF SILICON GREASE

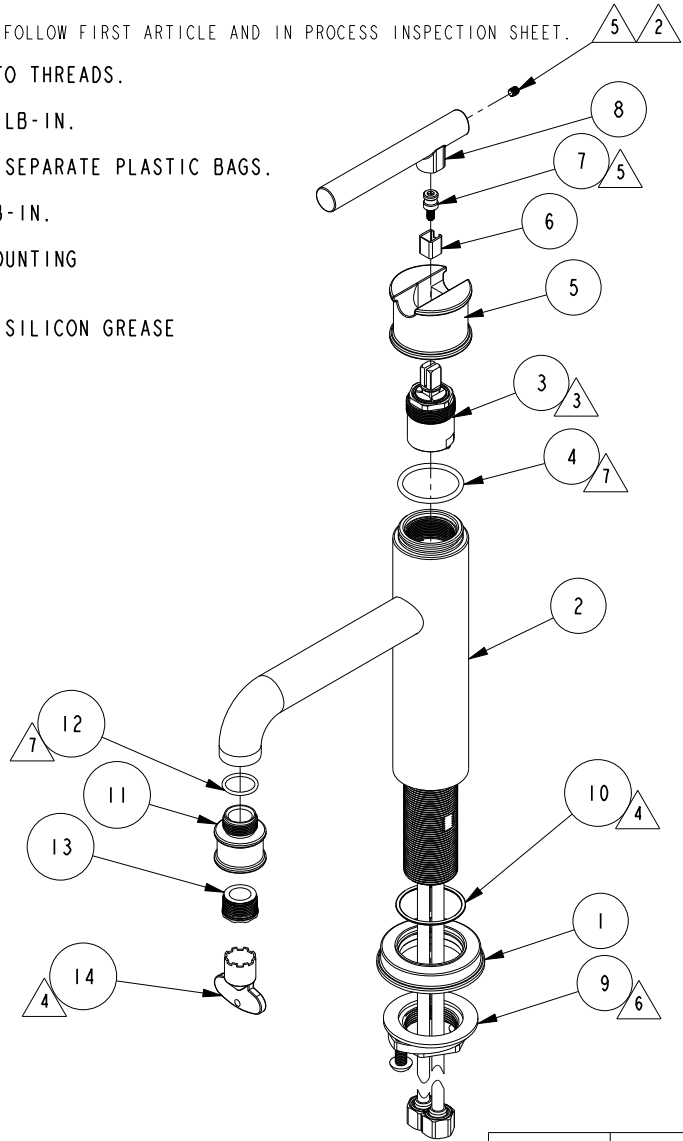

BILL OF MATERIAL (CURRENT LEVEL)

ITEM	PT/ASSY	DESCRIPTION	TYPE	QTY.
1	20-716	ESCUTCHEON ASM	ASSEMBLY	1
2	3-788	SPOUT BODY ASM	ASSEMBLY	1
3	1-371	CARTRIDGE	PART	1
4	91505	O-RING, #2-123, EPDM, 65-75 DURO	PART	1
5	13874	HANDLE HUB, CONTEMP	PART	1
6	91534	CARTRIDGE STEM INSERT	PART	1
7	11874	HANDLE ADAPTER SCREW	PART	1
8	20-389	HANDLE ASM	ASSEMBLY	1
9	1-393	1-1/8 18 UNEF MOUNTING KIT	ASSEMBLY	1
10	91764	O-RING, #2-027, EP, 50 DURO - GREY	PART	1
11	13876	AERATOR SHELL	PART	1
12	91020	O-RING, #2-016, EPDM, 65-75 DURO, NSF 61	PART	1
13	12407	CACHE AERATOR INSERT, TINY Jr. SIZE, 1.2 GPM	PART	1
14	91571	AERATOR KEY	PART	1

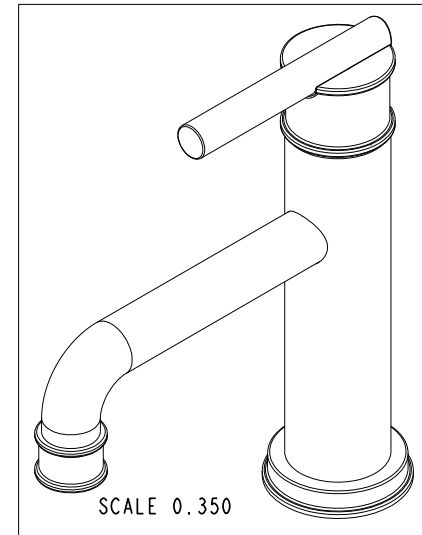

TESTING	-	-	-
ASSEMBLY	-	-	-
PLATING	-	-	-
POLISHING	-	NEXT ASSY	USED ON
MACHINING	-	APPLICATION	
TOOLING FIXTURE #		REMOVE ALL BURRS AND SHARP EDGES	

**BRASSTECH** 2001 CARNEGIE AVE.  
INCORPORATED SANTA ANA, CA 92705  
(949) 417-5207

SINGLE HOLE FAUCET

DWG NO. 3273

SCALE 0.250 REF. - SHEET 1 OF 2

COPYRIGHT 2005 BRASSTECH, INC. THESE DRAWINGS AND THE DESIGNS DEPICTED HEREIN ARE THE PROPRIETARY PROPERTY OF BRASSTECH. ANY USE OR REPRODUCTION IS SUBJECT TO THE EXPRESS APPROVAL OF BRASSTECH. UNAUTHORIZED USE IS STRICTLY PROHIBITED. ALL RIGHTS RESERVED.

EN-4598	01/03/23	J.M.		
ZONE	REV	DESCRIPTION	DATE	APPROVED

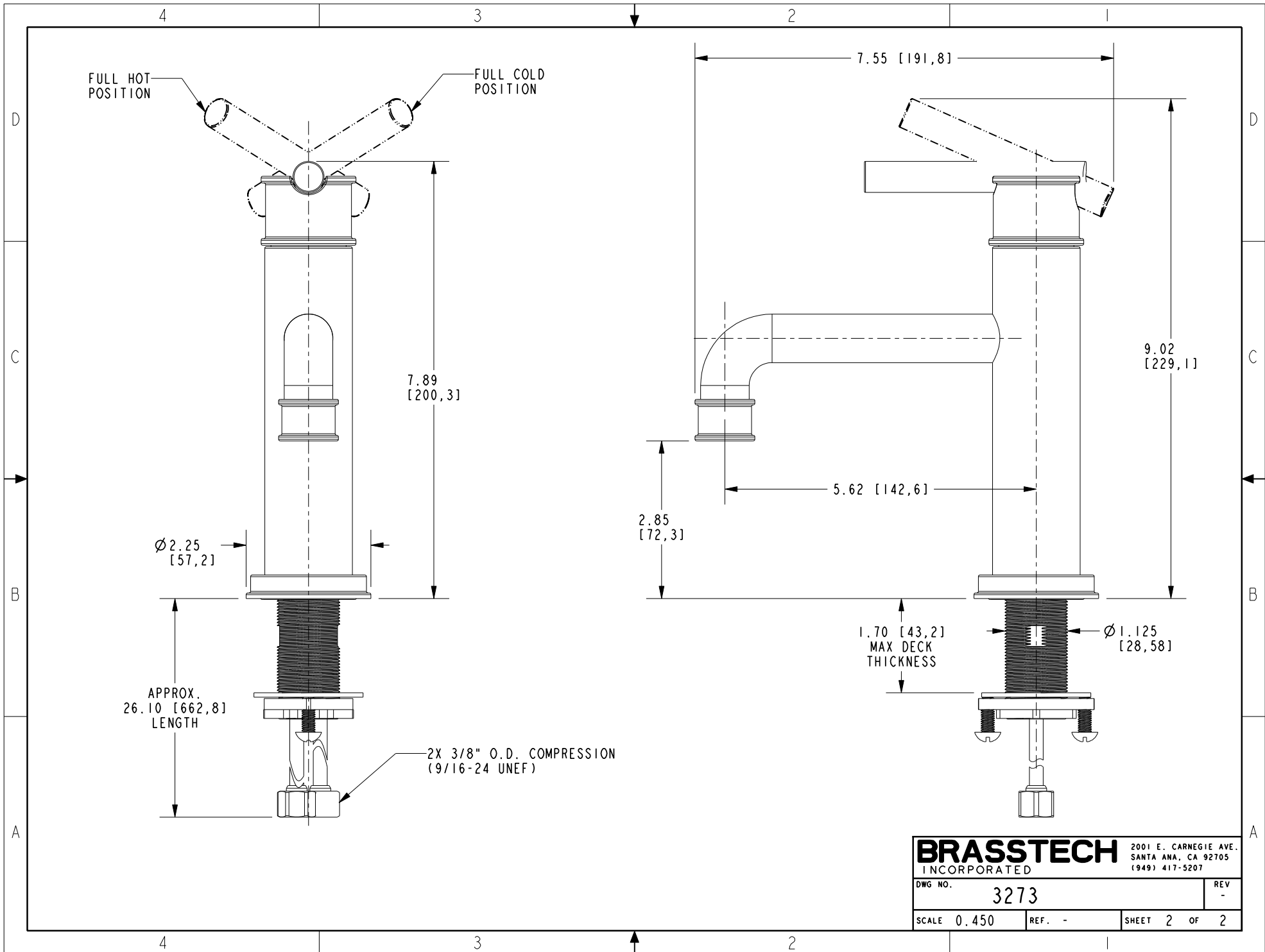

<b>BRASSTECH</b>		2001 E. CARNEGIE AVE.	
INCORPORATED		SANTA ANA, CA 92705	
DWG NO. 3273		REV -	
SCALE 0.450	REF. -	SHEET 2 OF 2	