

Prep Sink / Bar Faucet

1688



Features

- Solid brass construction
- Forged brass body with integral rotating spout and handles
- Quarter-turn washerless ceramic disc valve cartridges
- ADA compliant traditional cross handles
- Rotating spout assembly with integral supply hoses
- 7-5/16" (18.6 cm) spout height at outlet
- 8-7/16" (21.4 cm) spout reach (c-c)
- For single hole configurations
- 1.5 gallons (5.7 liters) per minute maximum flow rate

Codes / Standards Compliance

Meets or exceeds the following at date of manufacture:

- ASME A112.18.1/CSA B125.1
- IAPMO/cUPC
- IPC
- NSF 61
- ADA
- ICC/ANSI A117.1
- Energy Policy Act of 1992
- All applicable US Federal and State material regulations

Colors / Finishes

- 10B: Oil Rubbed Bronze
- 15: Polished Nickel
- 15S: Satin Nickel - PVD
- 26: Polished Chrome
- Other: Refer to the Newport Brass catalog for additional color/finish options.

Specified Model

Model	Description	Colors Finishes
1688	Two-Handle Prep Sink / Bar Faucet	<input type="checkbox"/> 10B <input type="checkbox"/> 15 <input type="checkbox"/> 15S <input type="checkbox"/> 26 <input type="checkbox"/> Other

Product Specification: Add "Color / Finish" suffix to Model number, below.

The Two-Handle Prep Sink / Bar Faucet shall be made of solid brass construction. Faucet shall feature a forged brass body incorporating quarter-turn washerless ceramic disc valve cartridges. Faucet shall have a 1.5 gallon (5.7 liter) per minute maximum flow rate. Product shall accommodate single hole configurations. Product shall incorporate a 7-5/16" (18.6 cm) spout height at outlet and a 8-7/16" (21.4 cm) spout reach (c-c). Faucet shall incorporate ADA compliant traditional cross handles. Prep Sink / Bar Faucet shall be Newport Brass Model 1688/_____.

1688

PRODUCT DIMENSIONS *(Units are in inches)*

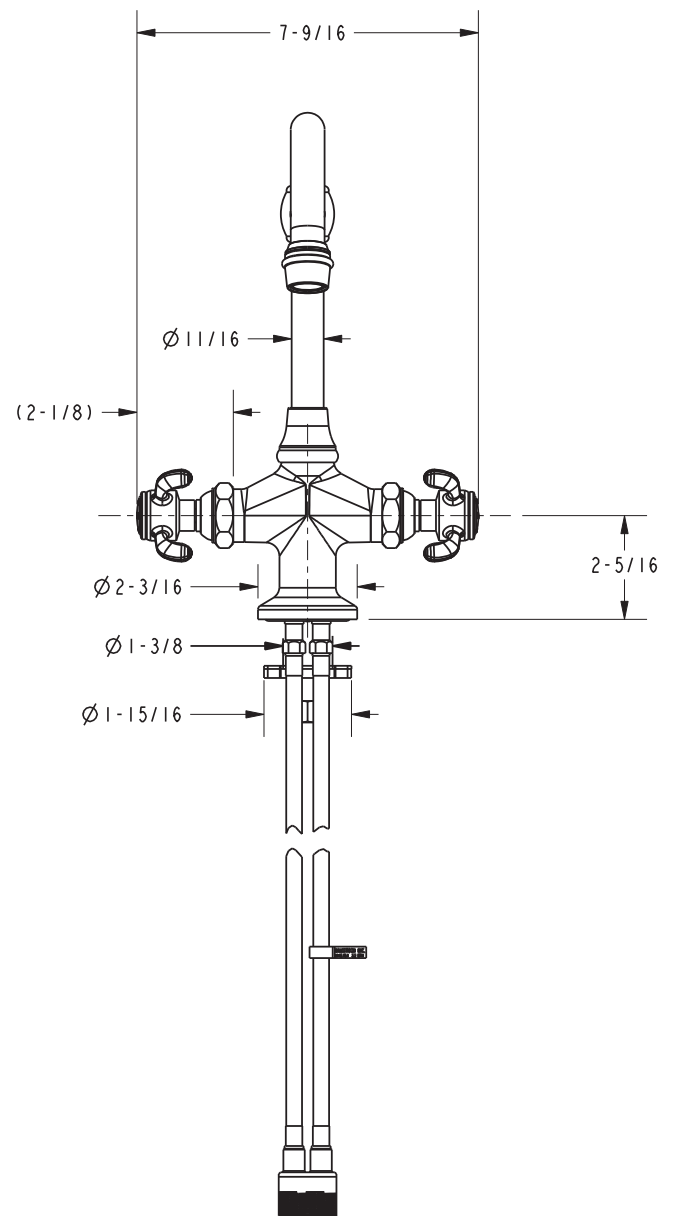
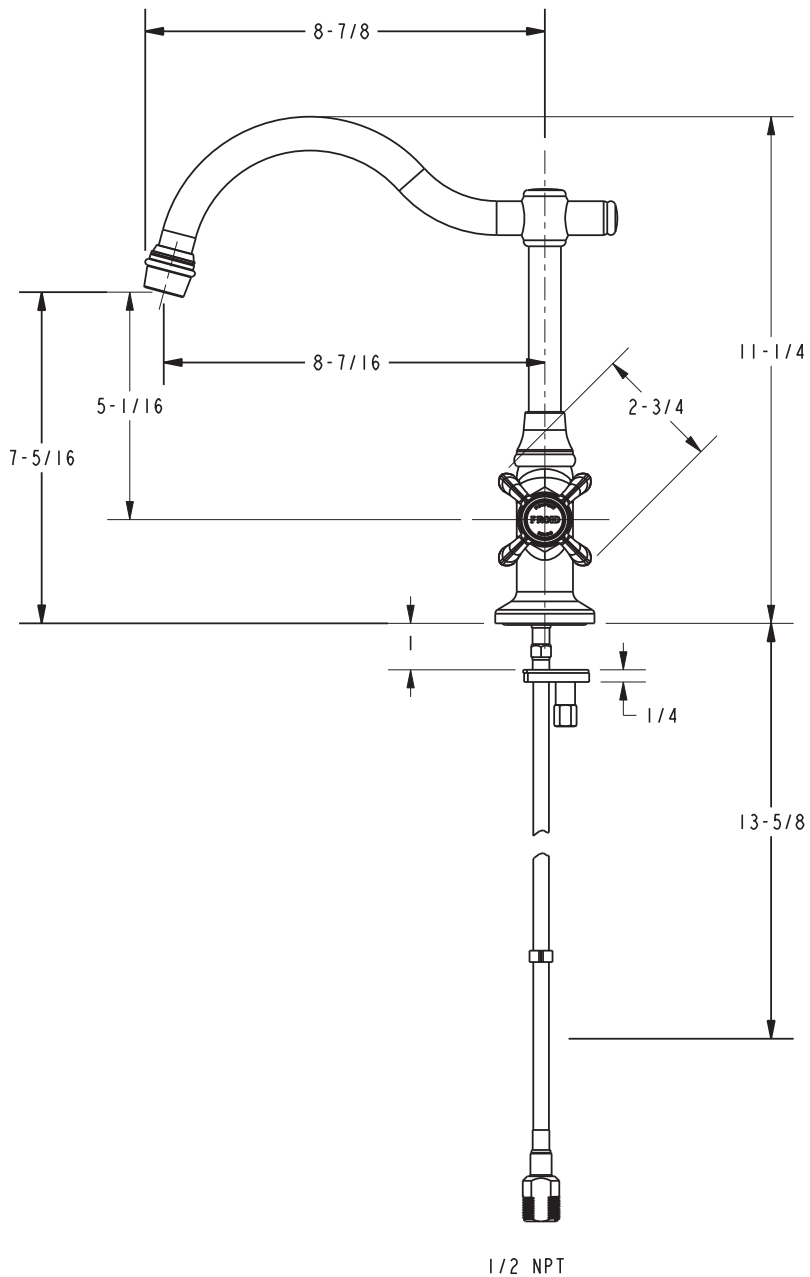

Virginia Prep Sink / Bar Faucet 1688