

NOTES:

1. TO INSPECT ASSEMBLY, FOLLOW FIRST ARTICLE AND IN PROCESS INSPECTION SHEET.

BILL OF MATERIAL (CURRENT LEVEL)

ITEM	PT/ASSY	DESCRIPTION	TYPE	QTY.
1	1-209	BP VALVE ASM WITH DIVERTER	ASSEMBLY	1
2	1-423	STEM KIT	ASSEMBLY	1

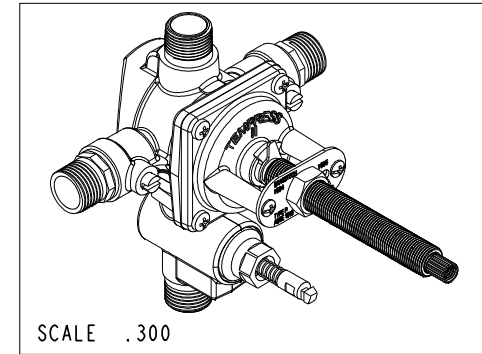
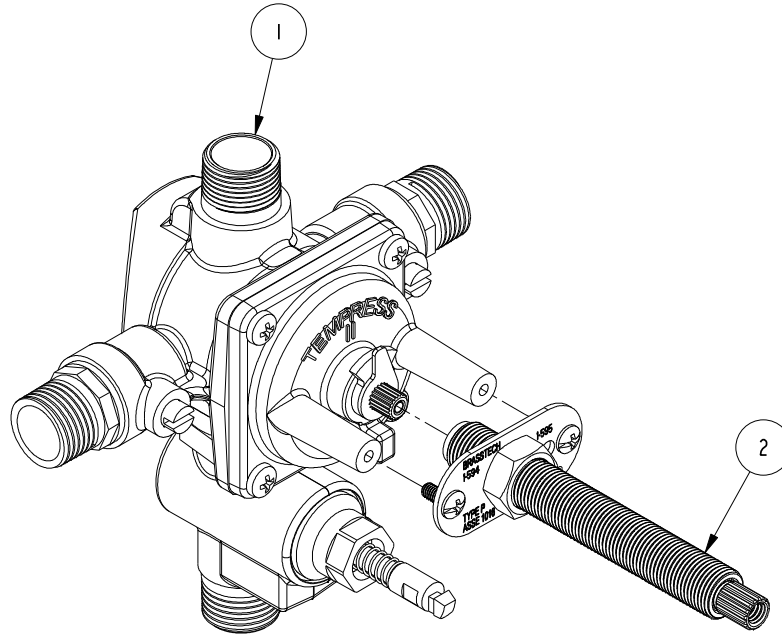

-	E	EN-4300kk	03/24/21	R. S.
-	D	EN-3729b	01/31/20	J. M.
-	C	EN-3285	03/15/17	J. A.
-	B	EN-2600	09/23/13	-
-	A	EN-2034	01/03/12	-
-	-	EN-1183	03/23/09	-
ZONE	REV	DESCRIPTION	DATE	APPROVED

COPYRIGHT 2005 BRASSTECH, INC. THESE DRAWINGS AND THE DESIGNS DEPICTED HEREIN ARE THE PROPRIETARY PROPERTY OF BRASSTECH. ANY USE OR REPRODUCTION IS SUBJECT TO THE EXPRESS APPROVAL OF BRASSTECH. UNAUTHORIZED USE IS STRICTLY PROHIBITED. ALL RIGHTS RESERVED.

TESTING	-	-	-
ASSEMBLY	-	-	-
PLATING	-	1032BP	1032BP
POLISHING	-	NEXT ASSY	USED ON
MACHINING	-	APPLICATION	
TOOLING FIXTURE #	REMOVE ALL BURRS AND SHARP EDGES		

UNITS ARE: INCHES [MM]		
TOLERANCES ARE:		
FRACTIONS	DECIMALS	ANGLES
±1/16"	.X ±.1 [2.5]	±1°
	.XX ±.06 [1.5]	
(X.XXX) DENOTES CRITICAL DIMS. ALL THREADS ARE CRITICAL		
DRAWN	JIMSON	03/15/17
CHECKED	RAVINDRA	03/15/17
APPROVED	J.A.	03/15/17

BRASSTECH		2001 CARNEGIE AVE. SANTA ANA, CA 92705 (949) 417-5207	
INCORPORATED			
BP VALVE ASM WITH DIVERTER			
DWG NO.		REV	
1-595		E	
SCALE	REF.	SHEET	OF
.500	-	1	2

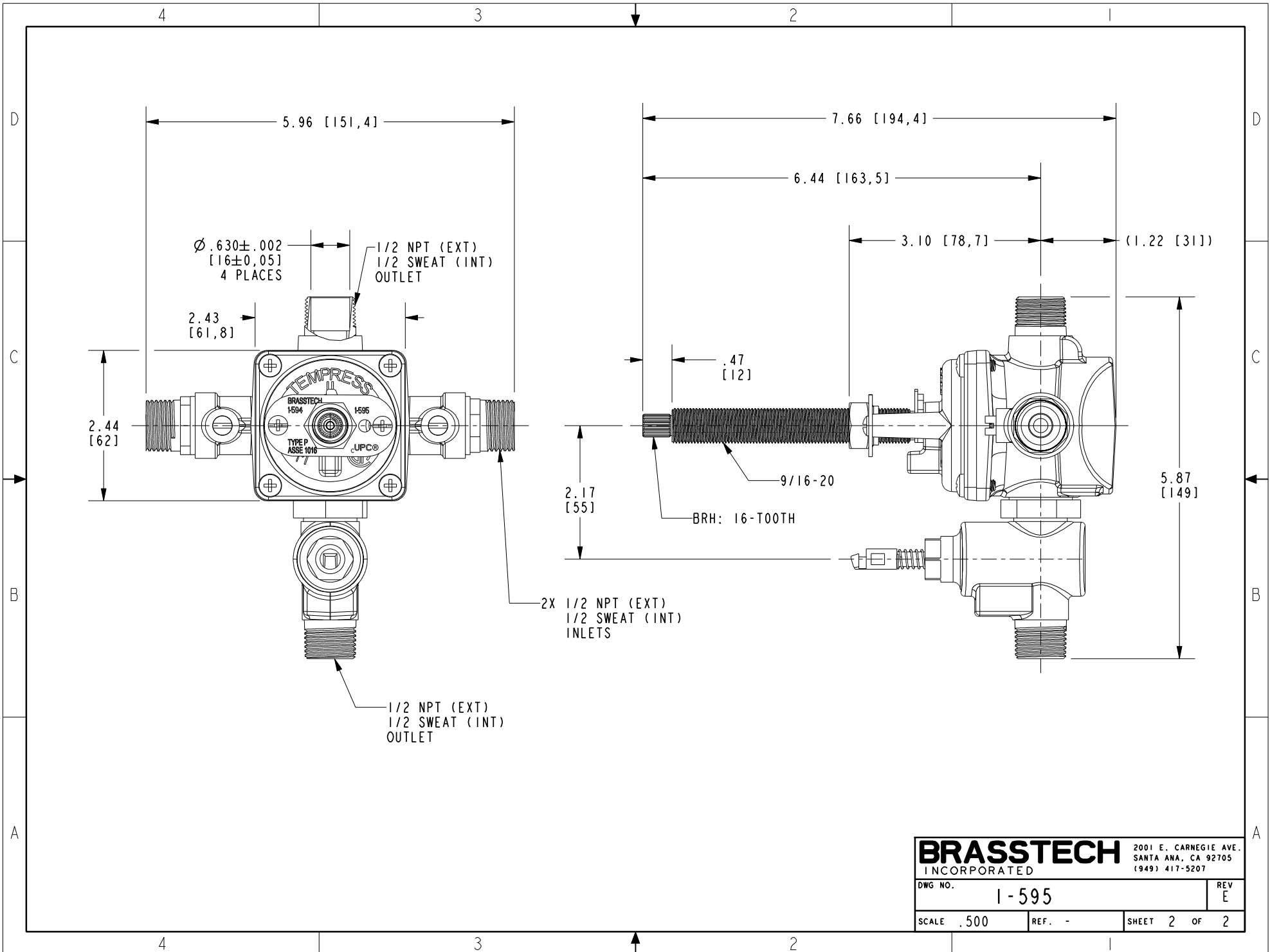

BRASSTECH		2001 E. CARNEGIE AVE. SANTA ANA, CA 92705 (949) 417-5207	
DWG NO.	1-595	REV	E
SCALE	.500	REF.	-
SHEET 2		OF 2	