

NOTES:

1. TO INSPECT ASSEMBLY, FOLLOW FIRST ARTICLE AND IN PROCESS INSPECTION SHEET.

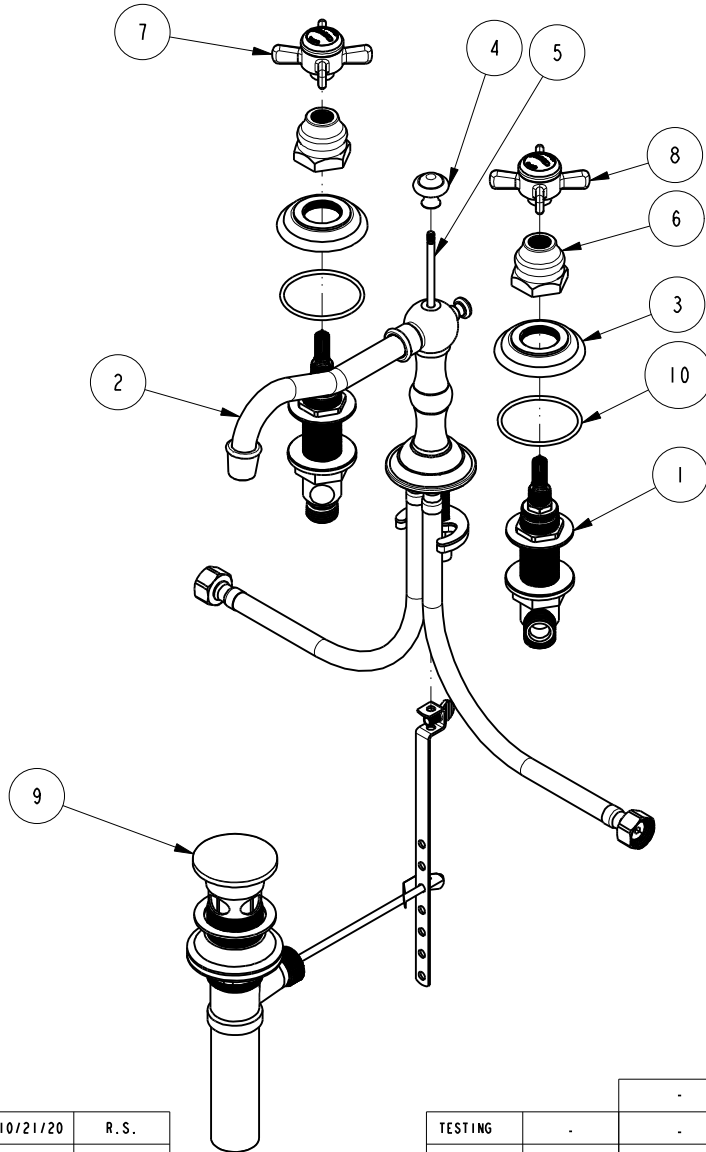

BILL OF MATERIAL (CURRENT LEVEL)

ITEM	PT/ASSY	DESCRIPTION	TYPE	QTY.
1	1-525	W/S VALVE ASM	ASSEMBLY	1
2	3-360	WIDE SPREAD SPOUT ONLY	ASSEMBLY	1
3	10048	ESCUTCHEON W/S VALVE	PART	2
4	10289	POP-UP KNOB	PART	1
5	10288	3/16" POP UP ROD	PART	1
6	10523	HEX ESCUTCHEON BONNET	PART	2
7	2-114	THIN BLADE X - HANDLE HOT	ASSEMBLY	1
8	2-115	THIN BLADE X - HANDLE COLD	ASSEMBLY	1
9	325	POP UP ASSEMBLY	ASSEMBLY	1
10	91753	O-RING, # 2-136, EP, 50 DURO - GREY	PART	2

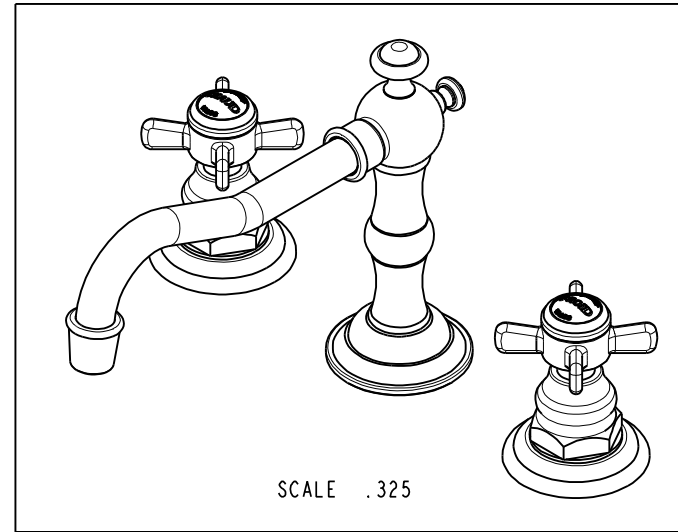

ZONE	REV	DESCRIPTION	DATE	APPROVED
-	D	EN-4300m	10/21/20	R.S.
-	C	EN-2334	12/19/12	-
-	B	EN-1616	09/13/10	-
-	A	EO-1051	07/28/08	-
-	-	RELEASED	PRE '95	-

COPYRIGHT 2005 BRASSTECH, INC. THESE DRAWINGS AND THE DESIGNS DEPICTED HEREIN ARE THE PROPRIETARY PROPERTY OF BRASSTECH. ANY USE OR REPRODUCTION IS SUBJECT TO THE EXPRESS APPROVAL OF BRASSTECH. UNAUTHORIZED USE IS STRICTLY PROHIBITED. ALL RIGHTS RESERVED.

TESTING	ASSEMBLY	PLATING	POLISHING	MACHINING	TOOLING FIXTURE #	APPLICATION
-	-	-	-	-	-	REMOVE ALL BURRS AND SHARP EDGES
-	-	-	-	-	-	-
-	-	-	-	-	-	-
-	-	-	-	-	-	-
-	-	-	-	-	-	-

UNITS ARE: INCHES [MM]		
TOLERANCES ARE:		
FRACTIONS	DECIMALS	ANGLES
±1/16"	.X ±.1 [2,5]	±°
	.XX ±.06 [1,5]	
(X.XXX) DENOTES CRITICAL DIMS.		
ALL THREADS ARE CRITICAL		
DRAWN	JINSON	10/21/20
CHECKED	R.S.	10/21/20
APPROVED	R.S.	10/21/20

BRASSTECH 2001 CARNEGIE AVE. SANTA ANA, CA 92705 (949) 417-5207
INCORPORATED

WIDE SPREAD WITH BLADE X - HDL

DWG NO. **1000** REV **D**

SCALE **.200** REF. - SHEET **1** OF **2**

