

NOTES:

1. TO INSPECT ASSEMBLY, FOLLOW FIRST ARTICLE AND IN PROCESS INSPECTION SHEET.

- 2. APPLY LOCTITE 680.
- 3. CUT AND SHORTEN O-RING BY .13" TO .20" IN LENGTH BEFORE INSTALLING.
- 4. SLIT O-RING BEFORE INSTALLING.
- 5. APPLY LOCTITE 242.
- 6. CONNECT CLEAR AND RED TUBINGS TOGETHER AND WATER TEST WHOLE UNIT.
- 7. BAG 92194 IN A SEPARATE BAG.
- 8. REWORK CARTRIDGE ASSY IF THE HANDLE DOES NOT RETURN TO THE "OFF" POSITION AUTOMATICALLY AFTER WATER TESTING.
- 9. INSTALLATION TORQUE: 8-14 LB-FT.
- 10. INSTALLATION TORQUE: 78 LB-IN +/- 6 LB-IN
- 11. LUBRICATE SPRING WITH DOW CORNING III.V
- 12. APPLY THIN FILM OF DOW CORNING III.
- 13. INSTALLATION TORQUE: 10-14 LB-IN

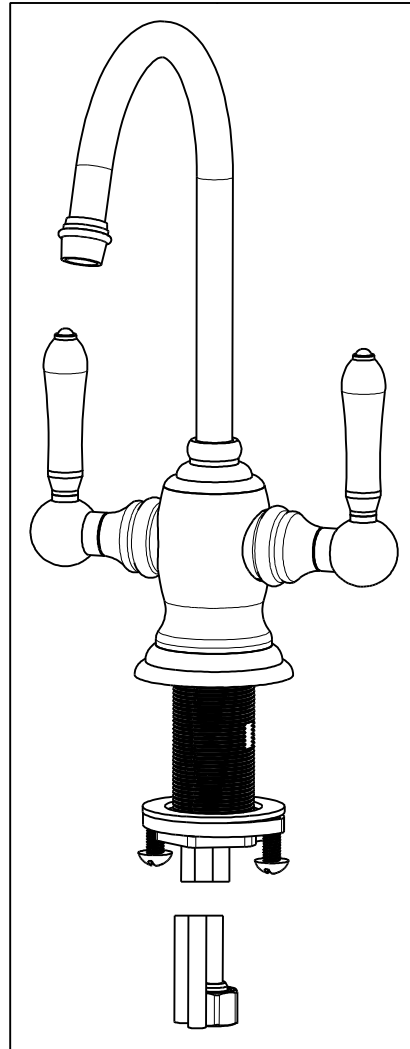

BILL OF MATERIAL (CURRENT LEVEL)

ITEM	PT/ASSY	DESCRIPTION	TYPE	QTY.
1	12716	ESCUTCHEON	PART	1
2	13282	WATER DISP. BODY H/C (TRAD)	PART	1
3	50705	WATER DISP BODY CAP	PART	1
4	50706	WATER DISP SPOUT RET RING	PART	1
5	50713	SPOUT, WATER DISP. (TRAD.)	PART	1
6	50712	WATER DISP SPOUT SHELL	PART	1
7	91382	O-RING, #2- 012, TEFLON,	PART	1
8	91217	O-RING, #2-020, EPDM, 65-75 DURO, NSF 61	PART	1
9	91017	O-RING, #2- 012, EPDM, 65-75 DURO, NSF 61	PART	2
10	50714	WATER DISP. CAR.T HOLDER	PART	2
11	1-134	CARTR 3/8 HOT 1/4 TR	PART	1
12	5-061	ADAPTER/CARTRIDGE ASSY	ASSEMBLY	1
13	50708	WATER DISP HDL BONNET (TRAD)	PART	2
14	91383	O-RING, #2- 014, TEFLON, NSF 61	PART	1
15	92194	COUPLING, 3/8" X 1/4"	PART	1
16	98043	TAG LABEL, HOT WATER WARNING	PART	1
17	91762	O-RING, #2-132, EP, 50 DURO - GREY	PART	1
18	11833	ADAPTER	PART	1
19	92477	SCRW, M4 X 16 SKT FLT HD SS	PART	1
20	12589	WATER DISP LEVER HUB (TRAD)	PART	2
21	92000	SCREW 8 - 32 X 1/8 SS	PART	2
22	92016	SCRW, 10-24 X 3/4 SKT HD FLT PT SS	PART	1
23	91373	BLUE IDENTIFIER	PART	1
24	91374	RED IDENTIFIER	PART	1
25	92192	SCRW, 10-32 X 5/8 SKT HD CUP PT SS	PART	2
26	12583	LEVER HANDLE	PART	2
27	1-431	RED SUPPLY LINE	ASSEMBLY	1
28	1-432	BLUE SUPPLY LINE	ASSEMBLY	1
29	1-433	GREY SUPPLY LINE	ASSEMBLY	1
30	13070	RETAINER PLATE	PART	1
31	13289	NIPPLE	PART	1
32	1-393	1-1/8 18 UNEF MOUNTING KIT	ASSEMBLY	1

ZONE	REV	DESCRIPTION	DATE	APPROVED
-	E	EN-4300jj	04/12/21	R.S.
-	D	EN-3634A	11/21/19	C.G.
-	C	EN-3722	02/08/19	C.G.
-	B	EN-3558a	12/31/18	V.V.
-	A	EN-3240	01/05/17	V.V.
-	-	EN-2980i	10/4/16	J.A.

COPYRIGHT 2005 BRASSTECH, INC. THESE DRAWINGS AND THE DESIGNS DEPICTED HEREIN ARE THE PROPRIETARY PROPERTY OF BRASSTECH. ANY USE OR REPRODUCTION IS SUBJECT TO THE EXPRESS APPROVAL OF BRASSTECH. UNAUTHORIZED USE IS STRICTLY PROHIBITED. ALL RIGHTS RESERVED.

TESTING	-	-	-
ASSEMBLY	-	-	-
PLATING	-	-	-
POLISHING	-	NEXT ASSY	USED ON
MACHINING	-	APPLICATION	
TOOLING FIXTURE #	REMOVE ALL BURRS AND SHARP EDGES		

UNITS ARE: INCHES [MM]
TOLERANCES ARE:
FRACTIONS DECIMALS ANGLES
±1/16" .X ±.1 [2,5] ±1°
.XX ±.06 [1,5]

(X.XXX) DENOTES CRITICAL DIMS.
ALL THREADS ARE CRITICAL

DRAWN	JINSON	04/12/21
CHECKED	R.S.	04/12/21
APPROVED	R.S.	04/12/21

BRASSTECH 2001 CARNEGIE AVE.
INCORPORATED SANTA ANA, CA 92705
(949) 417-5207

**H & C WATER DISP, LEVER
TRAD**

DWG NO. **1030-5603** REV **E**

SCALE .375 REF. - SHEET 1 OF 3

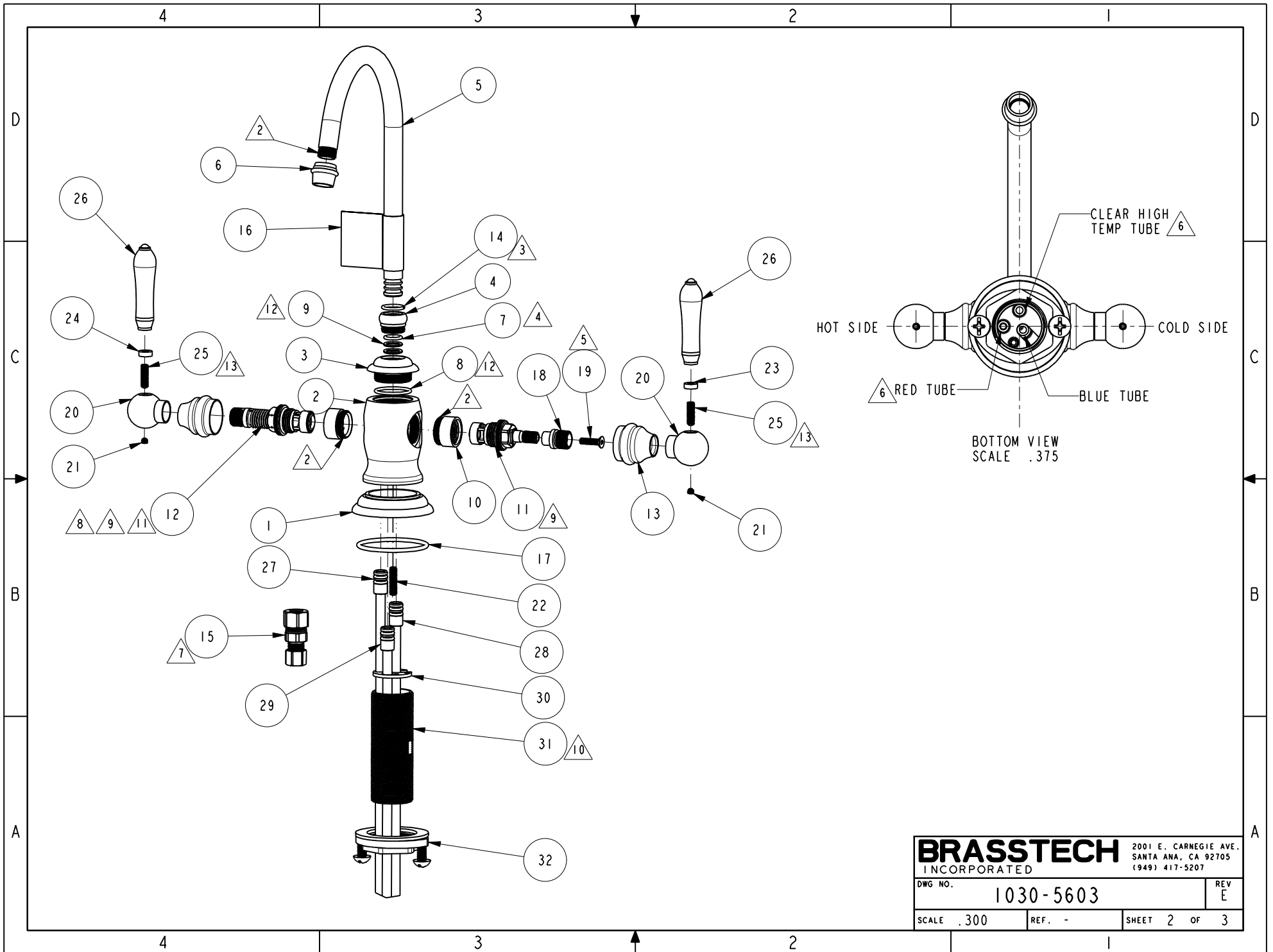

BRASSTECH		2001 E. CARNEGIE AVE. SANTA ANA, CA 92705 (949) 417-5207
DWG NO.	1030-5603	REV E
SCALE .300	REF. -	SHEET 2 OF 3

