

NOTES:

(NI) 1. FIT / FORM / FUNCTION SHALL FOLLOW PS-E.008.

BILL OF MATERIAL (CURRENT LEVEL)

ITEM	PT/ASSY	DESCRIPTION	TYPE	QTY.
1	6XXA	MOUNTING BRACKET	PART	2
2	1-206	HARDWARE PACK	ASSEMBLY	2
3	600A	HEX CONE	PART	2
4	40811	TOWEL BAR POST - RIGHT	PART	1
5	40812	TOWEL BAR POST - LEFT	PART	1
6	91020	O-RING, #2-016, EPDM, 65-75 DURO, NSF 61	PART	2
7	10124	24 IN. TOWEL BAR	PART	1
8	92308	SCRW, M5 X 5 SKT HD CUP PT W/ SELF LOC SS	PART	2
9	10888	HEX KEY, 2.5MM ALLOY STEEL	PART	1

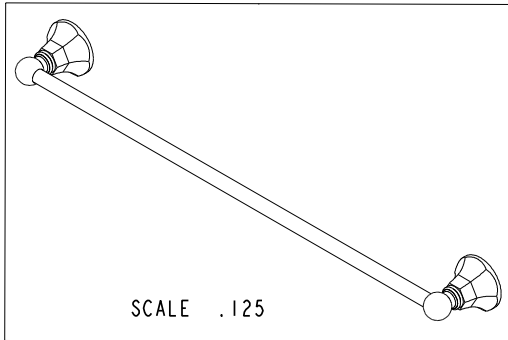
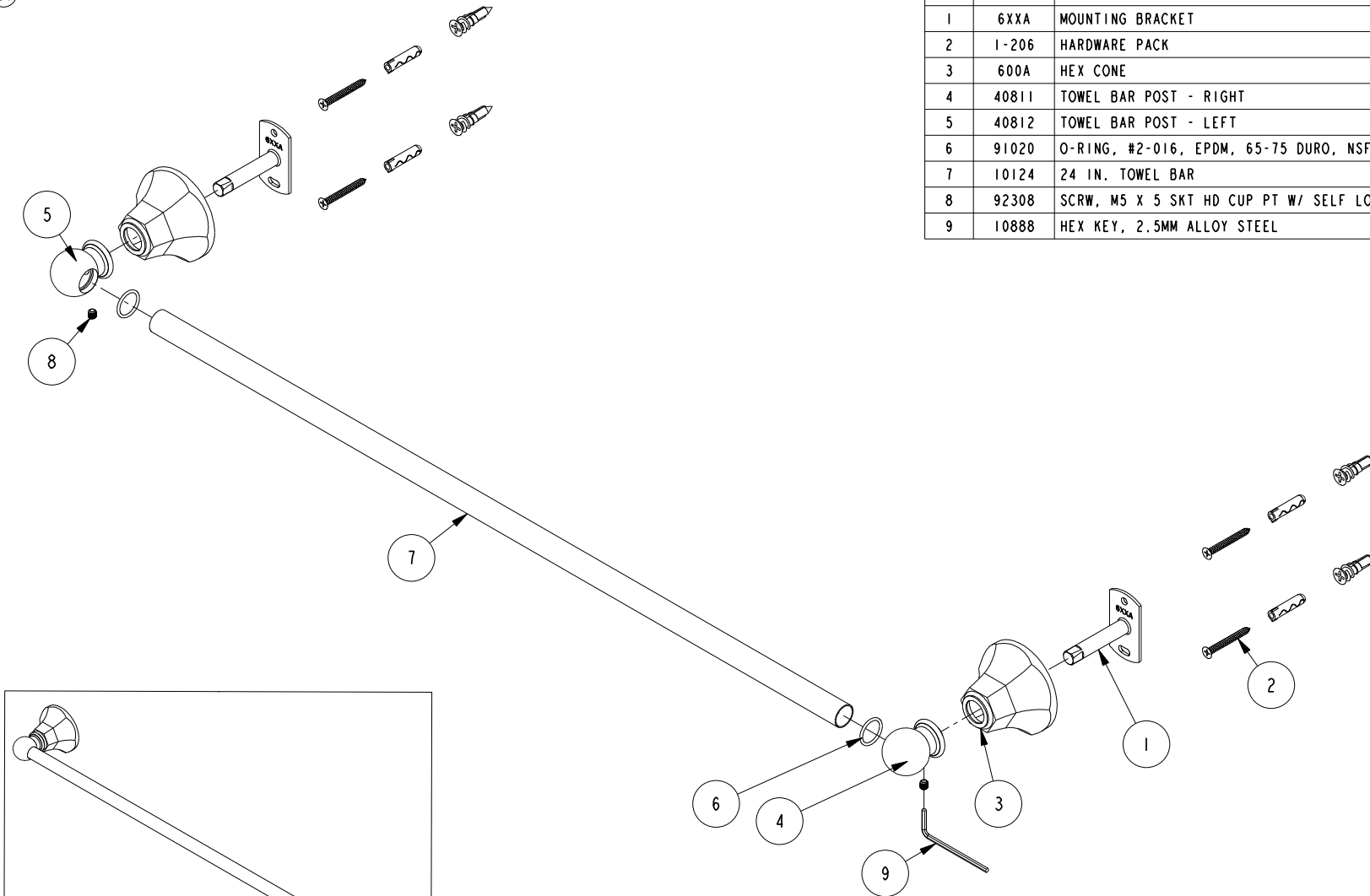

TESTING	-	-	-
ASSEMBLY	-	-	-
PLATING	-	-	-
POLISHING	-	NEXT ASSY	USED ON
MACHINING	-	APPLICATION	
TOOLING FIXTURE #	REMOVE ALL BURRS AND SHARP EDGES		

UNITS ARE: INCHES [MM]			
TOLERANCES ARE:			
FRACTIONS	DECIMALS	ANGLES	
±1/16"	.X ±.1 [2,5]	±1°	
	.XX ±.06 [1,5]		
(X.XXX) DENOTES CRITICAL DIMS.			
ALL THREADS ARE CRITICAL			
DRAWN	R.S.	08/15/19	
CHECKED	J.M.	08/15/19	
APPROVED	J.M.	08/15/19	

BRASSTECH 2001 CARNEGIE AVE.
INCORPORATED SANTA ANA, CA 92705
(949) 417-5207

24" TOWEL BAR

DWG NO.	1200-1250	REV	-
SCALE	.250	REF.	-
SHEET	1	OF	2

COPYRIGHT 2005 BRASSTECH, INC.
THESE DRAWINGS AND THE DESIGNS
DEPICTED HEREIN ARE THE PROPRIETARY
PROPERTY OF BRASSTECH. ANY USE
OR REPRODUCTION IS SUBJECT TO
THE EXPRESS APPROVAL OF BRASSTECH.
UNAUTHORIZED USE IS STRICTLY
PROHIBITED. ALL RIGHTS RESERVED.

EN-3913	08/15/19	J.M.
ZONE	REV	DESCRIPTION
DATE	APPROVED	

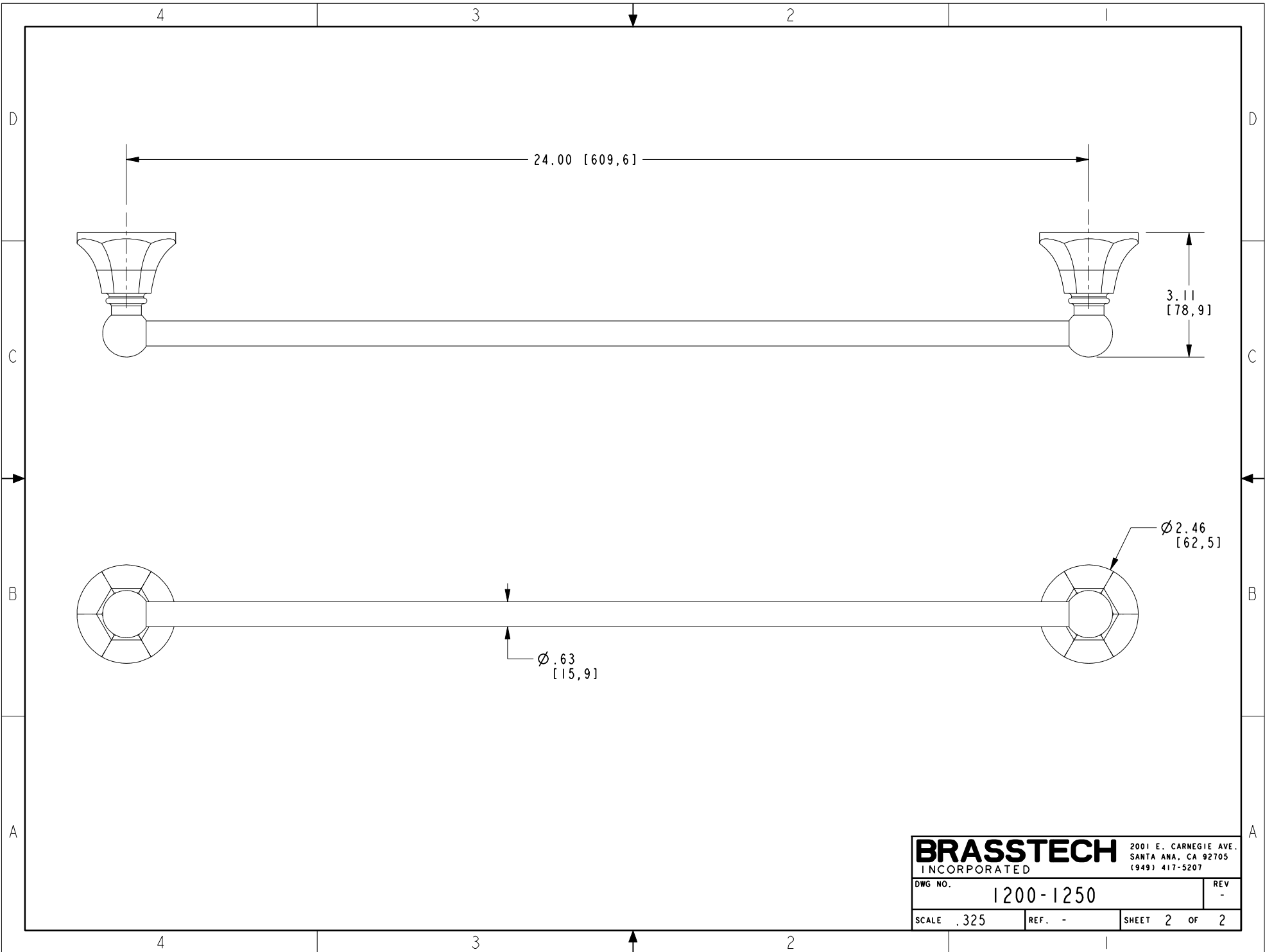

BRASSTECH		2001 E. CARNEGIE AVE. SANTA ANA, CA 92705 (949) 417-5207
DWG NO.	1200-1250	REV -
SCALE .325	REF. -	SHEET 2 OF 2