

REPLACEMENT PARTS

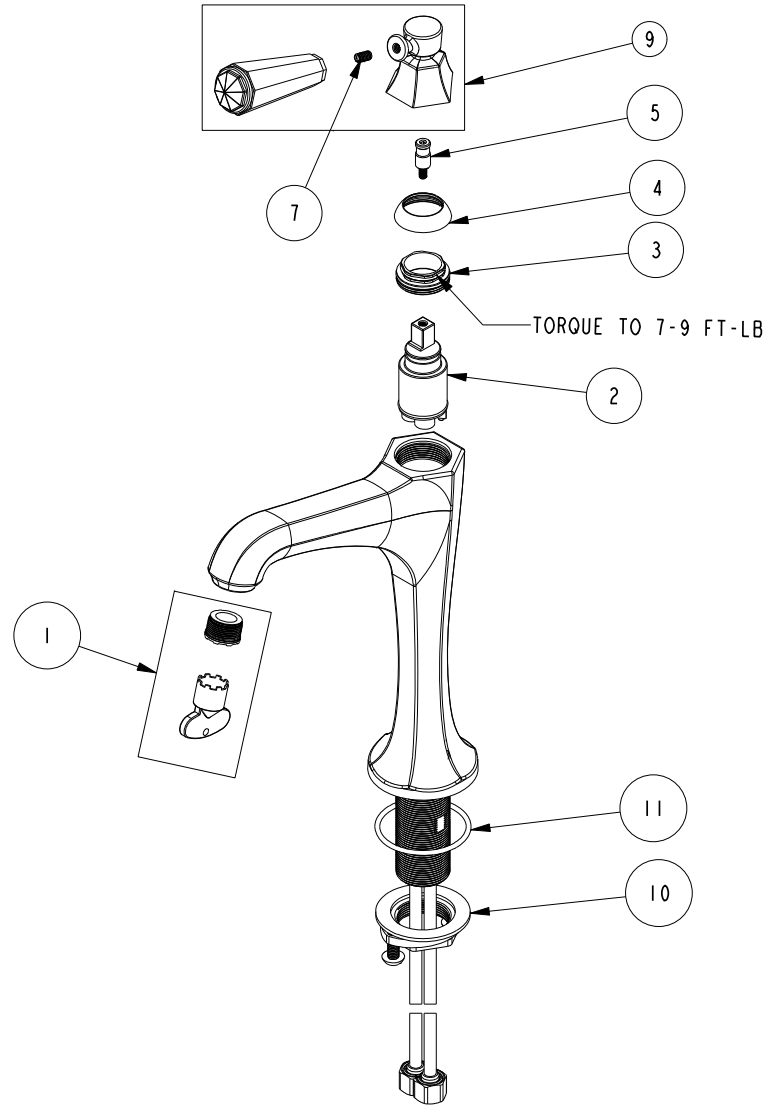

ITEM	PT/ASSY	SPECIFY FINISH	DESCRIPTION
1	1-492		AERATOR 1.2 GPM WITH KEY
2	1-259		MIXING VALVE - FX25
3	1-275		CARTRIDGE RETAINER ASSEMBLY
4	12034	YES	DECORATIVE CAP
5	12005		STEM ADAPTOR
7	92025		SCRW, 10-24 X 3/8 SKT HD CUP PT SS
9	20-720	YES	LEVER HANDLE ASM
10	1-393		1-1/8 18 UNEF MOUNTING KIT
11	91773		O-RING, #2-133, 50 DURO

Vessel Sink / Bar Faucet
1233-1

REV J EN-4816-1 06/19/24

NEWPORT BRASS.

t: 949.417.5207 | www.newportbrass.com