

NOTES:

1. TO INSPECT ASSEMBLY, FOLLOW FIRST ARTICLE AND IN PROCESS INSPECTION SHEET.

- 2 APPLY LOCTITE 242.
- 3 APPLY LOCTITE 680
- 4 TORQUE 15-20 IN-LB
- 5 WRAP AROUND SHANK

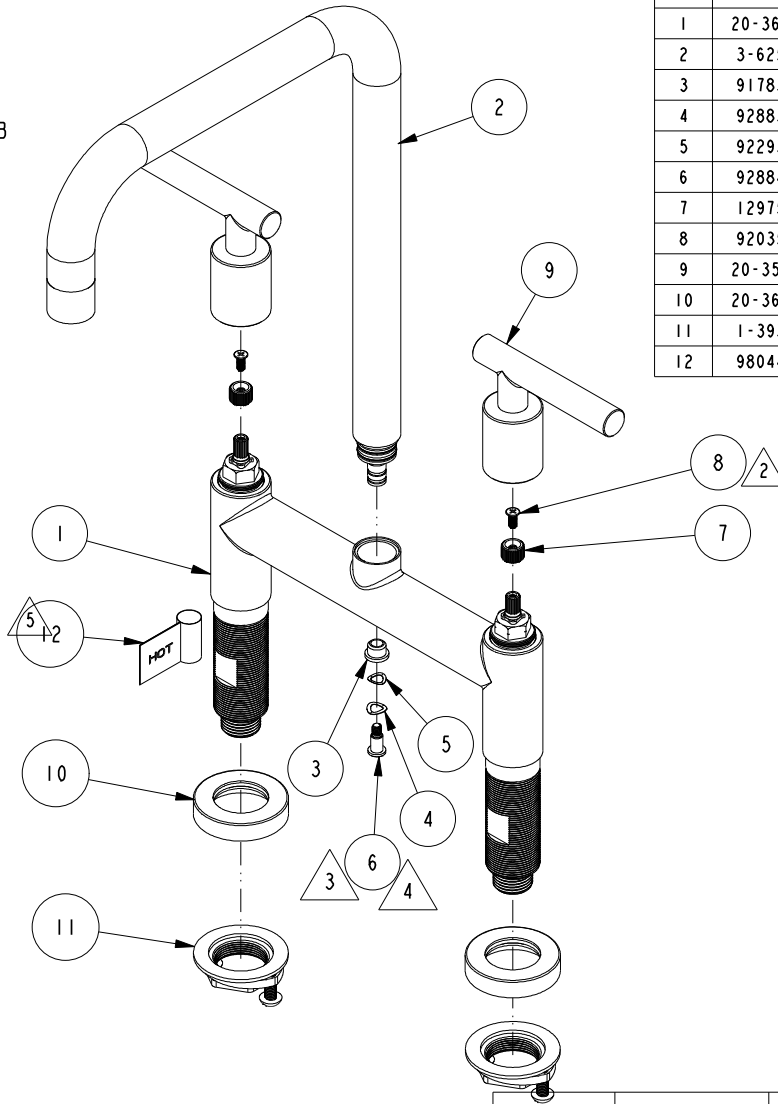

BILL OF MATERIAL (CURRENT LEVEL)

ITEM	PT/ASSY	DESCRIPTION	TYPE	QTY.
1	20-369	KITCHEN BRIDGE BODY ASM	ASSEMBLY	1
2	3-625	SPOUT ASSEMBLY	ASSEMBLY	1
3	91783	FLANGED SLEEVE BEARING	PART	1
4	92883	WSHR, .27 ID X .42 OD X .008 THK, WAVE, SPRING STEEL	PART	1
5	92293	WSHR, .24 ID X .39 OD X .01 THK, WAVE, SPRING STEEL	PART	1
6	92884	SCRW, 10-32 X 3/8 SKT CAP LOW HD SS	PART	1
7	12975	ADAPTER	PART	2
8	92035	SCRW, M4 X .7 X 10 PHL FLT HD SS	PART	2
9	20-352	LEVER HANDLE ASM	ASSEMBLY	2
10	20-368	ESCUTCHEON ASM	ASSEMBLY	2
11	1-393	1-1/8 18 UNEF MOUNTING KIT	ASSEMBLY	2
12	98044	LABEL - HOT	PART	1

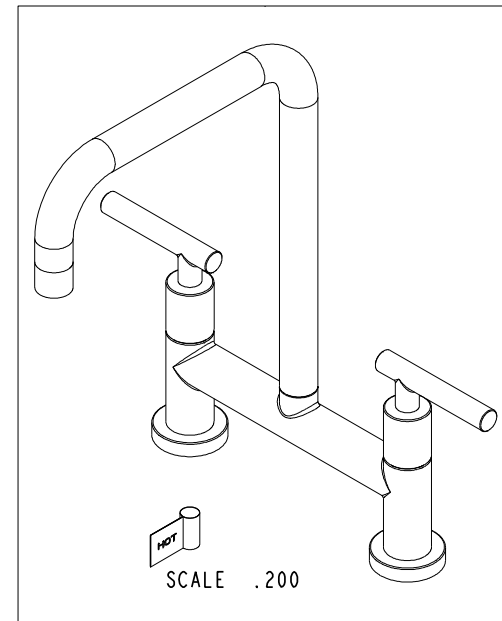

ZONE	REV	DESCRIPTION	DATE	APPROVED
-	C	EN-4300f	02/24/21	R. S.
-	B	EN-3866	05/17/19	J. M.
-	A	EN-3818	02/25/19	J. M.
-	-	EN-3364	09/24/18	J. M.

COPYRIGHT 2005 BRASSTECH, INC. THESE DRAWINGS AND THE DESIGNS DEPICTED HEREIN ARE THE PROPRIETARY PROPERTY OF BRASSTECH. ANY USE OR REPRODUCTION IS SUBJECT TO THE EXPRESS APPROVAL OF BRASSTECH. UNAUTHORIZED USE IS STRICTLY PROHIBITED. ALL RIGHTS RESERVED.

TESTING	-	-	-
ASSEMBLY	-	-	-
PLATING	-	-	-
POLISHING	-	NEXT ASSY	USED ON
MACHINING	-	APPLICATION	
TOOLING FIXTURE #	REMOVE ALL BURRS AND SHARP EDGES		

UNITS ARE: INCHES [MM]
 TOLERANCES ARE:
 FRACTIONS DECIMALS ANGLES
 ±1/16" .X ±.1 [2.5]
 .XX ±.06 [1.5] ±1°

(X.XXX) DENOTES CRITICAL DIMS.
 ALL THREADS ARE CRITICAL

DRAWN	JIMSON	09/24/18
CHECKED	J. M.	09/24/18
APPROVED	J. M.	09/24/18

BRASSTECH 2001 CARNEGIE AVE.
 INCORPORATED SANTA ANA, CA 92705
 (949) 417-5207

KITCHEN BRIDGE FAUCET

DWG NO.	1400-5403	REV	C
SCALE	.250	REF.	-
SHEET	1	OF	2

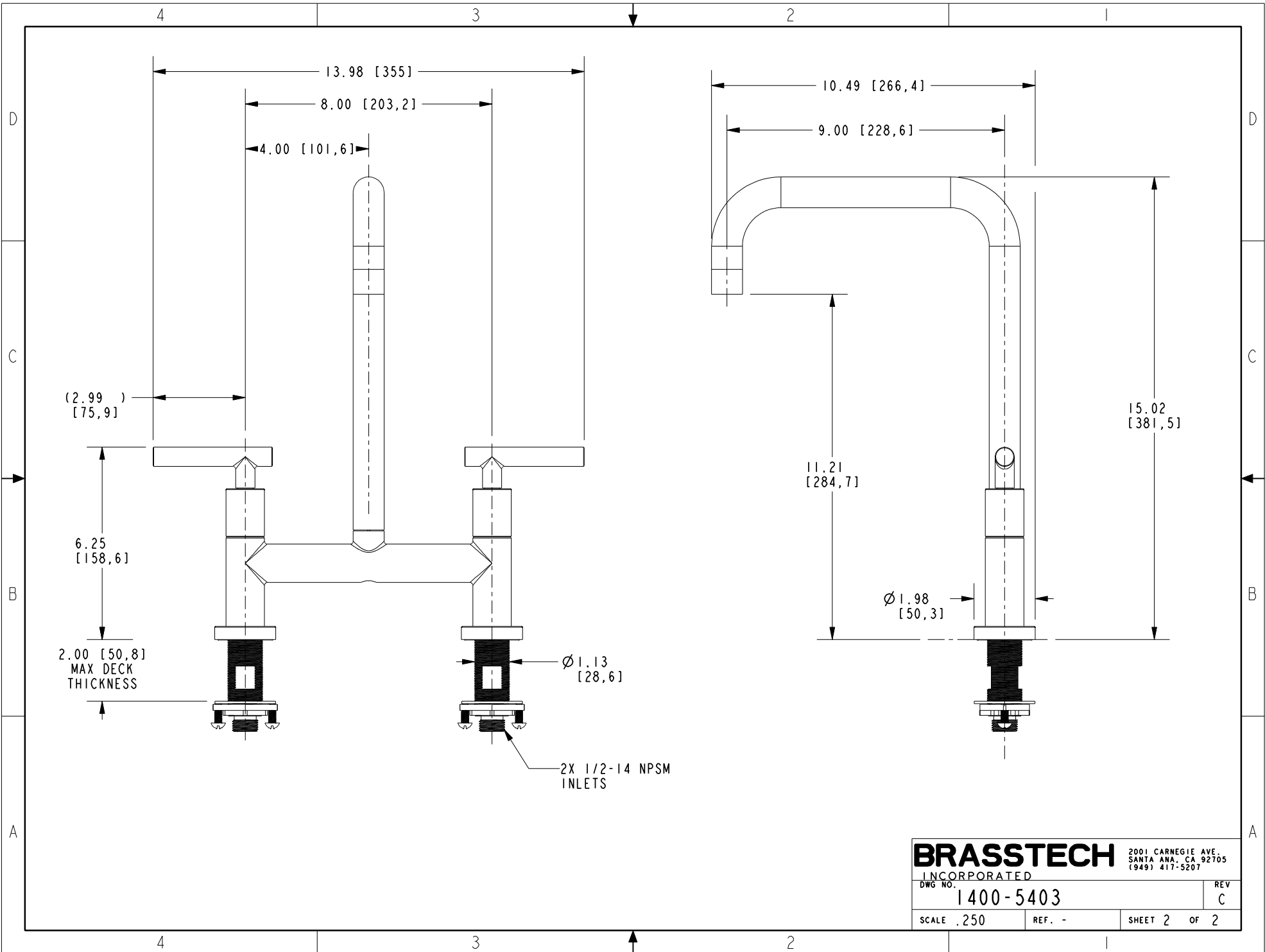

BRASSTECH 2001 CARNEGIE AVE.
INCORPORATED SANTA ANA, CA 92705
(949) 417-5207

DWG NO.	1400-5403	REV	C
SCALE	.250	REF.	-
SHEET 2		OF 2	