

4

3

2

1

NOTES:

1. TO INSPECT ASSEMBLY, FOLLOW FIRST ARTICLE AND IN PROCESS INSPECTION SHEET.

2. PUT THESE ITEMS IN SEPARATE PLASTIC BAGS.

3. INSTALLATION TORQUE: 78 LB-IN +/- 6 LB-IN

4. APPLY THIN COAT OF SILICON GREASE FOR ALL O-RINGS BEFORE INSTALLATION.

5. APPLY LOCTITE 242, IF SCREW DOES NOT HAVE NYLON PATCH.

6. APPLY LOCTITE 680.

7. TORQUE SWIVEL NUT TO 19 +/-2 LB-IN.

8. TORQUE TO 10 +/-2 LB-FT.

9. PARTIALLY THREAD MOUNTING KIT ONTO SHANK

10. DO NOT DOCK SPRAY HEAD TO SPOUT WHEN PACKAGING.

11. PLACE 2.5" INCHES FROM END OF HOSE

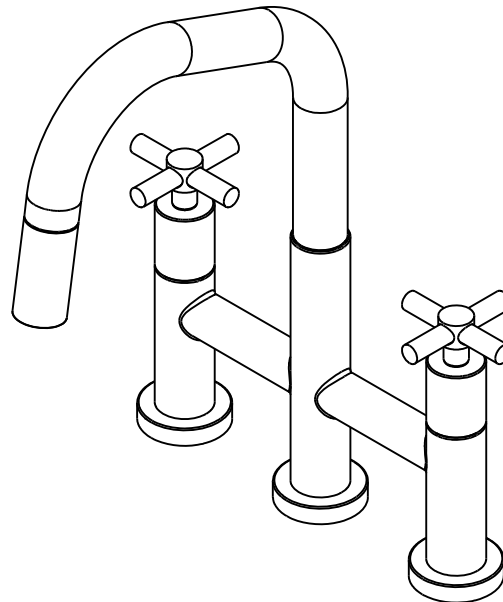

BILL OF MATERIAL (CURRENT LEVEL)

| ITEM | PT/ASSY | DESCRIPTION | TYPE | QTY. |
|------|---------|---|----------|------|
| 1 | 13656 | BRIDGE PULLDOWN BODY | PART | 1 |
| 2 | 1-471 | 5/16" PEX COLD SUPPLY | ASSEMBLY | 1 |
| 3 | 1-472 | 5/16" PEX HOT SUPPLY | ASSEMBLY | 1 |
| 4 | 1-473 | 5/16" PEX HOSE | ASSEMBLY | 2 |
| 5 | 92929 | RETAINING PLATE | PART | 2 |
| 6 | 92527 | SCRW, 8-32 X 3/8 SKT CAP HD SS | PART | 4 |
| 7 | 20-368 | ESCUTCHEON ASM | ASSEMBLY | 3 |
| 8 | 13289 | NIPPLE | PART | 3 |
| 9 | 1-005 | C/S VALVE CARTRIDGE - COLD | PART | 1 |
| 10 | 1-006 | C/S VALVE CARTRIDGE - HOT | PART | 1 |
| 11 | 12975 | ADAPTER | PART | 2 |
| 12 | 92035 | SCRW, M4 X .7 X 10 PHL FLT HD SS | PART | 2 |
| 13 | 20-354 | CROSS HANDLE ASM | ASSEMBLY | 2 |
| 14 | 12751 | SPOUT ADAPTER | PART | 1 |
| 15 | 91030 | O-RING, #2- 115, EPDM, 65-75 DURO, NSF 61 | PART | 4 |
| 16 | 91712 | SLEEVE | PART | 1 |
| 17 | 13113 | PULLDOWN SPOUT | PART | 1 |
| 18 | 91544 | MAGNET DOCKING | ASSEMBLY | 1 |
| 19 | 11877A | HOSE, PULLDOWN, GREY | ASSEMBLY | 1 |
| 20 | 3-480 | SPRAY HEAD, EAST LINEAR | ASSEMBLY | 1 |
| 21 | 1-393 | 1-1/8 18 UNEF MOUNTING KIT | ASSEMBLY | 3 |
| 22 | 92934 | 5/16" TUBE TEE CONNECTOR | PART | 1 |
| 23 | 1-474 | PEX PULLDOWN CONNECTOR | ASSEMBLY | 1 |
| 24 | 98044 | LABEL - HOT | PART | 2 |
| 25 | 91568 | RETAINER CLIP | PART | 1 |
| 26 | 1-286A | WEIGHT | ASSEMBLY | 1 |

| | | | |
|-------------------|---|----------------------------------|---------|
| TESTING | - | - | - |
| ASSEMBLY | - | - | - |
| PLATING | - | - | - |
| POLISHING | - | NEXT ASSY | USED ON |
| MACHINING | - | APPLICATION | |
| TOOLING FIXTURE # | | REMOVE ALL BURRS AND SHARP EDGES | |

UNITS ARE: INCHES [MM]
TOLERANCES ARE:
FRACTIONS DECIMALS ANGLES
±1/16" .X ±.1 [2.5] ±1°
.XX ±.06 [1.5]

(X.XXX) DENOTES CRITICAL DIMS.
ALL THREADS ARE CRITICAL

DRAWN G.B. 02/02/21
CHECKED J.M. 02/02/21
APPROVED J.M. 02/02/21

BRASSTECH
INCORPORATED

2001 CARNEGIE AVE.
SANTA ANA, CA 92705
(949) 417-5207

BRIDGE PULLDOWN

DWG NO.

1400-5462

REV

-

SCALE .250

REF. -

SHEET 1 OF 3

COPYRIGHT 2005 BRASSTECH, INC.
THESE DRAWINGS AND THE DESIGNS
DEPICTED HEREIN ARE THE PROPRIETARY
PROPERTY OF BRASSTECH. ANY USE
OR REPRODUCTION IS SUBJECT TO
THE EXPRESS APPROVAL OF BRASSTECH.
UNAUTHORIZED USE IS STRICTLY
PROHIBITED. ALL RIGHTS RESERVED.

| ZONE | REV | DESCRIPTION | DATE | APPROVED |
|------|-----|-------------|----------|----------|
| - | - | EN-4307 | 02/02/21 | J.M. |

4

3

2

1

D

D

C











C

B

B

A

A

-  PUT THESE ITEMS IN SEPARATE PLASTIC BAGS.
-  INSTALLATION TORQUE: 78 LB-IN +/- 6 LB-IN
-  APPLY THIN COAT OF SILICON GREASE FOR ALL O-RINGS BEFORE INSTALLATION.
-  APPLY LOCTITE 242, IF SCREW DOES NOT HAVE NYLON PATCH.
-  APPLY LOCTITE 680.
-  TORQUE SWIVEL NUT TO 19 +/- 2 LB-IN.
-  TORQUE TO 10 +/- 2 LB-FT.
-  PARTIALLY THREAD MOUNTING KIT ONTO SHANK
-  DO NOT DOCK SPRAY HEAD TO SPOUT WHEN PACKAGING.
-  PLACE 2.5" INCHES FROM END OF HOSE

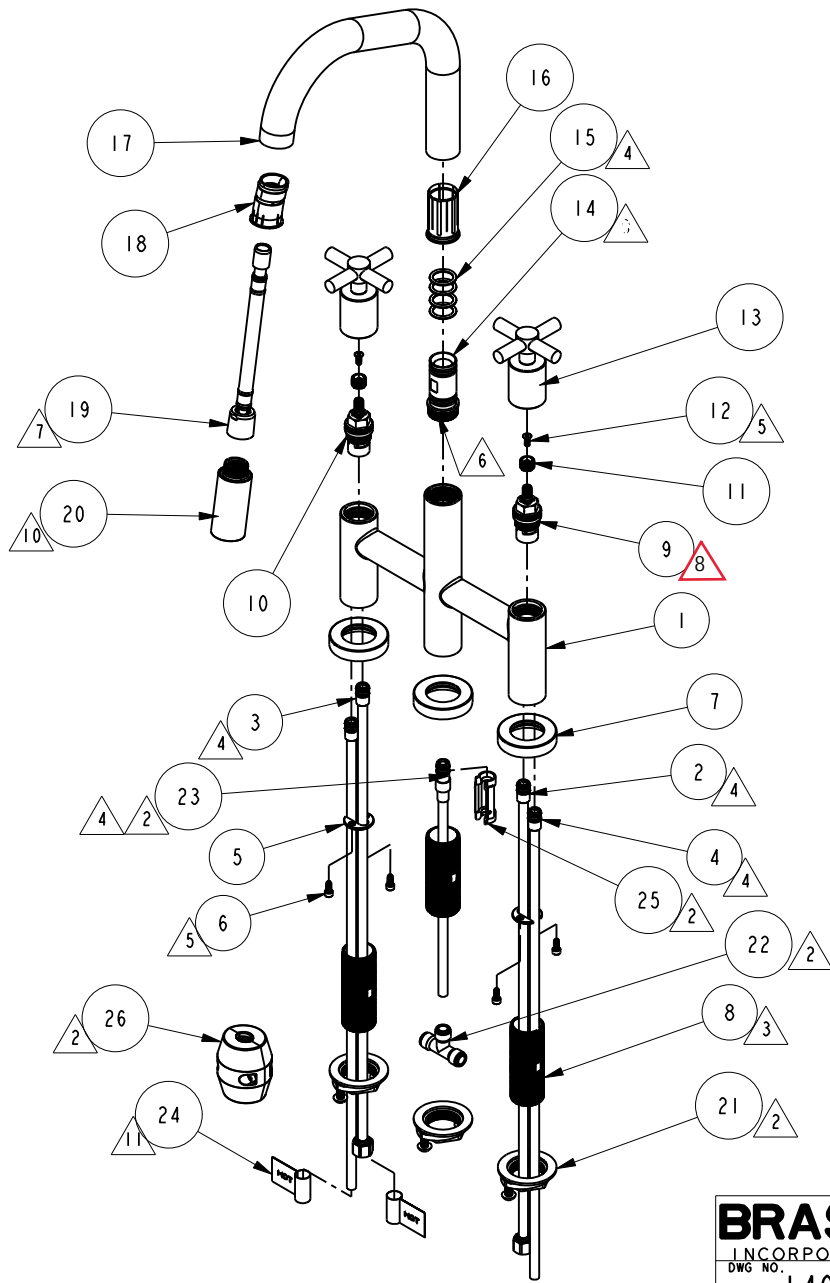

| | | | |
|------------------|-----------|---|---|
| BRASSTECH | | 2001 CARNEGIE AVE. SANTA ANA, CA 92705 (949) 417-5207 | |
| INCORPORATED | | | |
| DWG NO. | 1400-5462 | REV | - |
| SCALE | .155 | REF. | - |
| | | SHEET 2 OF 3 | |

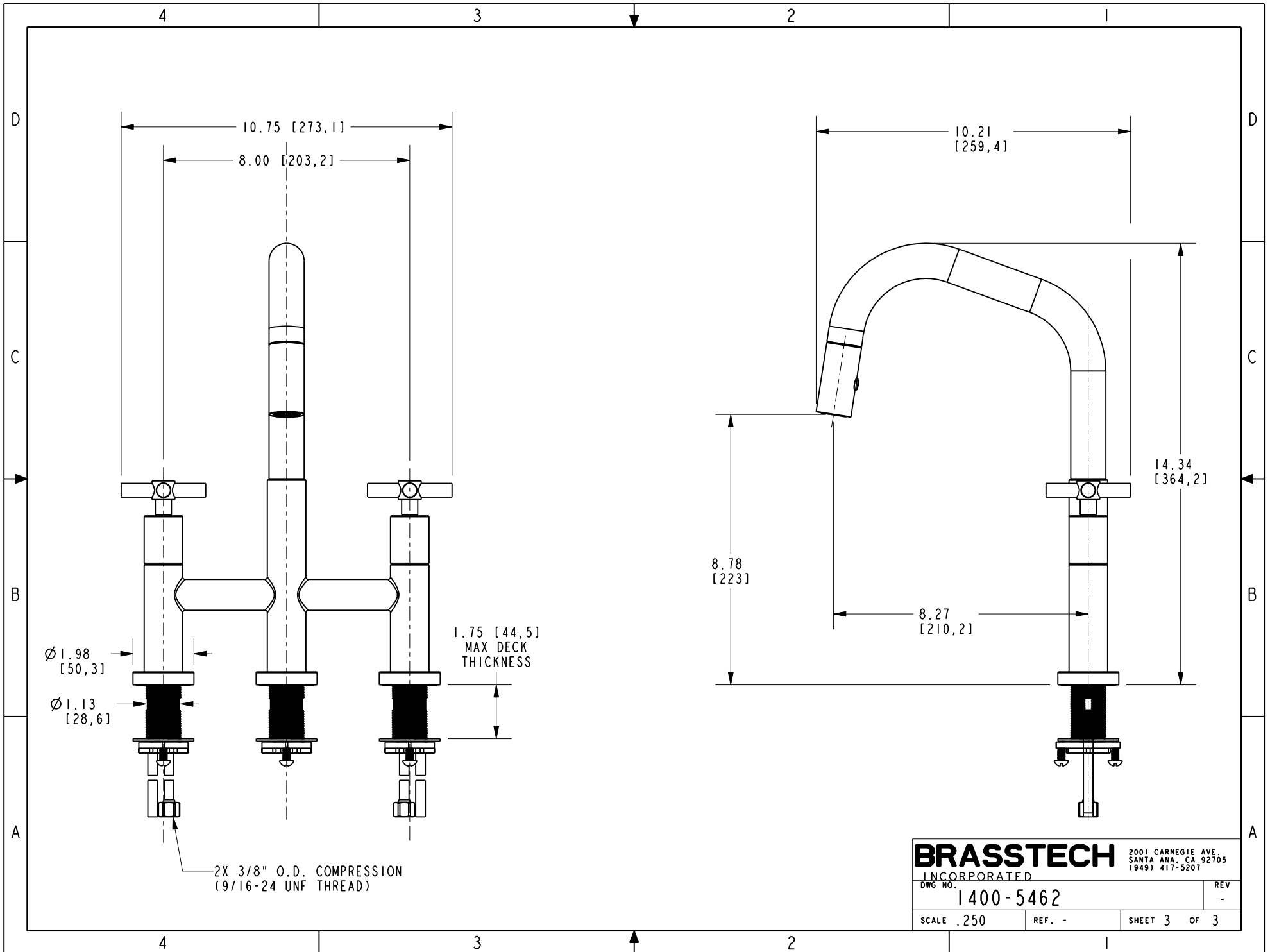

BRASSTECH 2001 CARNEGIE AVE.
 INCORPORATED SANTA ANA, CA 92705
 (949) 417-5207

| | | | |
|---------|-----------|------|---|
| DWG NO. | 1400-5462 | REV | - |
| SCALE | .250 | REF. | - |
| SHEET 3 | | OF 3 | |