

REPLACEMENT PARTS

NOTE:

1 USE SILICON GREASE (PART NUMBER 6727) TO LUBRICATE O-RINGS BEFORE INSTALL.

ITEM	PT/ASSY	SPECIFY FINISH	DESCRIPTION
1	1-064		SINGLE LEVER CARTRIDGE
2	2-781		CART. RETAINER ASM
3	91227		O-RING, #2-125 EPDM
4	12823	YES	HANDLE HUB
5	91534		CARTRIDGE STEM INSERT
6	1-519		HANDLE ADAPTER SCREW WITH HEX KEY
7	10159		HEX KEY, 3/32 ALLOY STEEL
8	20-313	YES	HANDLE LEVER ASM
9	92001		SCRW, 8-32 X 3/16 SKT HD FLT PT SS
10	10192		HEX KEY TOOL, #8 5/64
11	11877		HOSE, PULLDOWN SWIVEL
12	3-416	YES	SPRAY HEAD, CONTEMP
13	1-399		O-RING KIT FOR SPOUT PEX CONECTION
14	1-256		MOUNTING KIT
15	91568		RETAINER CLIP
16	1-286		WEIGHT ASM
17	91139		WASHER RBR 1-3/8

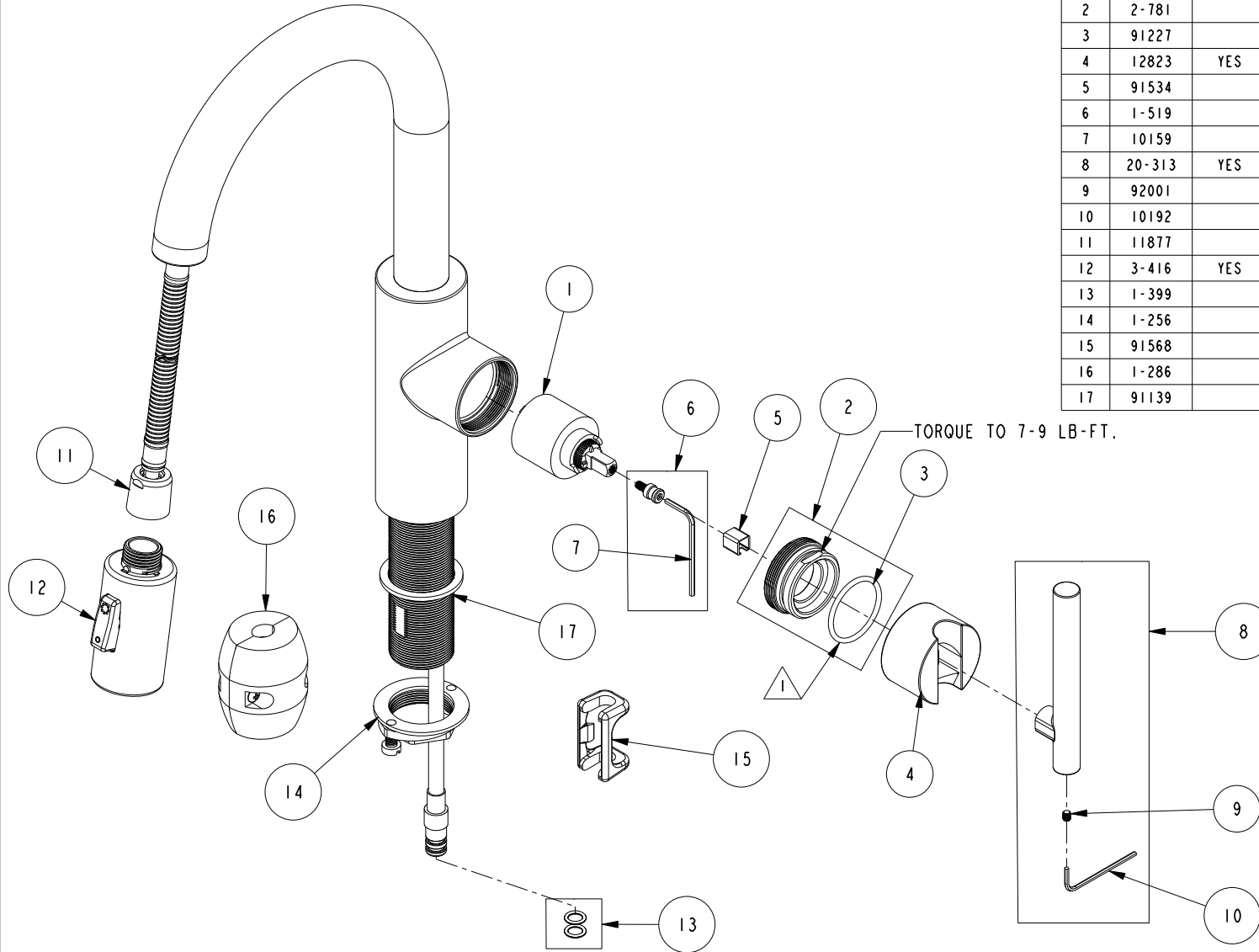

EAST LINEAR PULL DOWN - BAR/PERP FAUCET
1500-5203

NEWPORT BRASS.

t: 949.417.5207 | www.newportbrass.com