

NOTES:

1. TO INSPECT ASSEMBLY, FOLLOW FIRST ARTICLE AND IN PROCESS INSPECTION SHEET.

BILL OF MATERIAL (CURRENT LEVEL)

ITEM	PT/ASSY	DESCRIPTION	TYPE	QTY.
1	20-156	AIR SWITCH, COMTEMP	ASSEMBLY	1
2	91321	TUBING - PVC BLK (6ft)	PART	1
3	50648	ELECTRIC PLUG SWITCH	PART	1

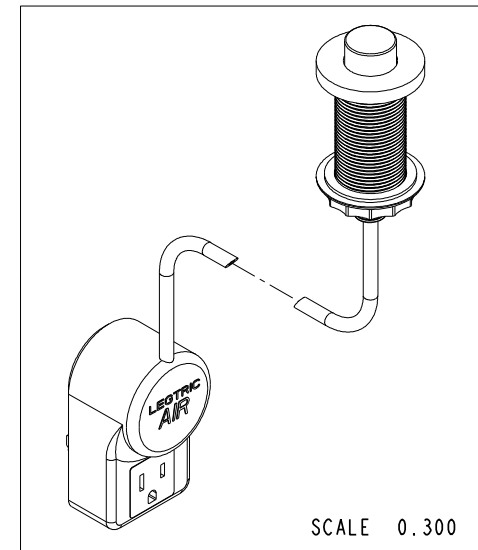
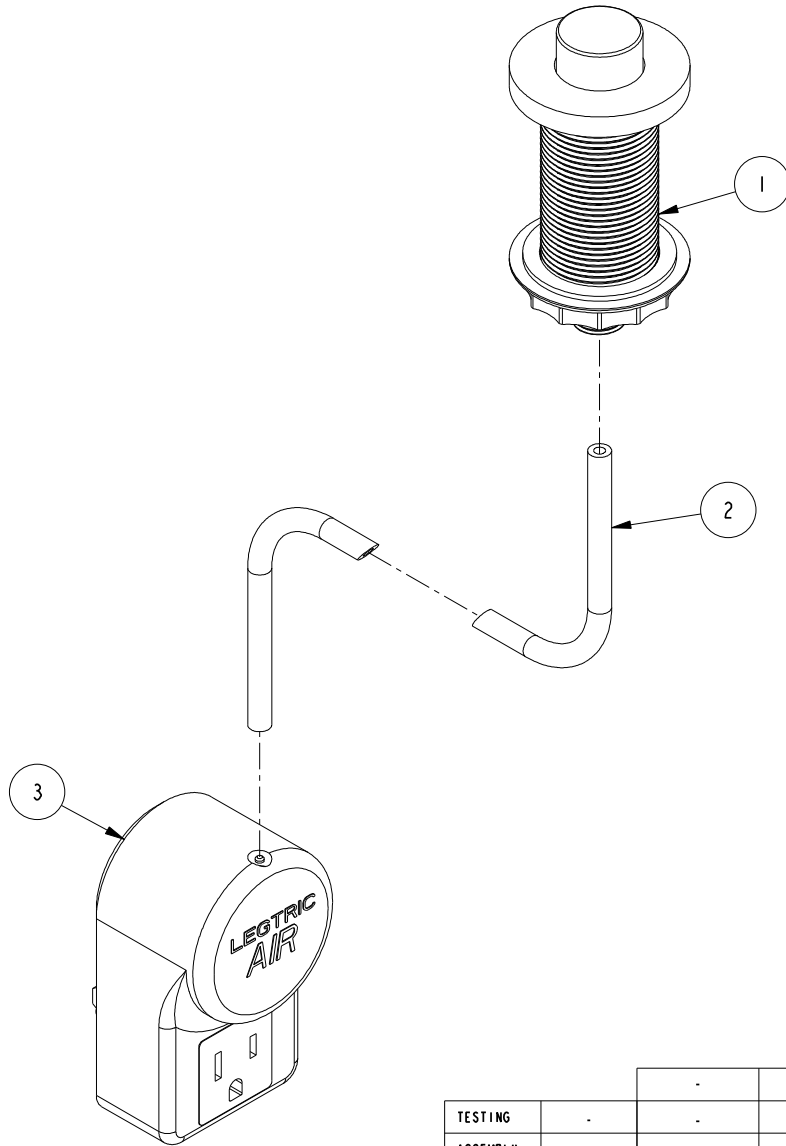

TESTING	-	-	-
ASSEMBLY	-	-	-
PLATING	-	-	-
POLISHING	-	NEXT ASSY	USED ON
MACHINING	-	APPLICATION	
TOOLING FIXTURE #	REMOVE ALL BURRS AND SHARP EDGES		

UNITS ARE: INCHES [MM]
 TOLERANCES ARE:
 FRACTIONS DECIMALS ANGLES
 $\pm 1/16"$.X $\pm .1$ [2.5] $\pm 1^\circ$
 .XX $\pm .06$ [1.5]

(X.XXX) DENOTES CRITICAL DIMS.
 ALL THREADS ARE CRITICAL

DRAWN	AN	04/29/16
CHECKED	AN	04/29/16
APPROVED	AN	04/29/16

BRASSTECH
 INCORPORATED

2001 CARNEGIE AVE.
 SANTA ANA, CA 92705
 (949) 417-5207

**AIR ACTV ELECTRIC SWITCH,
 CONTEMP**

DWG NO.	1500-5811	REV	B
SCALE	0.500	REF.	SHEET 1 OF 2

-	B	EN-4300r	09/24/21	R.S.
-	A	EN-3368o	12/28/17	JM
-	-	EN-3016	04/29/16	AN
ZONE	REV	DESCRIPTION	DATE	APPROVED

COPYRIGHT 2005 BRASSTECH, INC.
 THESE DRAWINGS AND THE DESIGNS
 DEPICTED HEREIN ARE THE PROPRIETARY
 PROPERTY OF BRASSTECH. ANY USE
 OR REPRODUCTION IS SUBJECT TO
 THE EXPRESS APPROVAL OF BRASSTECH.
 UNAUTHORIZED USE IS STRICTLY
 PROHIBITED. ALL RIGHTS RESERVED.

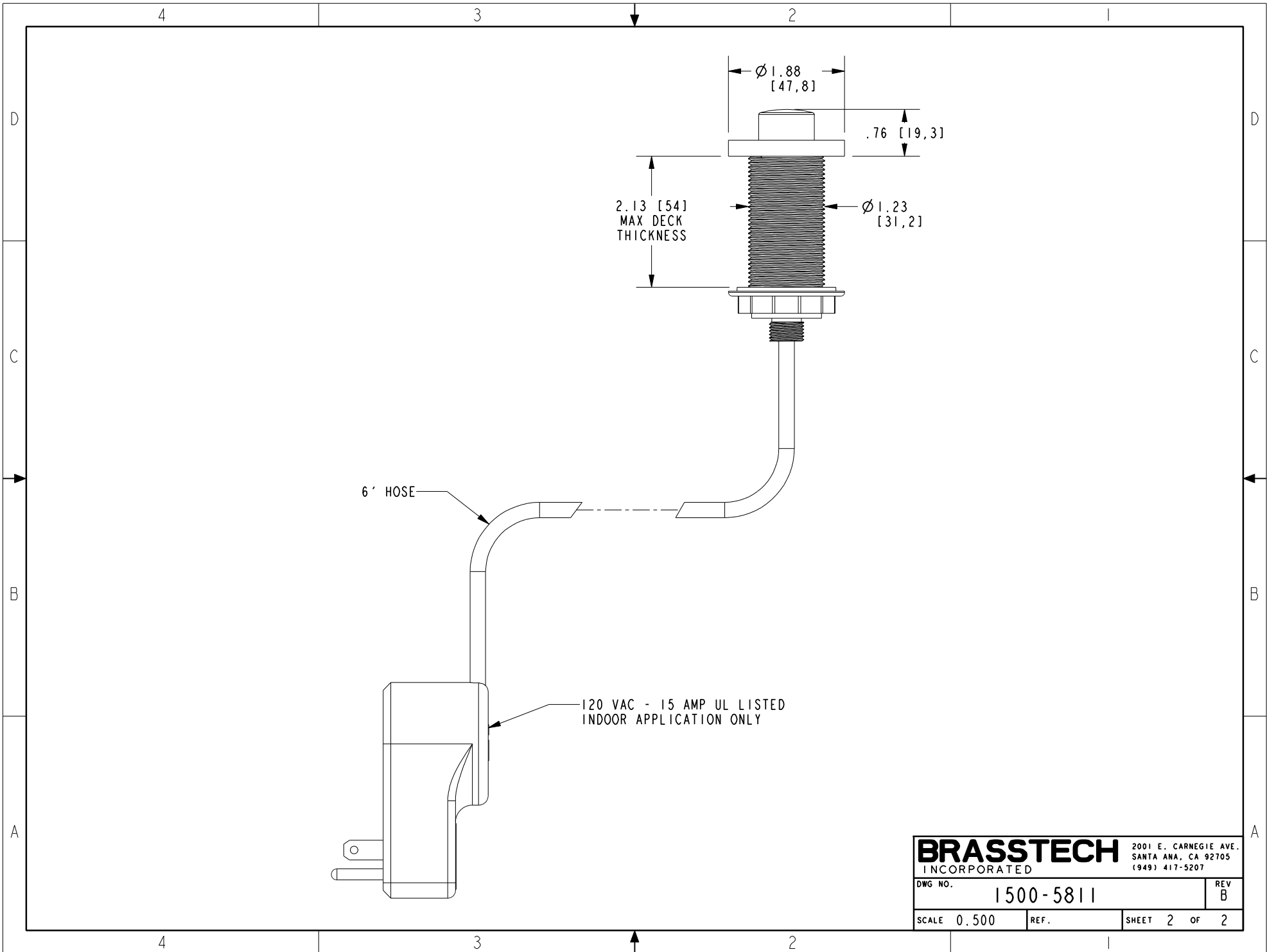

BRASSTECH		2001 E. CARNEGIE AVE. SANTA ANA, CA 92705 (949) 417-5207	
DWG NO.	1500-5811	REV	B
SCALE	0.500	REF.	SHEET 2 OF 2