

NOTES:

1. TO INSPECT ASSEMBLY, FOLLOW FIRST ARTICLE AND IN PROCESS INSPECTION SHEET.

**BILL OF MATERIAL (CURRENT LEVEL)**

ITEM	PT/ASSY	DESCRIPTION	TYPE	QTY.
1	2-159	POP-UP ROD GUIDE ASSEMBLY	ASSEMBLY	1
2	2-235	BIDET DIVERTER / V. BRE	ASSEMBLY	1
3	2-236	DOUCHE SPRAY ASSEMBLY	ASSEMBLY	1
4	325	POP UP ASSEMBLY	ASSEMBLY	1
5	3-255	TRIM KIT - HANDLE / ES	ASSEMBLY	2
6	10827	POP-UP KNOB	PART	1
7	10288	3/16" POP UP ROD	PART	1
8	1-542	VALVE KIT - BIDET	ASSEMBLY	1

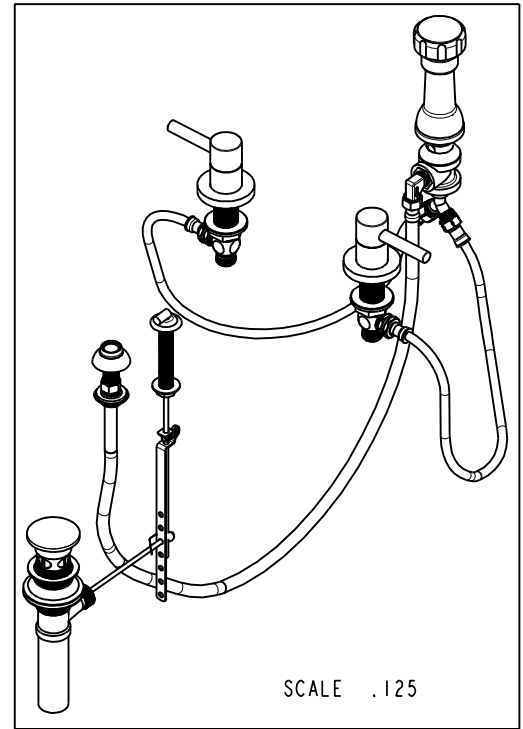
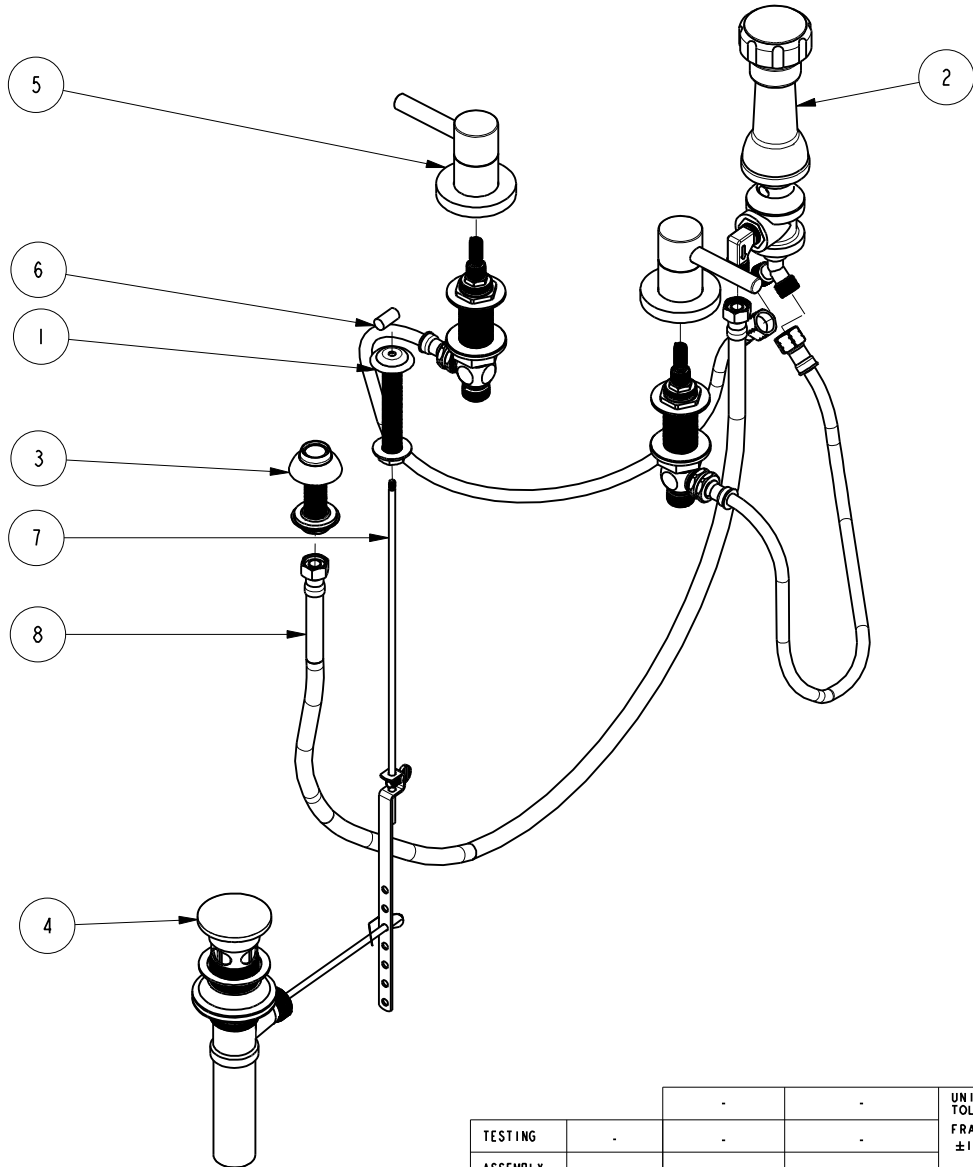

ZONE	REV	DESCRIPTION	DATE	APPROVED
-	A	EN-4300c	01/08/21	R.S.
-	-	RELEASED	08/14/02	-

COPYRIGHT 2005 BRASSTECH, INC. THESE DRAWINGS AND THE DESIGNS DEPICTED HEREIN ARE THE PROPRIETARY PROPERTY OF BRASSTECH. ANY USE OR REPRODUCTION IS SUBJECT TO THE EXPRESS APPROVAL OF BRASSTECH. UNAUTHORIZED USE IS STRICTLY PROHIBITED. ALL RIGHTS RESERVED.

TESTING	-	-	-
ASSEMBLY	-	-	-
PLATING	-	-	-
POLISHING	-	NEXT ASSY	USED ON
MACHINING	-	APPLICATION	
TOOLING FIXTURE #	REMOVE ALL BURRS AND SHARP EDGES		

UNITS ARE: INCHES [MM]		
TOLERANCES ARE:		
FRACTIONS	DECIMALS	ANGLES
±1/16"	.X ±.1 [2,5]	±°
	.XX ±.06 [1,5]	
(X.XXX) DENOTES CRITICAL DIMS.		
ALL THREADS ARE CRITICAL		
DRAWN	JINSON	01/08/21
CHECKED	R.S.	01/08/21
APPROVED	R.S.	01/08/21

**BRASSTECH** 2001 CARNEGIE AVE.  
INCORPORATED SANTA ANA, CA 92705  
(949) 417-5207

**BIDET SET**

DWG NO. **1509** REV **A**

SCALE .175 REF. - SHEET 1 OF 2

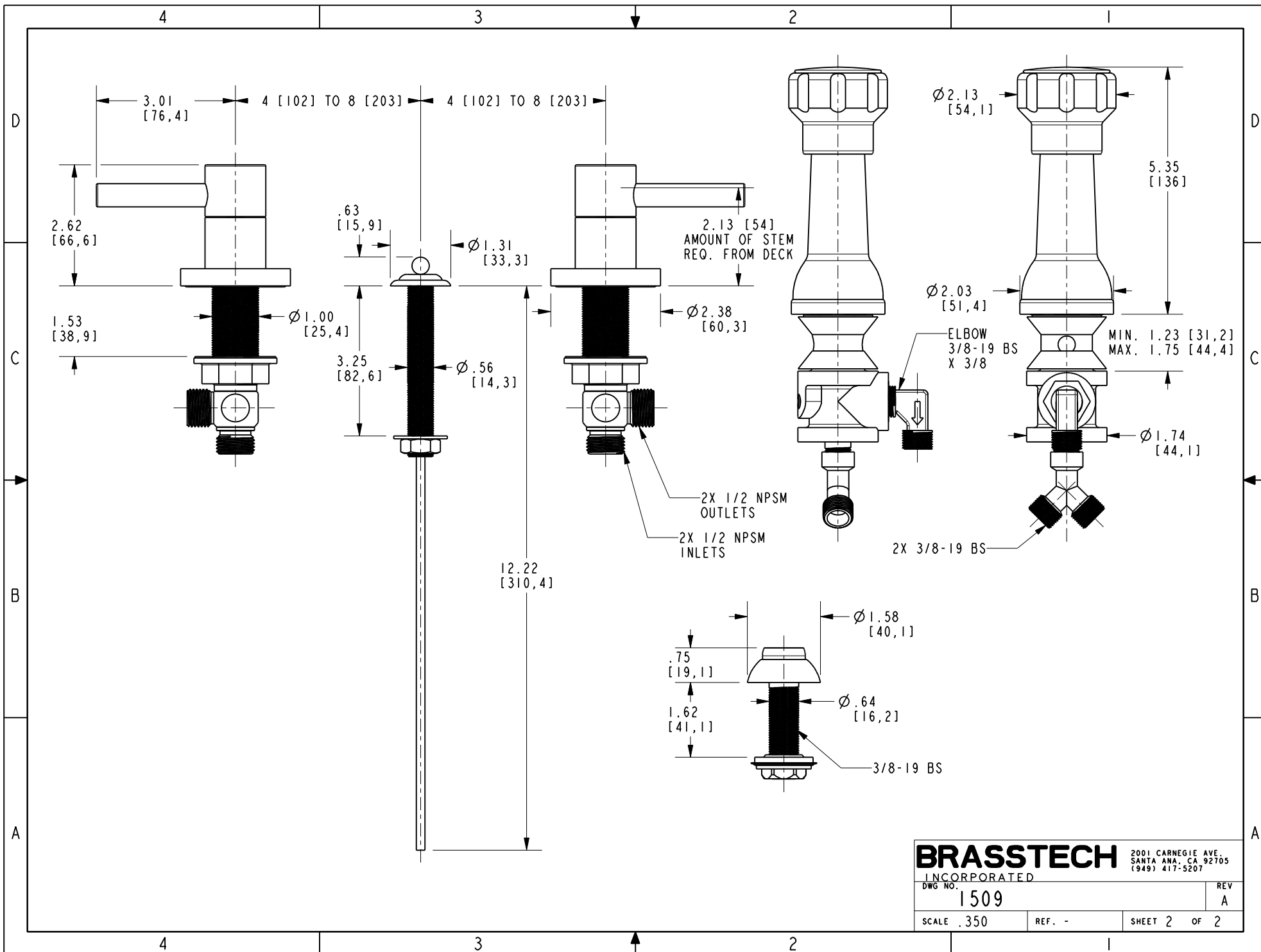

**BRASSTECH** INCORPORATED  
 2001 CARNEGIE AVE.  
 SANTA ANA, CA 92705  
 (949) 417-5207

DWG NO.	1509	REV	A
SCALE	.350	REF.	-
SHEET 2		OF 2	