

NOTES:

1. TO INSPECT ASSEMBLY, FOLLOW FIRST ARTICLE AND IN PROCESS INSPECTION SHEET.

BILL OF MATERIAL (CURRENT LEVEL)

ITEM	PT/ASSY	DESCRIPTION	TYPE	QTY.
1	1-525_1640	W/S VALVE ASM	ASSEMBLY	1
2	3-341	W/S SPOUT ASM	ASSEMBLY	1
3	3-280	HANDLE/ESCUTCHEON ASM	ASSEMBLY	2
4	1-131	FROID BUTTON W/ADH. TAB	ASSEMBLY	1
5	1-130	CHAUD BUTTON W/ADH. TAB	ASSEMBLY	1
6	10288	3/16" POP UP ROD	PART	1
7	11092	POP UP KNOB	PART	1
8	325	POP UP ASSEMBLY	ASSEMBLY	1

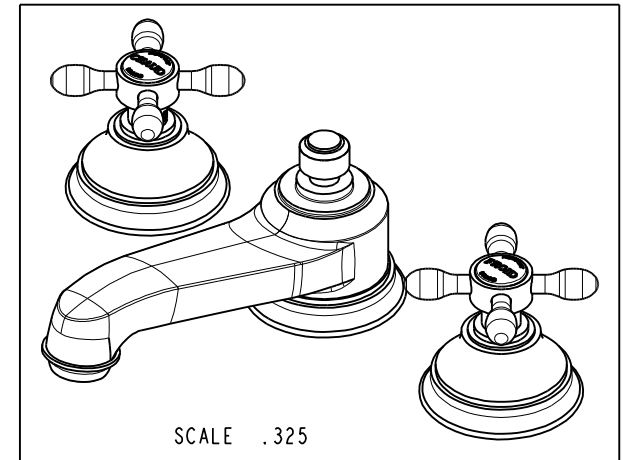
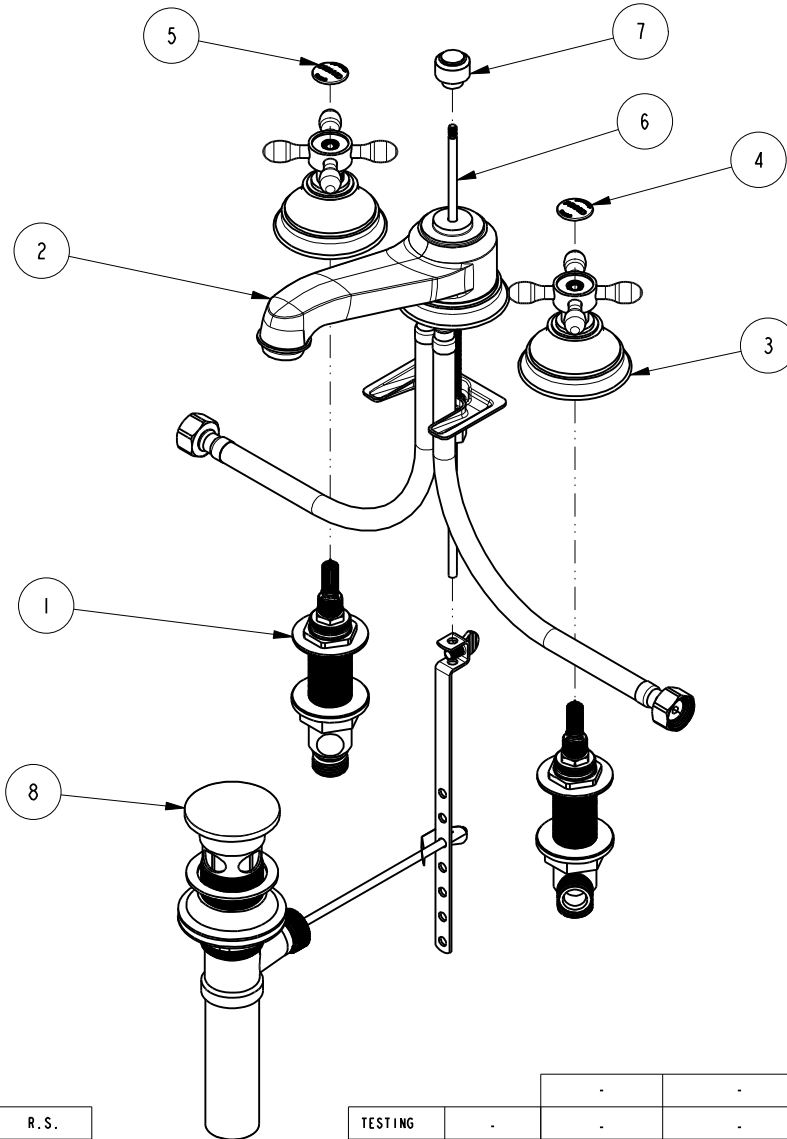

ZONE	REV	DESCRIPTION	DATE	APPROVED
-	D	EN-4300m	10/30/20	R.S.
-	C	EN-2553	07/02/13	-
-	B	EN-1616	09/13/10	-
-	A	EO-1004	06/12/08	-
-	-	EO-0299	03/04/04	-

COPYRIGHT 2005 BRASSTECH, INC. THESE DRAWINGS AND THE DESIGNS DEPICTED HEREIN ARE THE PROPRIETARY PROPERTY OF BRASSTECH. ANY USE OR REPRODUCTION IS SUBJECT TO THE EXPRESS APPROVAL OF BRASSTECH. UNAUTHORIZED USE IS STRICTLY PROHIBITED. ALL RIGHTS RESERVED.

TESTING	ASSEMBLY	PLATING	POLISHING	MACHINING	TOOLING FIXTURE #	APPLICATION
-	-	-	-	-	-	REMOVE ALL BURRS AND SHARP EDGES
-	-	-	-	-	-	USED ON
-	-	-	-	-	-	REMOVE ALL BURRS AND SHARP EDGES

UNITS ARE: INCHES [MM]		
TOLERANCES ARE:		
FRACTIONS	DECIMALS	ANGLES
±1/16"	.X ±.1 [2.5]	±°
	.XX ±.06 [1.5]	
(X.XXX) DENOTES CRITICAL DIMS.		
ALL THREADS ARE CRITICAL		
DRAWN	JINSON	10/30/20
CHECKED	R.S.	10/30/20
APPROVED	R.S.	10/30/20

BRASSTECH 2001 CARNEGIE AVE.
INCORPORATED SANTA ANA, CA 92705
(949) 417-5207

W/S FAUCET

DWG NO. **1640** REV **D**

SCALE .225 REF. - SHEET 1 OF 2

