

**BILL OF MATERIAL (CURRENT LEVEL)**

ITEM	PT/ASSY	DESCRIPTION	TYPE	QTY.
1	10288	3/16" POP UP ROD	PART	1
2	2-235	BIDET DIVERTER / V. BRE	ASSEMBLY	1
3	1-130	CHAUD BUTTON W/ADH. TAB	ASSEMBLY	1
4	2-236	DOUCHE SPRAY ASSEMBLY	ASSEMBLY	1
5	1-131	FROID BUTTON W/ADH. TAB	ASSEMBLY	1
6	3-280L	HANDLE/ESCUTCHEON ASM	ASSEMBLY	2
7	325	POP UP ASSEMBLY	ASSEMBLY	1
8	11092	POP UP KNOB	PART	1
9	2-159	POP-UP ROD GUIDE ASSEMBLY	ASSEMBLY	1
10	1-542	VALVE KIT - BIDET	ASSEMBLY	1

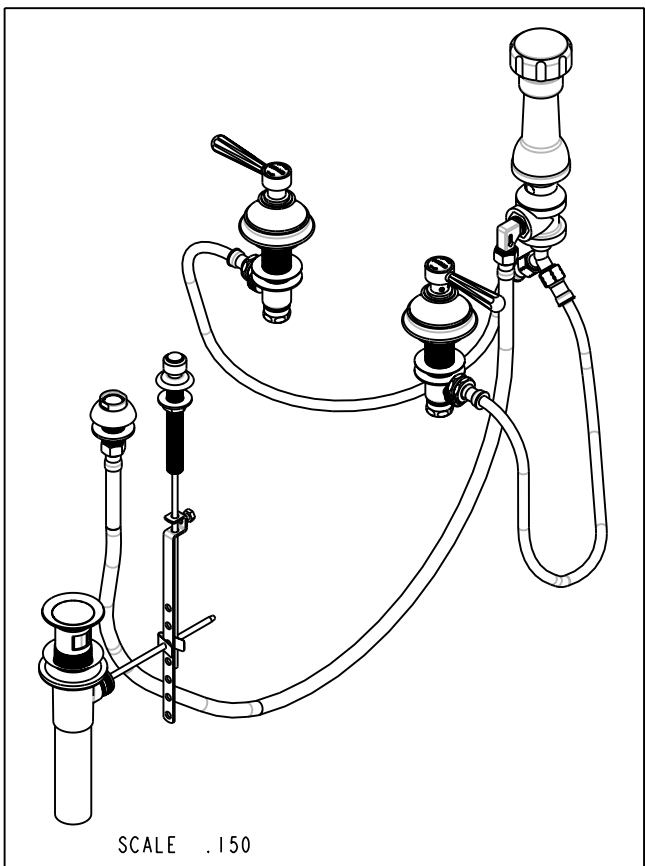

COPYRIGHT 2003 BRASSTECH, INC. THESE DRAWINGS AND THE DESIGNS DEPICTED HEREIN ARE THE PROPRIETARY PROPERTY OF BRASSTECH. ANY USE OR REPRODUCTION IS SUBJECT TO THE EXPRESS APPROVAL OF BRASSTECH. UNAUTHORIZED USE IS STRICTLY PROHIBITED. ALL RIGHTS RESERVED.

**BRASSTECH**  
INCORPORATED

2001 E. CARNEGIE AVE.  
SANTA ANA, CA 92705  
(949) 417-5207

**BIDET SET**

ASSY. NO.		1669				EO-0299		03/04/04	
SCALE .200	REF. -	SHEET	OF	REV	REV DESC	DATE			

**SPECIFICATION DWG**

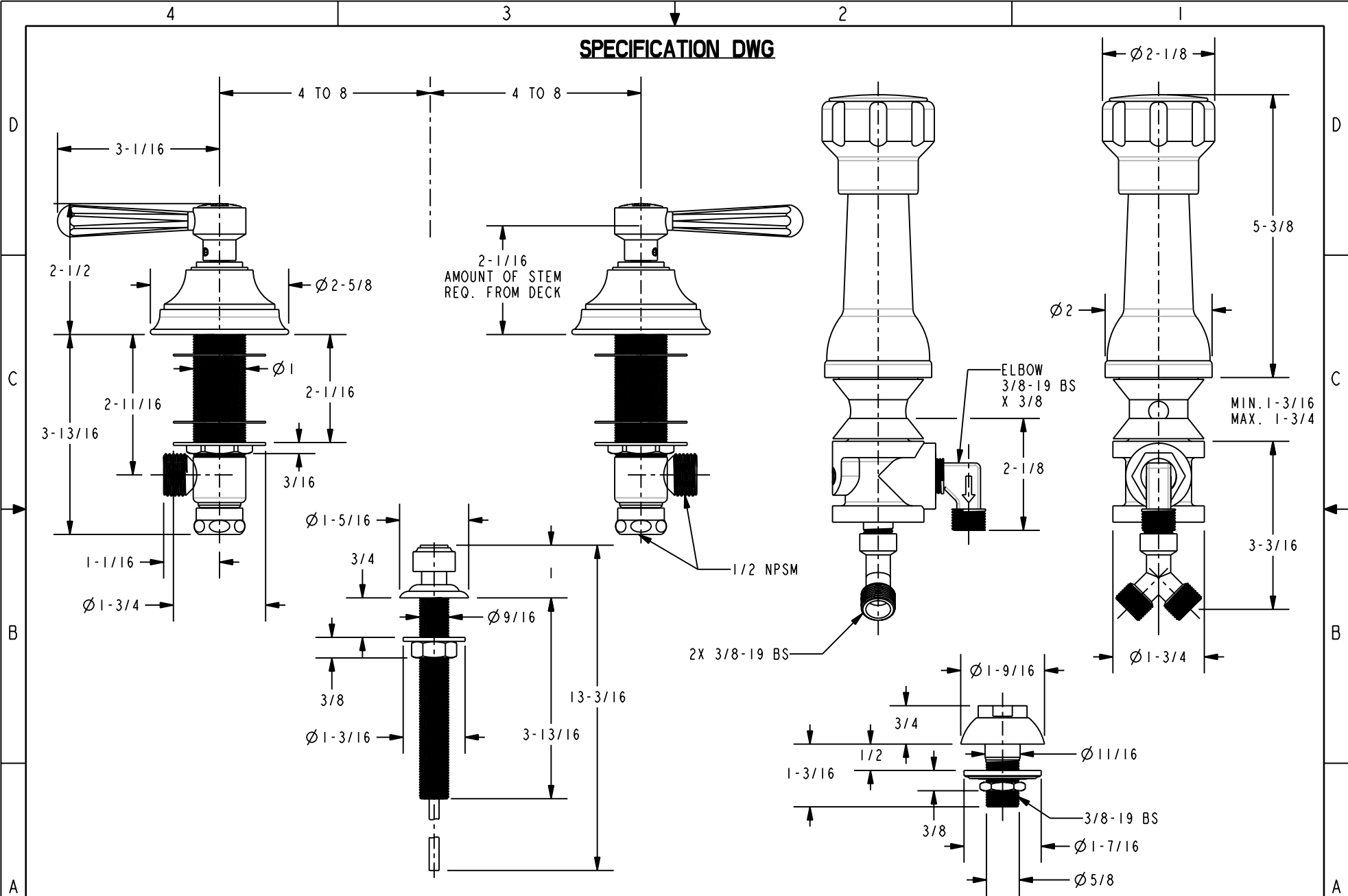

DIMENSIONS ARE IN INCHES AND AN APPROXIMATION OF A TYPICAL INSTALLATION

COPYRIGHT 2003 BRASSTECH, INC. THESE DRAWINGS AND THE DESIGNS DEPICTED HEREIN ARE THE PROPRIETARY PROPERTY OF BRASSTECH. ANY USE OR REPRODUCTION IS SUBJECT TO THE EXPRESS APPROVAL OF BRASSTECH. UNAUTHORIZED USE IS STRICTLY PROHIBITED. ALL RIGHTS RESERVED.

**BRASSTECH**  
INCORPORATED  
2001 E. CARNEGIE AVE.  
SANTA ANA, CA 92705  
(949) 417-5207

BIDET SET

ASSY. NO.		1669_SPEC			
SCALE .400	REF. -	SHEET 1	OF 1	REV	REV DESC
				EO-0299	03/04/04
				DATE	