

NOTES:

1. TO INSPECT ASSEMBLY, FOLLOW FIRST ARTICLE AND IN PROCESS INSPECTION SHEET.

BILL OF MATERIAL (CURRENT LEVEL)

ITEM	PT/ASSY	DESCRIPTION	TYPE	QTY.
1	1-525	W/S VALVE ASM	ASSEMBLY	1
2	3-348	W/S SPOUT ASM	ASSEMBLY	1
3	10288	3/16" POP UP ROD	PART	1
4	11181	POP-UP KNOB	PART	1
5	10048	ESCUTCHEON W/S VALVE	PART	2
6	10095	ESCUTCHEON, 900 SERIES	PART	2
7	2-470	LEVER HANDLE ASM W/8 FLATS	ASSEMBLY	2
8	325	POP UP ASSEMBLY	ASSEMBLY	1
9	91753	O-RING, # 2-136, EP, 50 DURO - GREY	PART	2

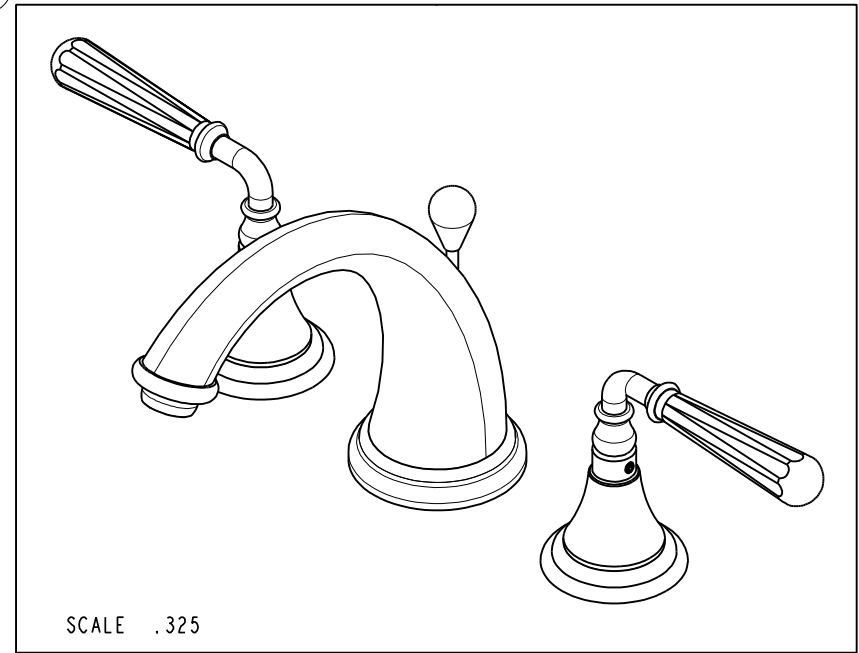
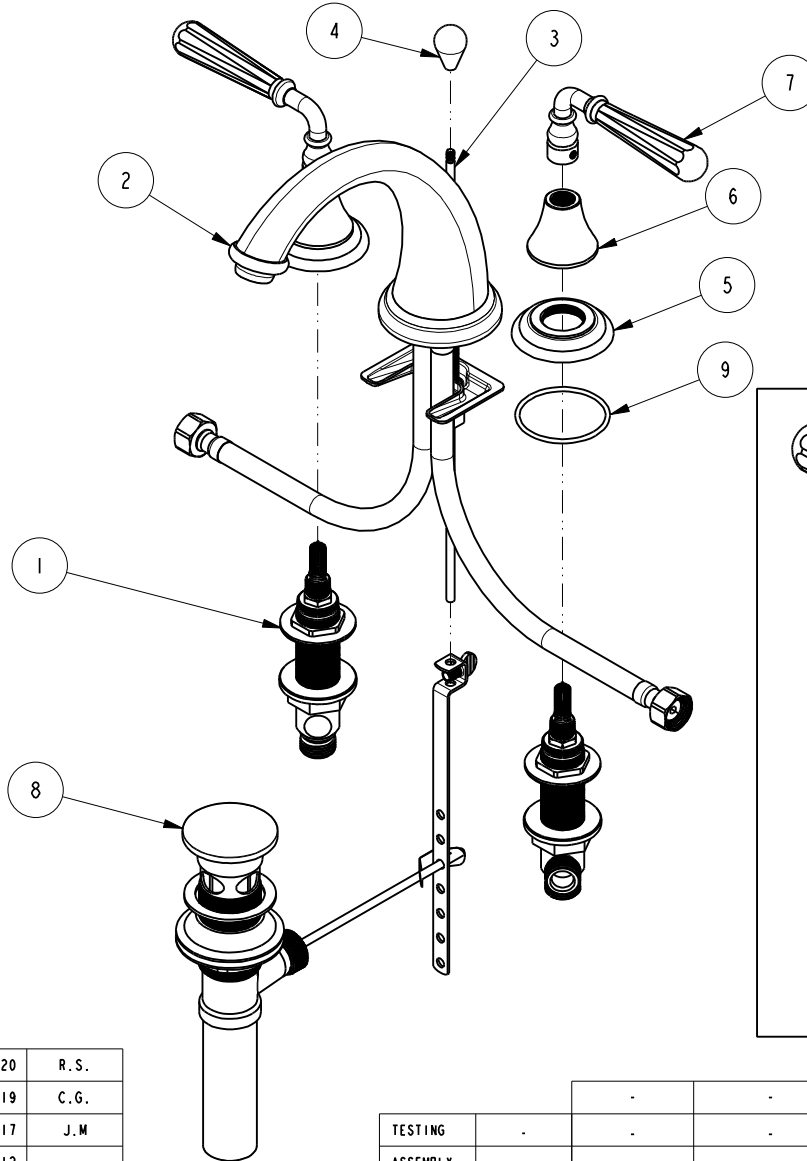

ZONE	REV	DESCRIPTION	DATE	APPROVED
-	F	EN-4300m	10/30/20	R.S.
-	E	EN-3722	02/08/19	C.G.
-	D	EN-3371	08/04/17	J.M
-	C	EN-2334	12/18/12	-
-	B	EN-1616	09/13/10	-
-	A	EO-1018	06/10/08	-
-	-	EO-0390	07/16/04	-

COPYRIGHT 2005 BRASSTECH, INC. THESE DRAWINGS AND THE DESIGNS DEPICTED HEREIN ARE THE PROPRIETARY PROPERTY OF BRASSTECH. ANY USE OR REPRODUCTION IS SUBJECT TO THE EXPRESS APPROVAL OF BRASSTECH. UNAUTHORIZED USE IS STRICTLY PROHIBITED. ALL RIGHTS RESERVED.

TESTING	ASSEMBLY	PLATING	POLISHING	MACHINING	TOOLING FIXTURE #	APPLICATION
-	-	-	-	-	-	REMOVE ALL BURRS AND SHARP EDGES
-	-	-	-	-	-	USED ON
-	-	-	-	-	-	REMOVE ALL BURRS AND SHARP EDGES

UNITS ARE: INCHES [MM]  
TOLERANCES ARE:  
FRACTIONS DECIMALS ANGLES  
±1/16" .X ±.1 [2,5] ±1°  
.XX ±.06 [1,5]

(X.XXX) DENOTES CRITICAL DIMS.  
ALL THREADS ARE CRITICAL

DRAWN	JINSON	10/30/20
CHECKED	R.S.	10/30/20
APPROVED	R.S.	10/30/20

**BRASSTECH** INCORPORATED  
2001 CARNEGIE AVE.  
SANTA ANA, CA 92705  
(949) 417-5207

WIDESPREAD FAUCET ASM

DWG NO.	REV	SCALE	REF.	SHEET	OF
1740	F	.225	-	1	2

