

NOTES:

1. TO INSPECT ASSEMBLY, FOLLOW FIRST ARTICLE AND IN PROCESS INSPECTION SHEET.

2. APPLY LOCTITE 680.

BILL OF MATERIAL (CURRENT LEVEL)

ITEM	PT/ASSY	DESCRIPTION	TYPE	QTY.
1	10313	SMOOTH BASE RING	PART	1
2	10086	TUB SPOUT	PART	1
3	12391	KNURL TIP W/M SPOUT	PART	1
4	91755	O-RING, #2-142, EPDM, 50 DURO - GREY	PART	1

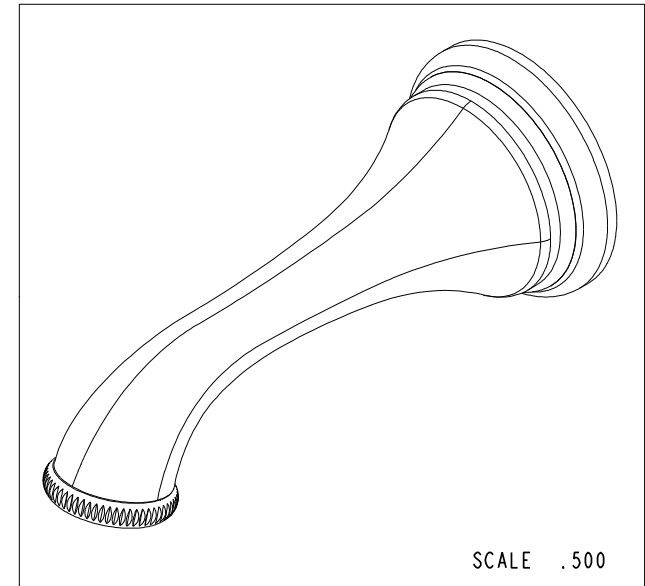
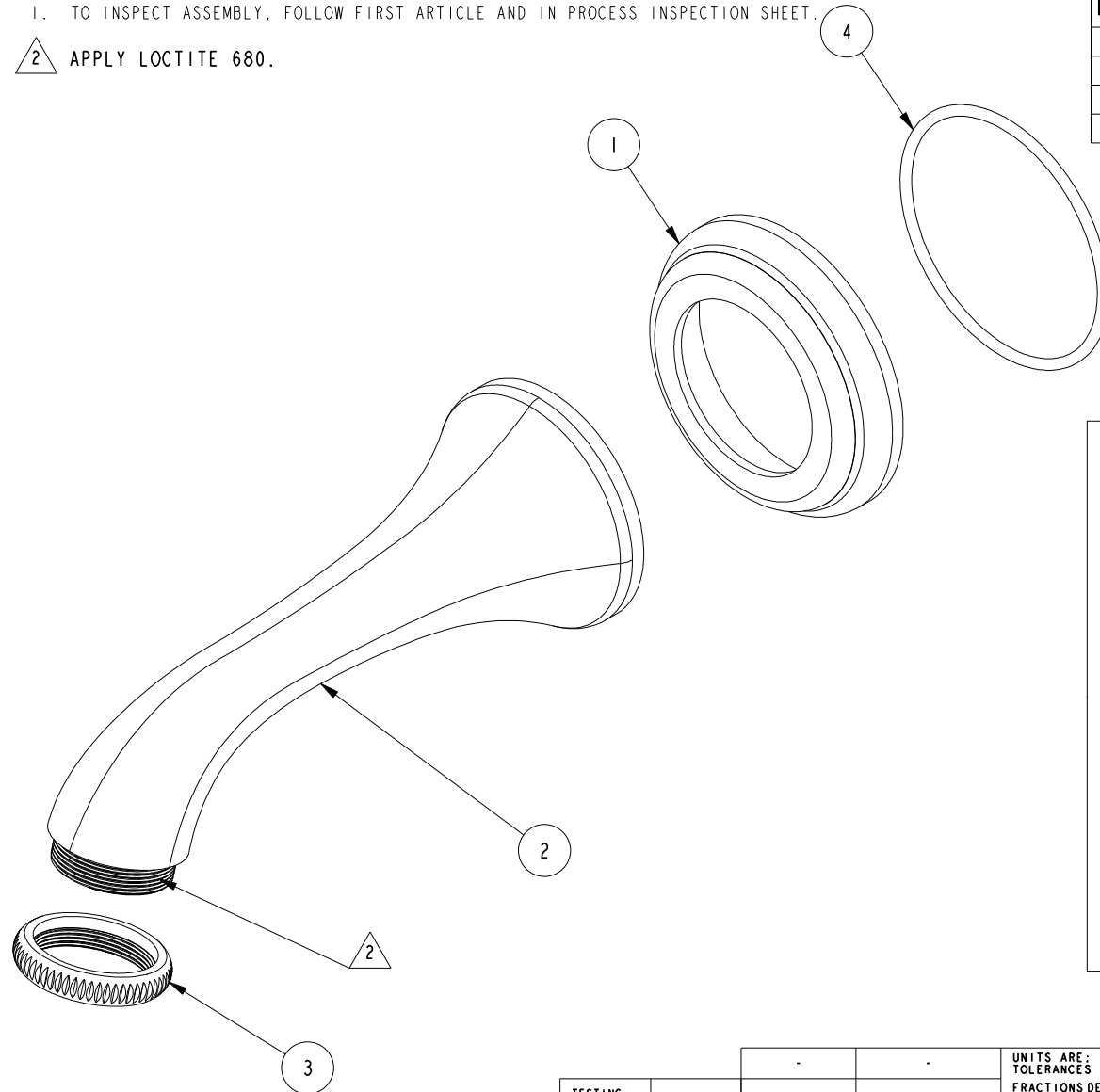

TESTING	-	-	-
ASSEMBLY	-	-	-
PLATING	-	3-2905, 3-2915	3-2905, 3-2915
POLISHING	-	NEXT ASSY	USED ON
MACHINING	-	APPLICATION	
TOOLING FIXTURE #	REMOVE ALL BURRS AND SHARP EDGES		

UNITS ARE: INCHES [MM]		
TOLERANCES ARE:		
FRACTIONS	DECIMALS	ANGLES
±1/16"	.X ±.1 [2.5]	±1°
	.XX ±.06 [1.5]	
(X.XXX) DENOTES CRITICAL DIMS.		
ALL THREADS ARE CRITICAL		
DRAWN	MANJUNATH	02/08/19
CHECKED	C.G.	02/08/19
APPROVED	C.G.	02/08/19

BRASSTECH 2001 CARNEGIE AVE.
INCORPORATED SANTA ANA, CA 92705
(949) 417-5207

WALL MOUNT TUB SPOUT

-	B	EN-4300ii	01/25/21	R.S.
-	A	EN-3722	02/08/19	C.G.
-	-	EN-2838c	05/04/15	J.M.
ZONE	REV	DESCRIPTION	DATE	APPROVED

COPYRIGHT 2005 BRASSTECH, INC. THESE DRAWINGS AND THE DESIGNS DEPICTED HEREIN ARE THE PROPRIETARY PROPERTY OF BRASSTECH. ANY USE OR REPRODUCTION IS SUBJECT TO THE EXPRESS APPROVAL OF BRASSTECH. UNAUTHORIZED USE IS STRICTLY PROHIBITED. ALL RIGHTS RESERVED.

DWG NO.	20-131	REV	B
SCALE	.625	REF.	SHEET 1 OF 2

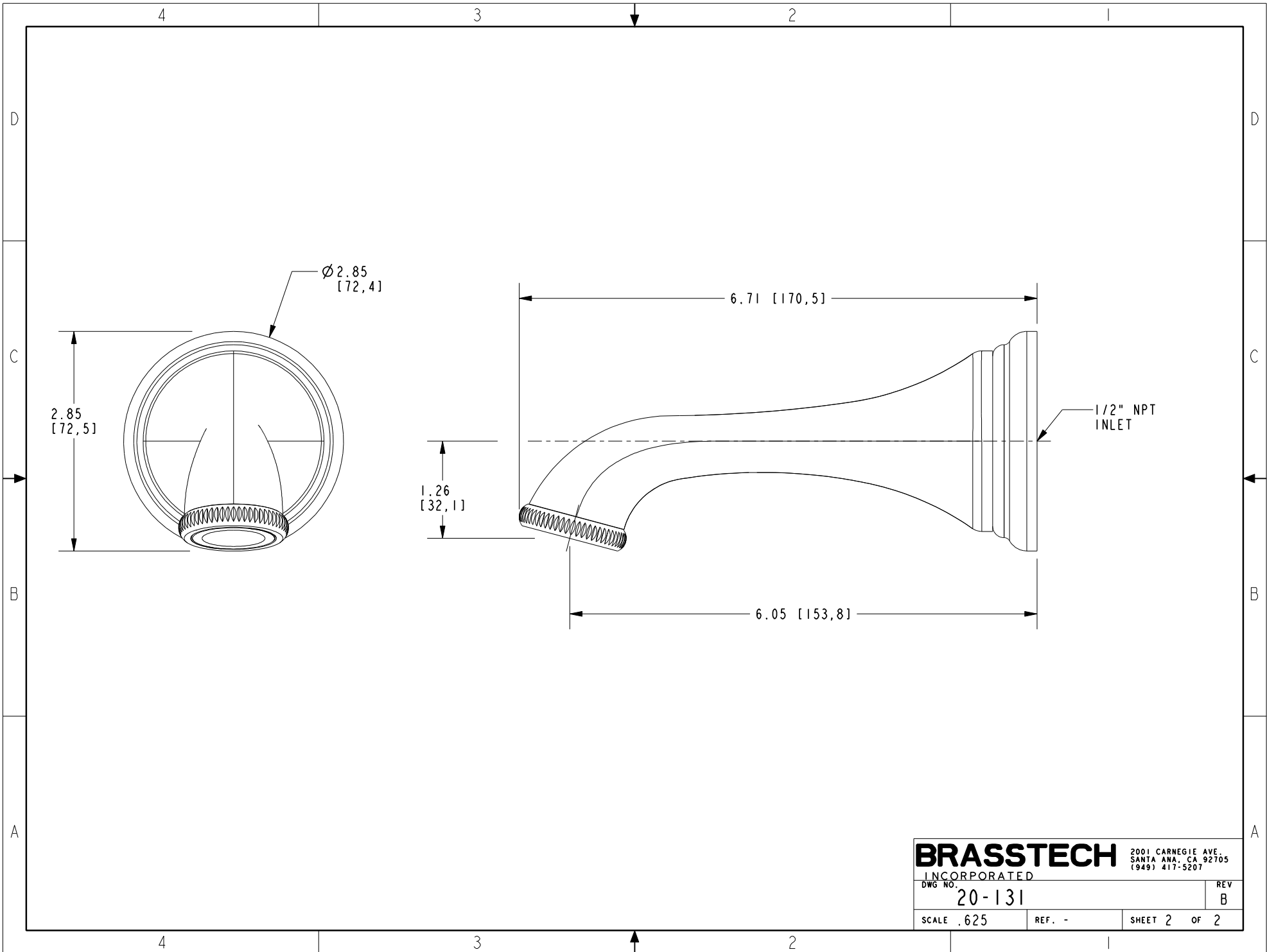

BRASSTECH		2001 CARNEGIE AVE. SANTA ANA, CA 92705 (949) 417-5207	
INCORPORATED			
DWG NO.	20-131	REV	B
SCALE	.625	REF.	-
		SHEET	2 OF 2