

NOTES:

1. TO INSPECT ASSEMBLY, FOLLOW FIRST ARTICLE AND IN PROCESS INSPECTION SHEET.

BILL OF MATERIAL (CURRENT LEVEL)

ITEM	PT/ASSY	DESCRIPTION	TYPE	QTY.
1	1995	MOUNTING FLANGE	PART	2
2	199X	GRAB BAR MOUNTING HARDWARE PACK	ASSEMBLY	2
3	5085SQ	36" GRAB BAR BRAZE ASM	ASSEMBLY	1
4	5272	GRAB BAR ROSETTE	PART	2
5	92308	SCRW, M5 X 5 SKT HD CUP PT W/ SELF LOC SS	PART	2

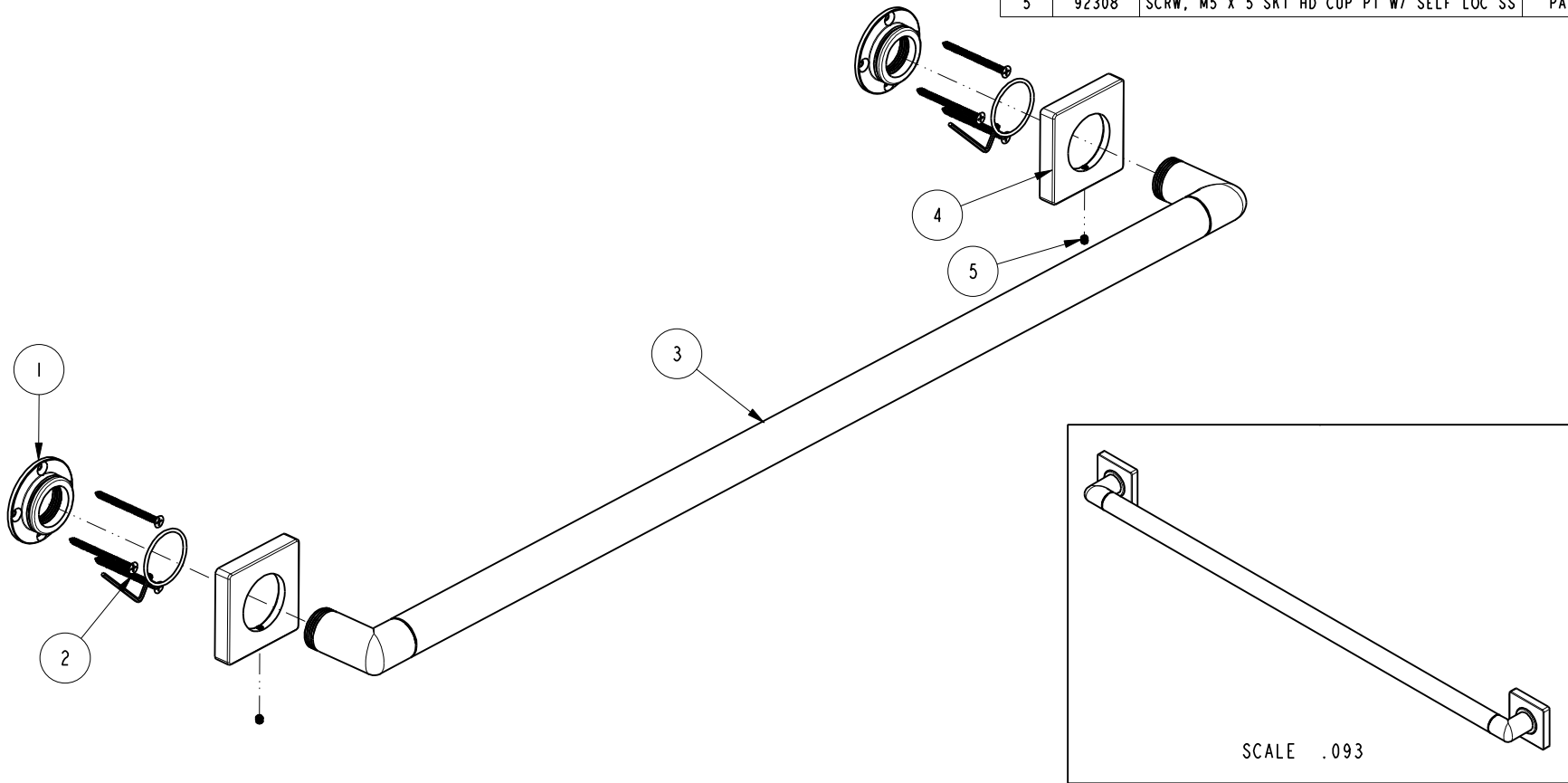

ZONE	REV	DESCRIPTION	DATE	APPROVED
-	B	EN-4300i	06/22/21	R.S.
-	A	EN-4143	03/20/20	J.M.
-	-	EN-3279b	07/03/17	J.M.

COPYRIGHT 2005 BRASSTECH, INC. THESE DRAWINGS AND THE DESIGNS DEPICTED HEREIN ARE THE PROPRIETARY PROPERTY OF BRASSTECH. ANY USE OR REPRODUCTION IS SUBJECT TO THE EXPRESS APPROVAL OF BRASSTECH. UNAUTHORIZED USE IS STRICTLY PROHIBITED. ALL RIGHTS RESERVED.

TESTING	ASSEMBLY	PLATING	POLISHING	MACHINING	TOOLING FIXTURE #	APPLICATION
-	-	-	-	-	-	REMOVE ALL BURRS AND SHARP EDGES

UNITS ARE: INCHES [MM]	
TOLERANCES ARE:	
FRACTIONS DECIMALS	ANGLES
±1/16"	±1°
.X ±.1 [2,5]	
.XX ±.06 [1,5]	
(X.XXX) DENOTES CRITICAL DIMS.	
ALL THREADS ARE CRITICAL	
DRAWN	JINSON
06/22/21	
CHECKED	R.S.
06/22/21	
APPROVED	R.S.
06/22/21	

BRASSTECH 2001 CARNEGIE AVE. SANTA ANA, CA 92705 (949) 417-5207
INCORPORATED

GRAB BAR 36"

DWG NO. **2040-3936** REV **B**

SCALE **.200** REF. - SHEET **1** OF **2**

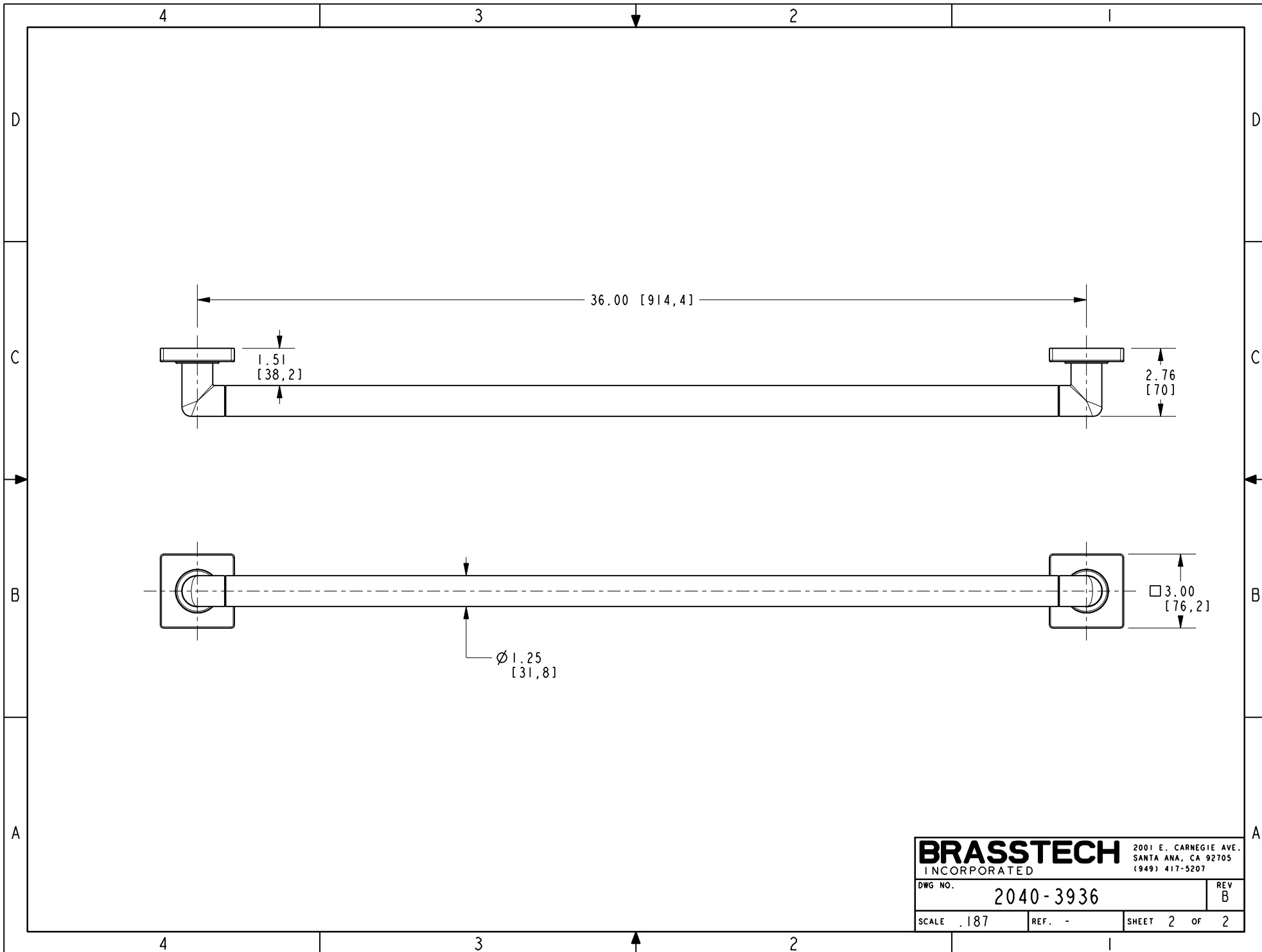

BRASSTECH 2001 E. CARNEGIE AVE.
 INCORPORATED SANTA ANA, CA 92705
 (949) 417-5207

DWG NO.	2040-3936	REV	B
SCALE	.187	REF.	-
SHEET 2		OF 2	