

REPLACEMENT PARTS

ITEM	PT/ASSY	SPECIFY FINISH	DESCRIPTION
1	10-327		GASKET & FLOW REGULATOR SUB ASM

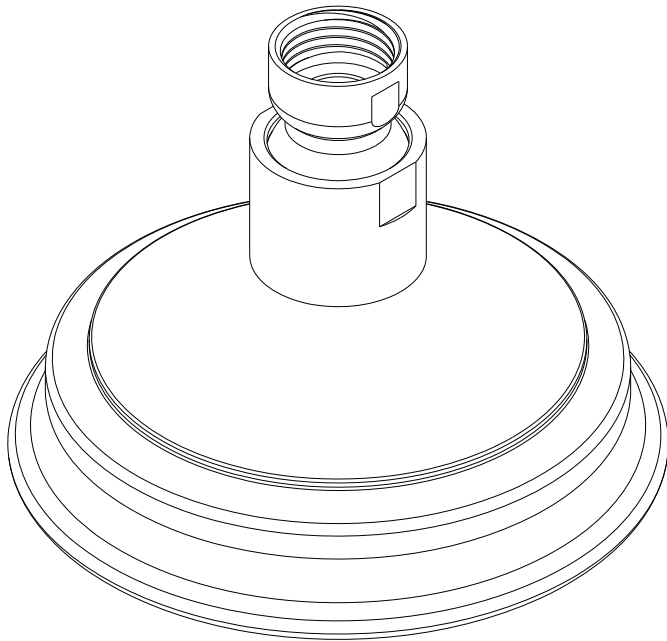
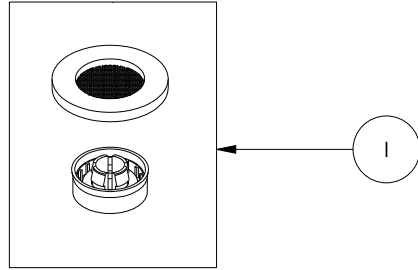

SHOWER HEAD, TRAD
2156

REV G EN-4859 08/02/24

NEWPORT BRASS.

t: 949.417.5207 | www.newportbrass.com