

NOTES:

1. TO INSPECT ASSEMBLY, FOLLOW FIRST ARTICLE AND IN PROCESS INSPECTION SHEET.

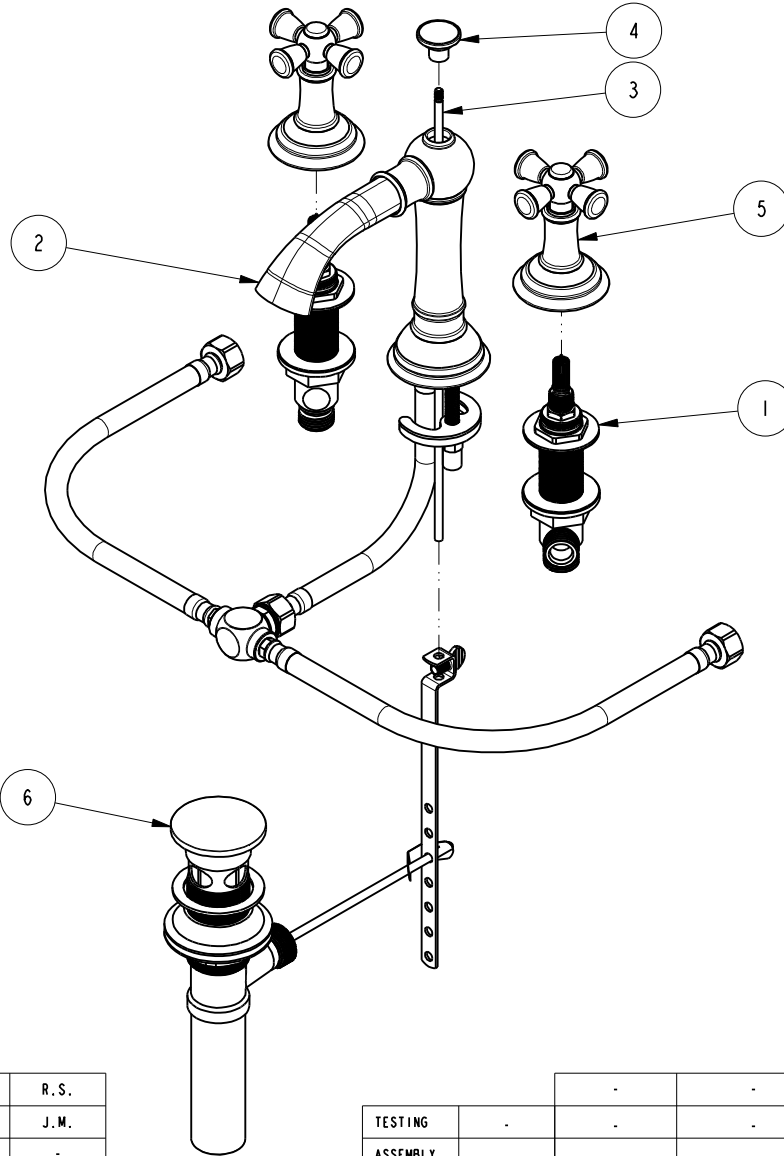

BILL OF MATERIAL (CURRENT LEVEL)

ITEM	PT/ASSY	DESCRIPTION	TYPE	QTY.
1	1-525	W/S VALVE ASM	ASSEMBLY	1
2	2-767	W/S SPOUT ASM	ASSEMBLY	1
3	10288	3/16" POP UP ROD	PART	1
4	11583	POP-UP KNOB	PART	1
5	3-374	CROSS HANDLE AND ESC. ASM	ASSEMBLY	2
6	325	POP UP ASSEMBLY	ASSEMBLY	1

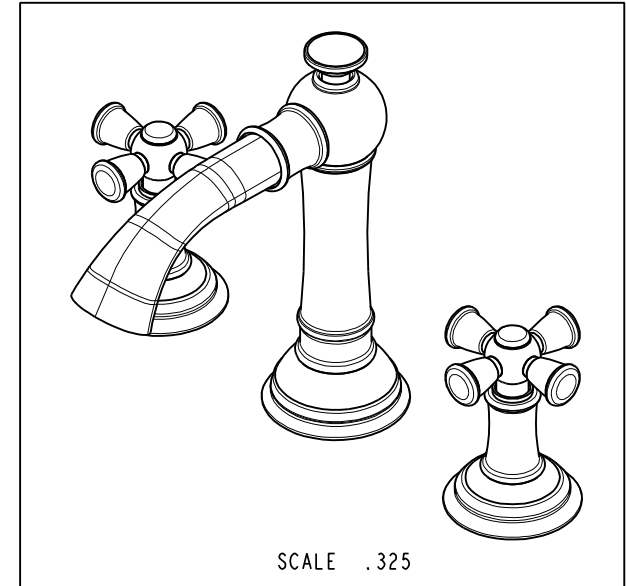

-	E	EN-4300m	11/03/20	R.S.
-	D	EN-3764	12/07/18	J.M.
-	C	EN-2120	04/05/12	-
-	B	EN-1844	09/01/11	-
-	A	EN-1616	09/13/10	-
-	-	EN-1266	04/23/10	-
ZONE	REV	DESCRIPTION	DATE	APPROVED

COPYRIGHT 2005 BRASSTECH, INC. THESE DRAWINGS AND THE DESIGNS DEPICTED HEREIN ARE THE PROPRIETARY PROPERTY OF BRASSTECH. ANY USE OR REPRODUCTION IS SUBJECT TO THE EXPRESS APPROVAL OF BRASSTECH. UNAUTHORIZED USE IS STRICTLY PROHIBITED. ALL RIGHTS RESERVED.

TESTING	-	-	-
ASSEMBLY	-	-	-
PLATING	-	-	-
POLISHING	-	NEXT ASSY	USED ON
MACHINING	-	APPLICATION	
TOOLING FIXTURE #	REMOVE ALL BURRS AND SHARP EDGES		

UNITS ARE: INCHES [MM]  
TOLERANCES ARE:  
FRACTIONS DECIMALS ANGLES  
±1/16" .X ±.1 [2,5] ±1°  
.XX ±.06 [1,5]

(X.XXX) DENOTES CRITICAL DIMS.  
ALL THREADS ARE CRITICAL

DRAWN	JINSON	11/03/20
CHECKED	R.S.	11/03/20
APPROVED	R.S.	11/03/20

**BRASSTECH**  
INCORPORATED

2001 CARNEGIE AVE.  
SANTA ANA, CA 92705  
(949) 417-5207

W/S LAVATORY FAUCET

DWG NO. 2400

SCALE .225

REF. -

SHEET 1 OF 2

REV E

