

NOTES:

1. TO INSPECT ASSEMBLY, FOLLOW FIRST ARTICLE AND IN PROCESS INSPECTION SHEET.

BILL OF MATERIAL (CURRENT LEVEL)

ITEM	PT/ASSY	DESCRIPTION	TYPE	QTY.
1	1-525	W/S VALVE ASM	ASSEMBLY	1
2	2-768	W/S SPOUT ASM	ASSEMBLY	1
3	10288	3/16" POP UP ROD	PART	1
4	11583	POP-UP KNOB	PART	1
5	3-373	LEVER HANDLE AND ESC. ASM	ASSEMBLY	2
6	325	POP UP ASSEMBLY	ASSEMBLY	1

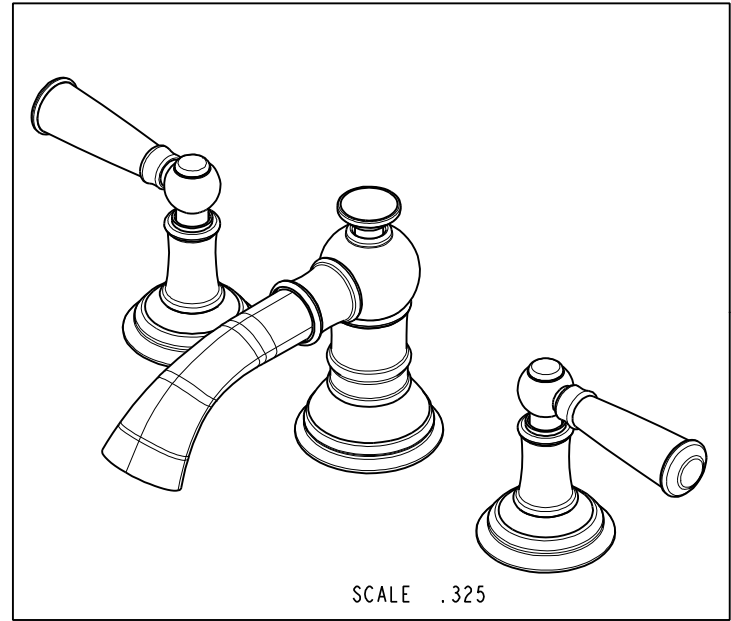
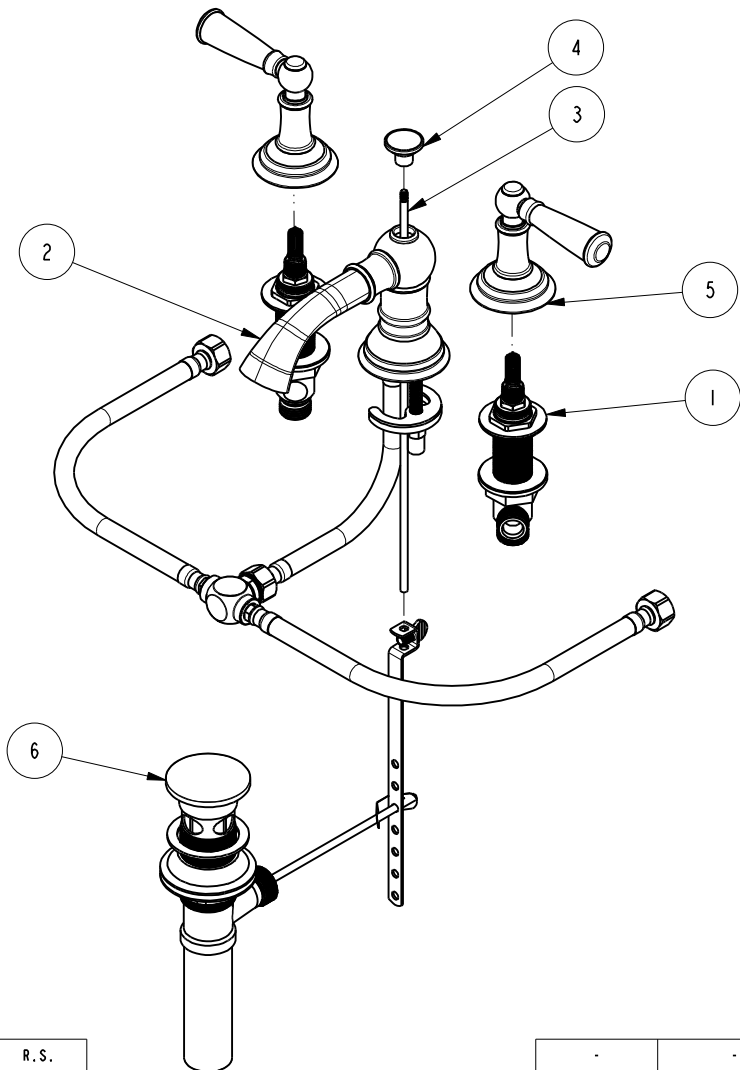

ZONE	REV	DESCRIPTION	DATE	APPROVED
-	E	EN-4300m	11/03/20	R.S.
-	D	EN-3764	12/07/18	J.M.
-	C	EN-2120	04/05/12	-
-	B	EN-1844	09/01/11	-
-	A	EN-1616	09/13/10	-
-	-	EN-1266	05/05/10	-

COPYRIGHT 2005 BRASSTECH, INC. THESE DRAWINGS AND THE DESIGNS DEPICTED HEREIN ARE THE PROPRIETARY PROPERTY OF BRASSTECH. ANY USE OR REPRODUCTION IS SUBJECT TO THE EXPRESS APPROVAL OF BRASSTECH. UNAUTHORIZED USE IS STRICTLY PROHIBITED. ALL RIGHTS RESERVED.

TESTING	ASSEMBLY	PLATING	POLISHING	MACHINING	TOOLING FIXTURE #	APPLICATION
-	-	-	-	-	-	REMOVE ALL BURRS AND SHARP EDGES

UNITS ARE: INCHES [MM]		
TOLERANCES ARE:		
FRACTIONS	DECIMALS	ANGLES
±1/16"	.X ±.1 [2.5]	±1°
	.XX ±.06 [1.5]	
(X.XXX) DENOTES CRITICAL DIMS.		
ALL THREADS ARE CRITICAL		
DRAWN	JINSON	11/03/20
CHECKED	R.S.	11/03/20
APPROVED	R.S.	11/03/20

BRASSTECH 2001 CARNEGIE AVE. SANTA ANA, CA 92705 (949) 417-5207
INCORPORATED

W/S LAVATORY FAUCET

DWG NO. **2430** REV **E**

SCALE .200 REF. - SHEET 1 OF 2

