

REPLACEMENT PARTS

NOTE:

 USE SILICON GREASE (PART NUMBER 6727) TO LUBRICATE O-RINGS BEFORE INSTALLING.

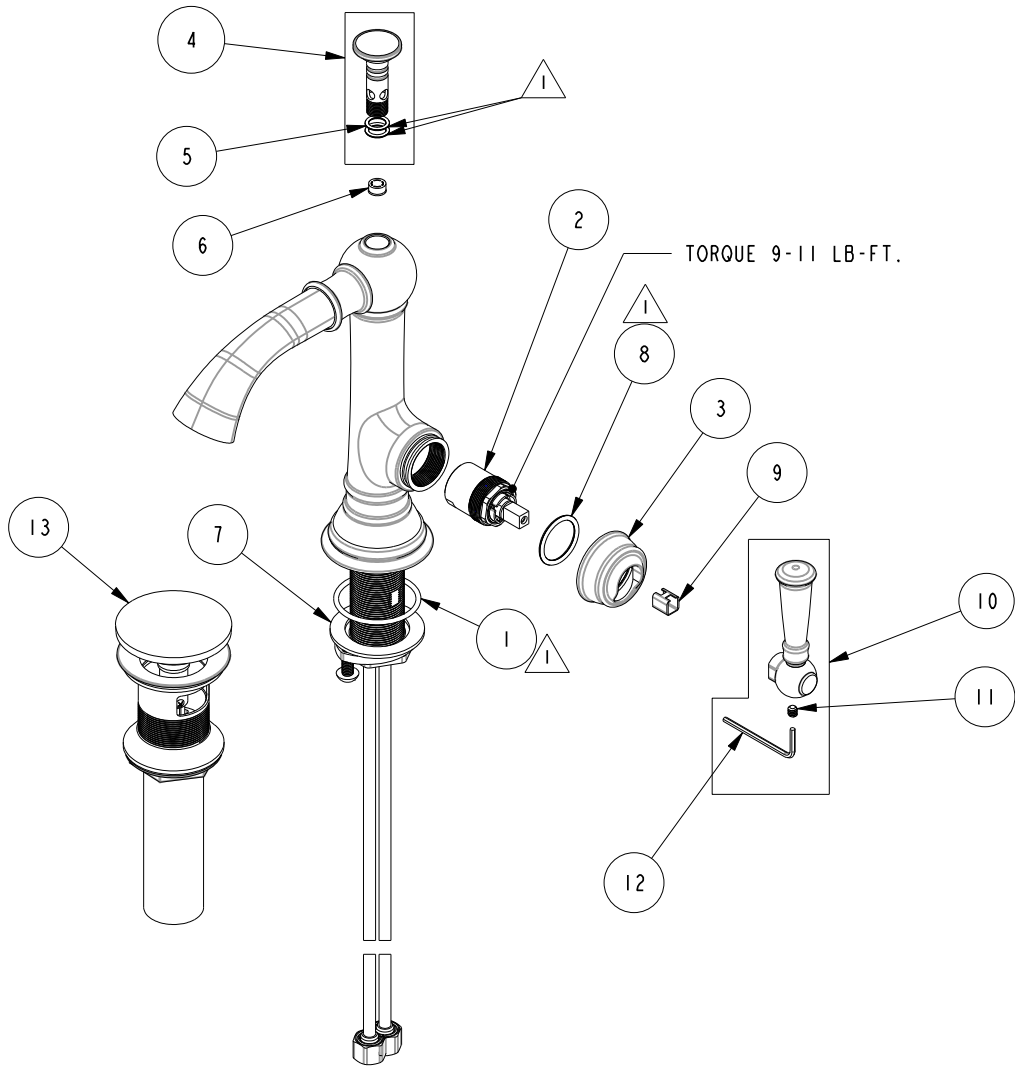

ITEM	PT/ASSY	SPECIFY FINISH	DESCRIPTION
1	91768		O-RING, #2-130, EP, 50 DURO - GREY
2	1-371		CARTRIDGE
3	30785		HANDLE BONNET
4	2-833	YES	FINIAL ASM
5	91017		O-RING #2-012
6	12400		FLOW REGULATOR, 1.2 GPM, PINK
7	1-393		1-1/8 18 UNEF MOUNTING KIT
8	91288		O-RING, #2-119, EPDM, 65-75 DURO
9	91534		CARTRIDGE STEM INSERT
10	2-832	YES	LEVER ASM
11	92104		SCRW, 10-24 X 3/16 SKT HD CUP PT SS
12	10159		HEX KEY, 3/32 ALLOY STEEL
13	330	YES	DRAIN, PUSH DOWN, W/ OVERFLOW

Single Hole Lavatory Faucet
2433

NEWPORT BRASS.