

NOTES:

1. TO INSPECT ASSEMBLY, FOLLOW FIRST ARTICLE AND IN PROCESS INSPECTION SHEET.

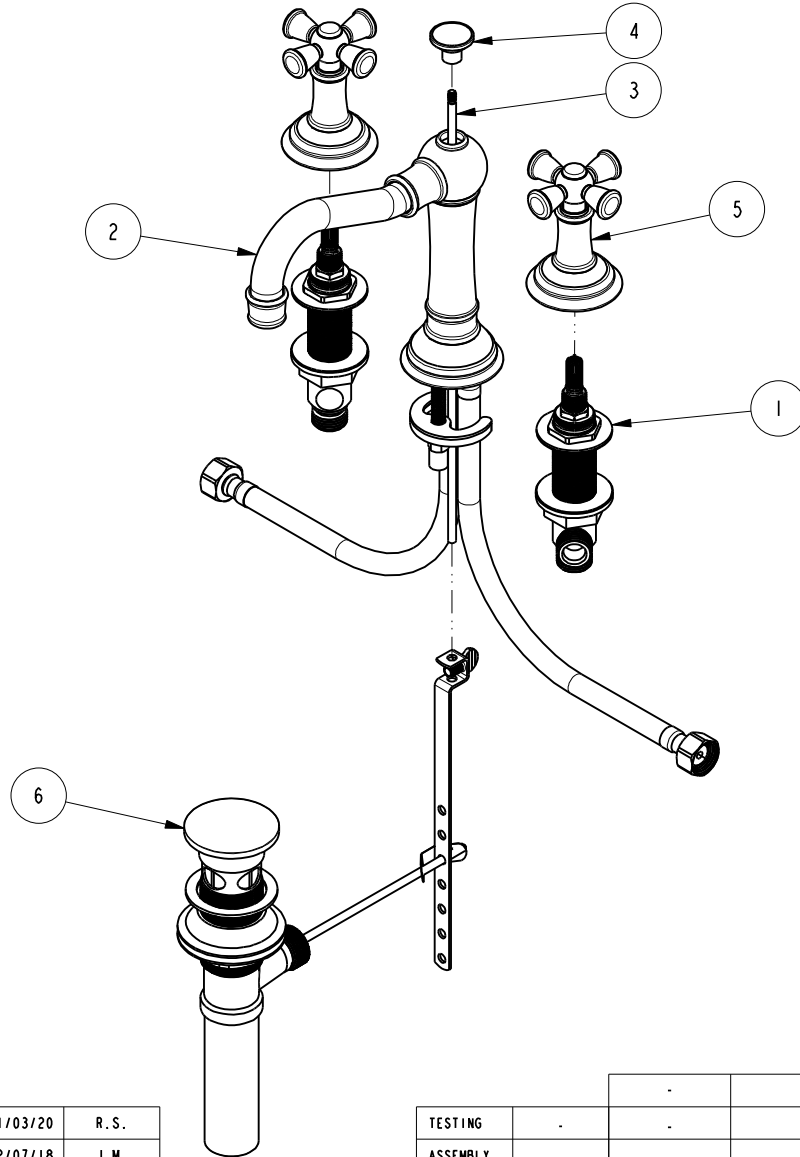

BILL OF MATERIAL (CURRENT LEVEL)

ITEM	PT/ASSY	DESCRIPTION	TYPE	QTY.
1	1-525	W/S VALVE ASM	ASSEMBLY	1
2	3-435	SPOUT ASM WITH ESCUTCHEON	ASSEMBLY	1
3	10288	3/16" POP UP ROD	PART	1
4	11583	POP-UP KNOB	PART	1
5	3-374	CROSS HANDLE AND ESC. ASM	ASSEMBLY	2
6	325	POP UP ASSEMBLY	ASSEMBLY	1

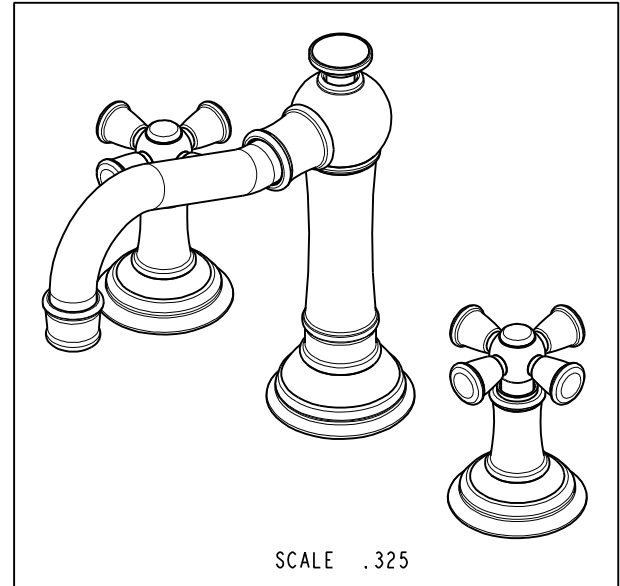

ZONE	REV	DESCRIPTION	DATE	APPROVED
-	D	EN-4300m	11/03/20	R.S.
-	C	EN-3746	12/07/18	J.M.
-	B	EN-1844	09/01/11	-
-	A	EN-1616	09/13/10	-
-	-	EN-1266	05/05/10	-

COPYRIGHT 2005 BRASSTECH, INC. THESE DRAWINGS AND THE DESIGNS DEPICTED HEREIN ARE THE PROPRIETARY PROPERTY OF BRASSTECH. ANY USE OR REPRODUCTION IS SUBJECT TO THE EXPRESS APPROVAL OF BRASSTECH. UNAUTHORIZED USE IS STRICTLY PROHIBITED. ALL RIGHTS RESERVED.

TESTING	-	-	-
ASSEMBLY	-	-	-
PLATING	-	-	-
POLISHING	-	NEXT ASSY	USED ON
MACHINING	-	APPLICATION	
TOOLING FIXTURE #	REMOVE ALL BURRS AND SHARP EDGES		

UNITS ARE: INCHES [MM]
TOLERANCES ARE:
FRACTIONS DECIMALS ANGLES
±1/16" .X ±.1 [2,5] ±1°
.XX ±.06 [1,5]

(X.XXX) DENOTES CRITICAL DIMS.
ALL THREADS ARE CRITICAL

DRAWN	JINSON	11/03/20
CHECKED	R.S.	11/03/20
APPROVED	R.S.	11/03/20

BRASSTECH 2001 CARNEGIE AVE.
INCORPORATED SANTA ANA, CA 92705
(949) 417-5207

W/S LAVATORY FAUCET

DWG NO. 2460 REV D

SCALE .225 REF. - SHEET 1 OF 2

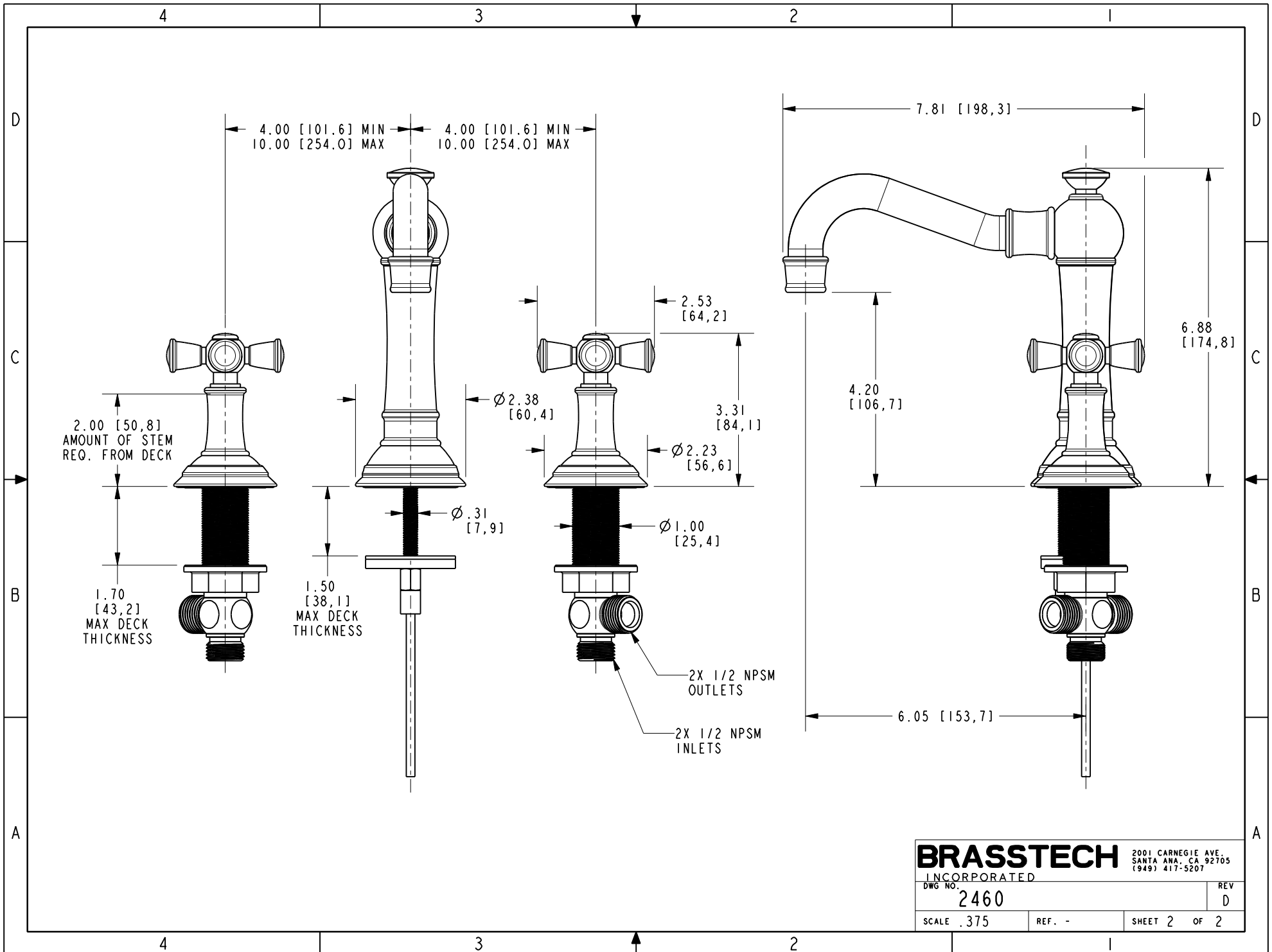

BRASSTECH		2001 CARNEGIE AVE. SANTA ANA, CA 92705 (949) 417-5207	
INCORPORATED			
DWG NO.	2460	REV	D
SCALE	.375	REF.	-
		SHEET	2 OF 2