

BILL OF MATERIAL (CURRENT LEVEL)				
ITEM	PT/ASSY	DESCRIPTION	TYPE	QTY.
1	2-800	SIDE SPRAY ESCUTCHEON - ASSEMBLY	ASSEMBLY	1
2	11720	SPRAY HANDLE	PART	1
3	91219	WSHR .385 ID X .745 OD X .114 THK, FLT, NYLON, NSF 61	PART	1
4	91218	WSHR .295 ID X .745 OD X .063 THK, FLT, EPDM, 75-85 DURO, PWB# 61	PART	1
5	2-708	SPRAY HEAD ASM	ASSEMBLY	1
6	12021	HOSE, SPRAY, FEMALE CONNECTOR	PART	1
7	10451	SPLIT RING	PART	1
8	50967	NIPPLE -SIDE SPRAY	PART	1
9	91580	O-RING, 3 X 19MM ID, EPDM, 65-75 DURO	PART	1
10	1-393	1-1/8 18 UNEF MOUNTING KIT	ASSEMBLY	1

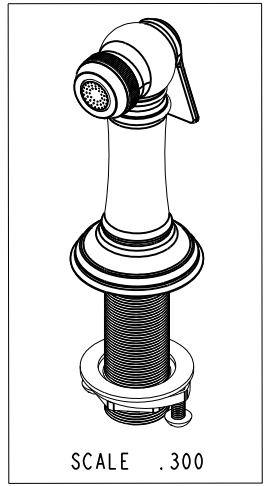

COPYRIGHT 2005 BRASSTECH, INC. THESE DRAWINGS AND THE DESIGNS DEPICTED HEREIN ARE THE PROPRIETARY PROPERTY OF BRASSTECH. ANY USE OR REPRODUCTION IS SUBJECT TO THE EXPRESS APPROVAL OF BRASSTECH. UNAUTHORIZED USE IS STRICTLY PROHIBITED. ALL RIGHTS RESERVED.

BRASSTECH
INCORPORATED
2001 E. CARNEGIE AVE.
SANTA ANA, CA 92705
(949) 417-5207

JACOBAN SIDE SPRAY

ASSY. NO. 2470-5703

SCALE .250 REF. *** SHEET 1 OF 2 REV REV DESC DATE

E	EN-3558a	1/2/2019
D	EN-2160A	09/21/12
C	EN-2111	05/03/12
B	EN-2049	01/18/12
A	EN-1552-4 A	09/15/11
-	EN-1552	3/14/11

SPECIFICATION DWG

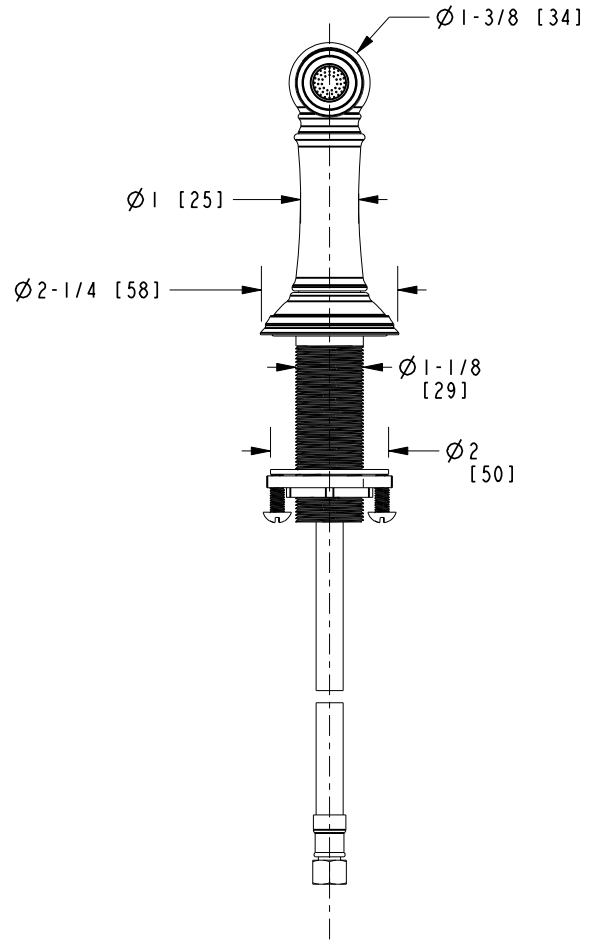
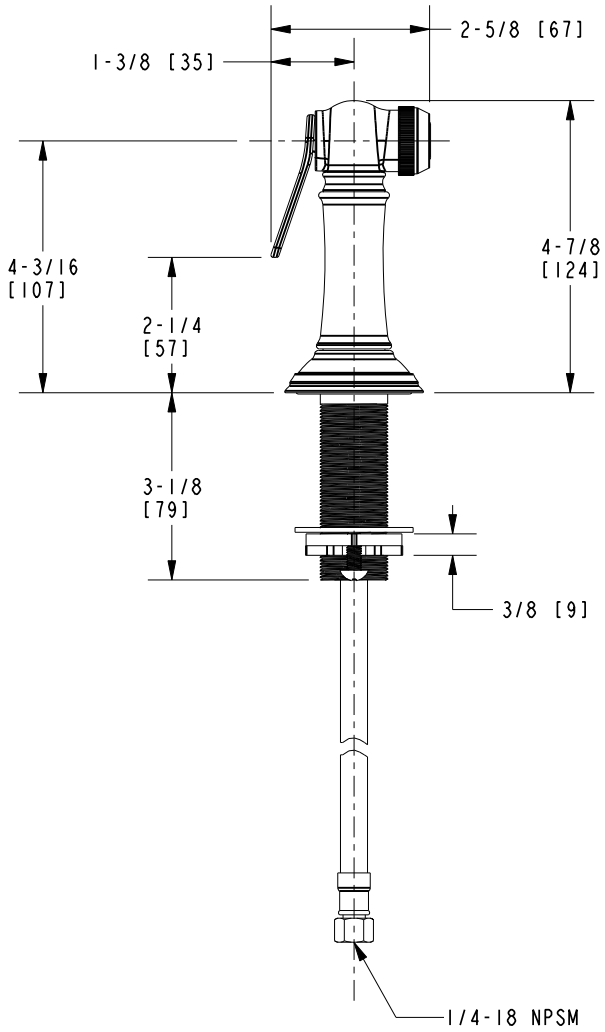

DIMENSIONS ARE IN INCHES AND AN APPROXIMATION OF A TYPICAL INSTALLATION

COPYRIGHT 2005 BRASSTECH, INC. THESE DRAWINGS AND THE DESIGNS DEPICTED HEREIN ARE THE PROPRIETARY PROPERTY OF BRASSTECH. ANY USE OR REPRODUCTION IS SUBJECT TO THE EXPRESS APPROVAL OF BRASSTECH. UNAUTHORIZED USE IS STRICTLY PROHIBITED. ALL RIGHTS RESERVED.

BRASSTECH		2001 CARNEGIE AVE. SANTA ANA, CA 92705 (949) 417-5207	
INCORPORATED			
DWG NO.	2470-5703		REV E
SCALE .312	REF. ***	SHEET 2 OF 2	