

NOTES:

1. TO INSPECT ASSEMBLY, FOLLOW FIRST ARTICLE AND IN PROCESS INSPECTION SHEET.

BILL OF MATERIAL (CURRENT LEVEL)

ITEM	PT/ASSY	DESCRIPTION	TYPE	QTY.
1	5084SO	24" GRAB BAR BRAZE ASM	ASSEMBLY	1
2	1995	MOUNTING FLANGE	PART	2
3	199X	GRAB BAR MOUNTING HARDWARE PACK	ASSEMBLY	2
4	4672	GRAB BAR ROSETTE	PART	2

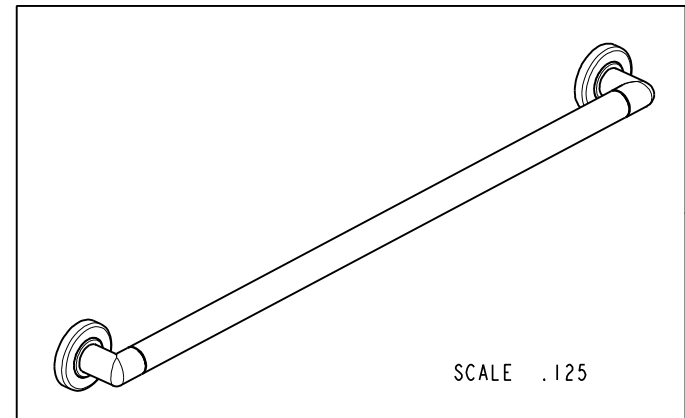
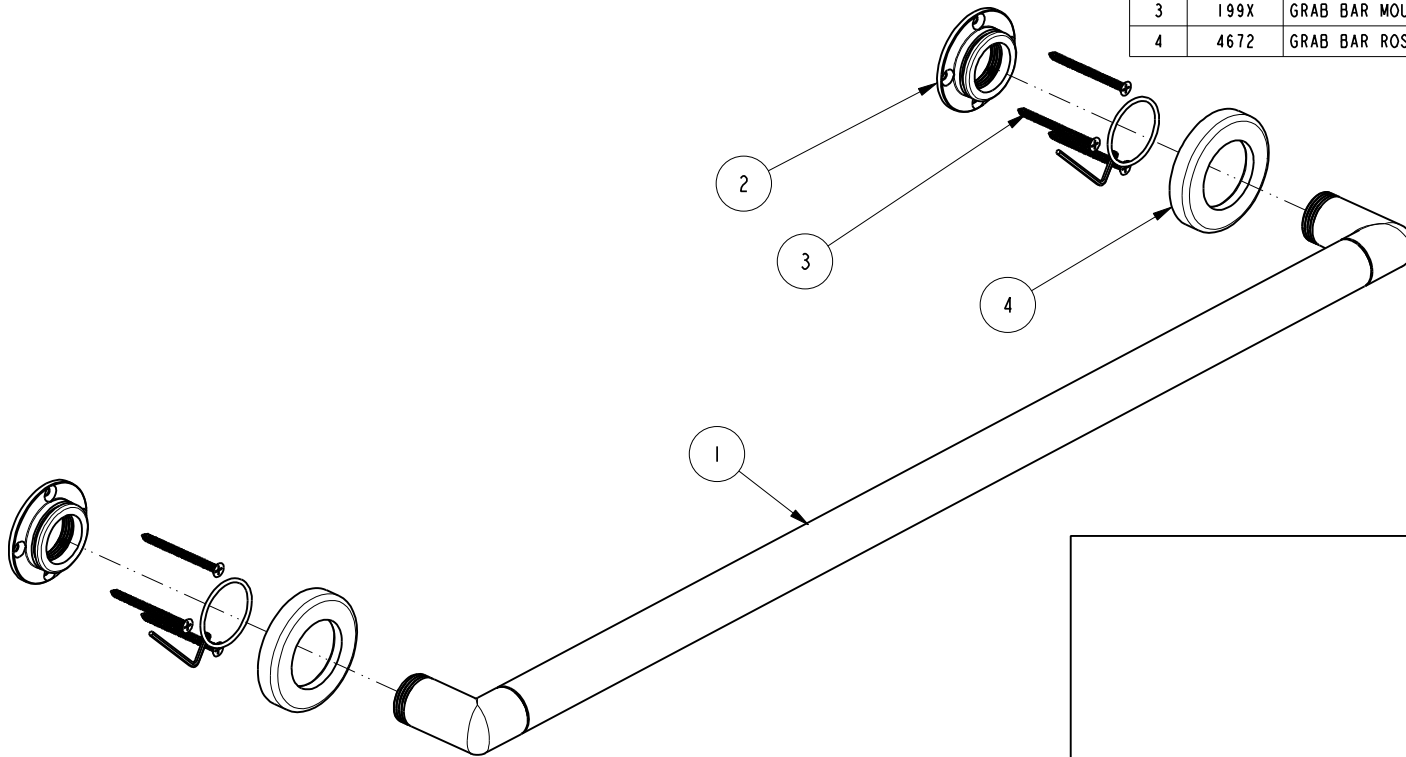

UNITS ARE: INCHES [MM]
 TOLERANCES ARE:
 FRACTIONS DECIMALS ANGLES
 ±1/16" .X ±.1 [2.5] ±1°
 .XX ±.06 [1.5]

(X.XXX) DENOTES CRITICAL DIMS.
 ALL THREADS ARE CRITICAL

BRASSTECH 2001 CARNEGIE AVE.
 INCORPORATED SANTA ANA, CA 92705
 (949) 417-5207

GRAB BAR 32"

ZONE	REV	DESCRIPTION	DATE	APPROVED
-	B	EN-4300i	06/22/21	R.S.
-	A	EN-4143	03/20/20	J.M.
-	-	EN-3279b	04/17/17	J.M.

COPYRIGHT 2005 BRASSTECH, INC.
 THESE DRAWINGS AND THE DESIGNS
 DEPICTED HEREIN ARE THE PROPRIETARY
 PROPERTY OF BRASSTECH. ANY USE
 OR REPRODUCTION IS SUBJECT TO
 THE EXPRESS APPROVAL OF BRASSTECH.
 UNAUTHORIZED USE IS STRICTLY
 PROHIBITED. ALL RIGHTS RESERVED.

TESTING	ASSEMBLY	PLATING	POLISHING	MACHINING	TOOLING FIXTURE #	APPLICATION
-	-	-	-	-	-	-
-	-	-	-	-	-	-
-	-	-	NEXT ASSY	USED ON	-	-
-	-	-	-	-	-	REMOVE ALL BURRS AND SHARP EDGES

DRAWN	CHECKED	APPROVED
JINSON	R.S.	R.S.
06/22/21	06/22/21	06/22/21

DWG NO.	SCALE	REF.	SHEET	OF
2480-3932	.218	-	1	2

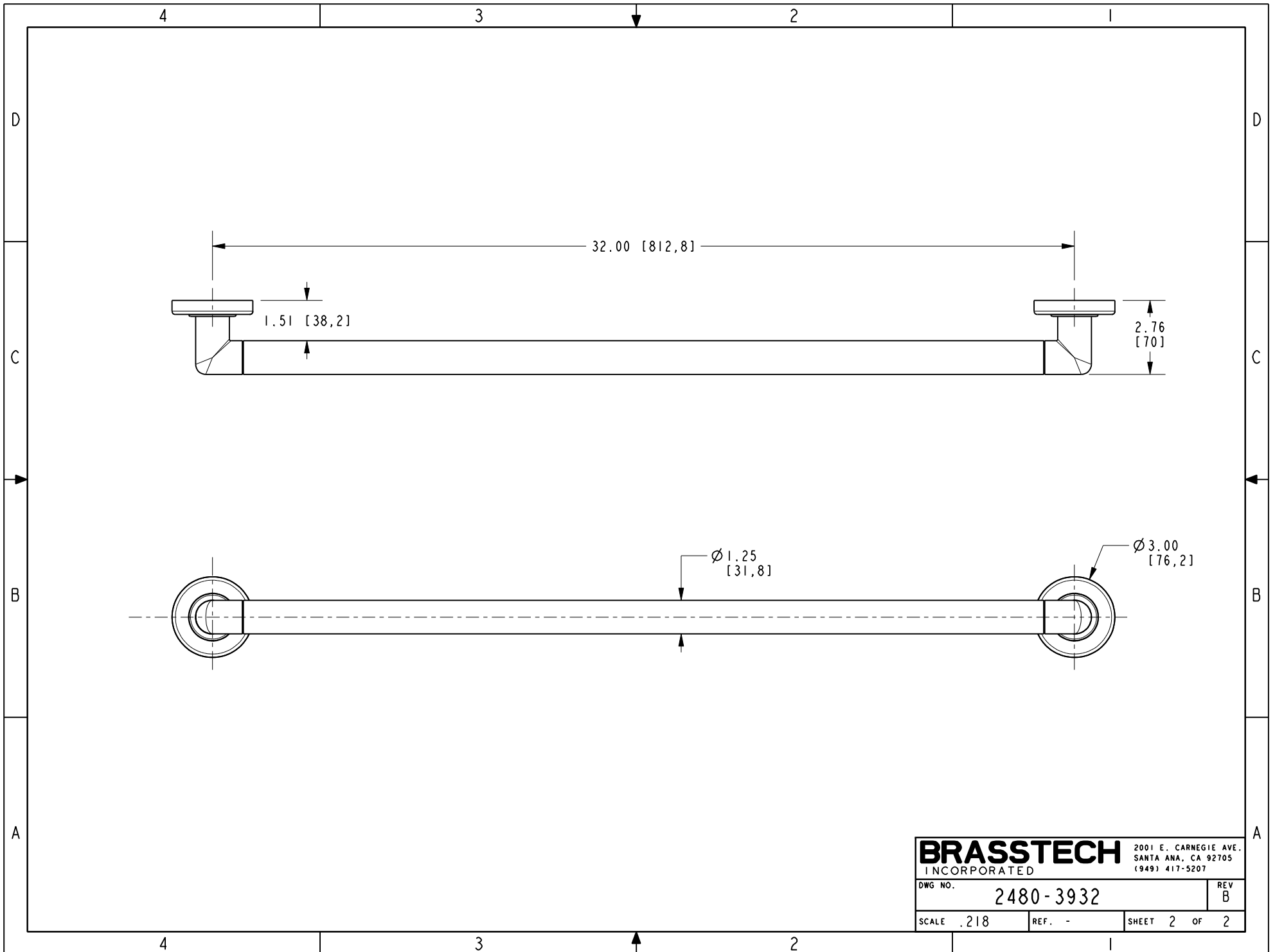

BRASSTECH		2001 E. CARNEGIE AVE. SANTA ANA, CA 92705 (949) 417-5207
DWG NO.	2480-3932	REV B
SCALE .218	REF. -	SHEET 2 OF 2