

NOTES:

1. TO INSPECT ASSEMBLY, FOLLOW FIRST ARTICLE AND IN PROCESS INSPECTION SHEET.

BILL OF MATERIAL (CURRENT LEVEL)

ITEM	PT/ASSY	DESCRIPTION	TYPE	QTY.
1	40799	8" BACKPLATE	PART	1
2	7-758	BRAZED TOWEL RING ASM.	ASSEMBLY	1
3	92031	SCRW, M6 X 1 X 6 SKT HD CUP PT W/ SELF LOC SS	PART	2
4	28XXG	MOUNTING BRACKET	PART	2
5	1-206	HARDWARE PACK	ASSEMBLY	2
6	10615	HEX KEY, 3MM ALLOY STEEL	PART	1

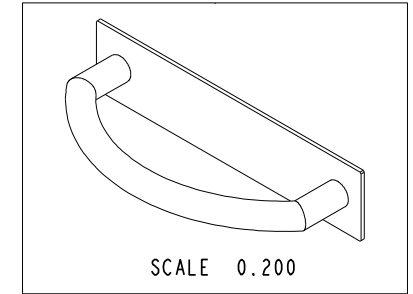
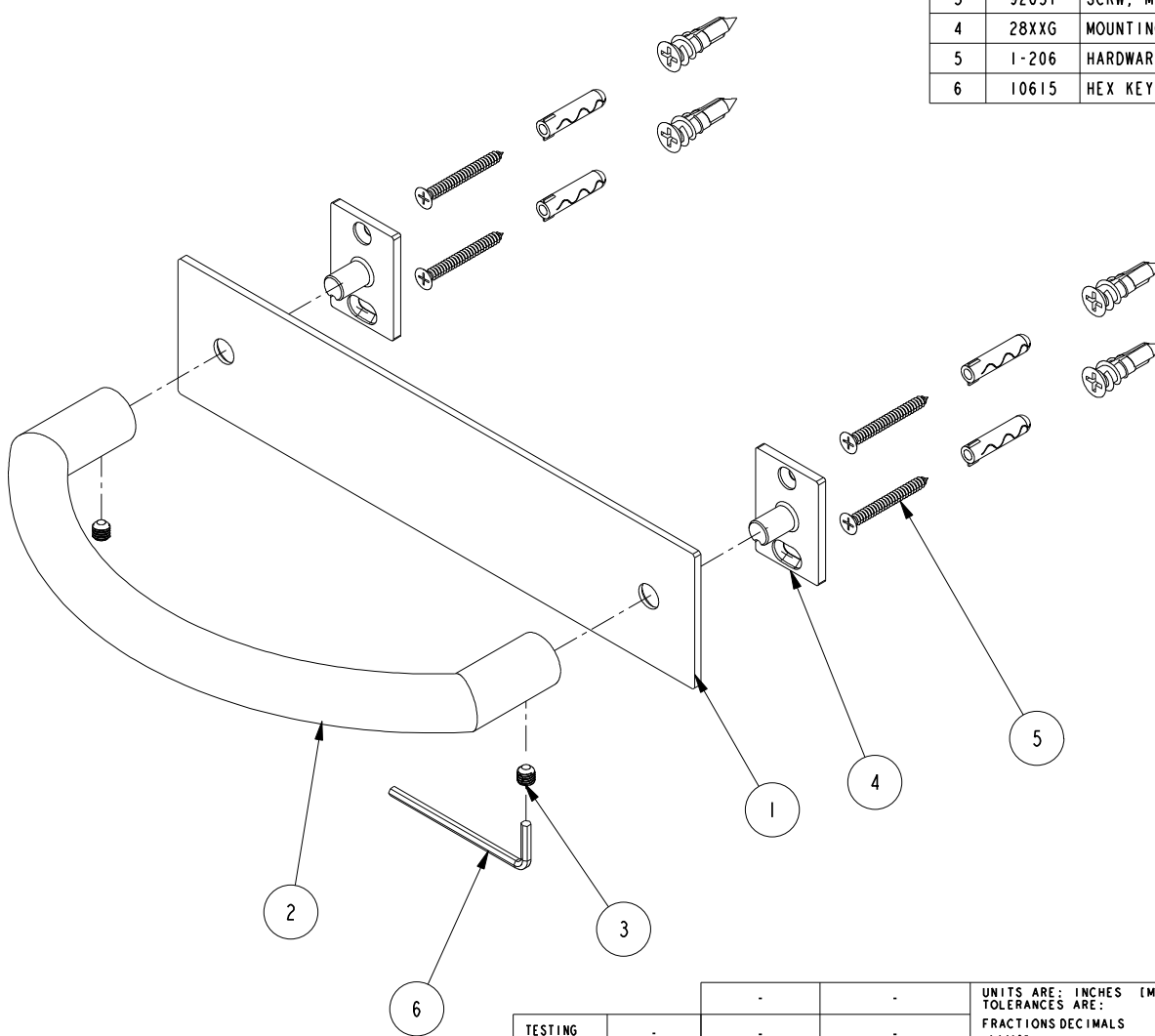

ZONE	REV	DESCRIPTION	DATE	APPROVED
-	C	EN-4430	01/28/22	R. S.
-	B	EN-4069	01/23/20	J. M.
-	A	EN-4022	11/11/19	J. M.
-	-	EN-3912	07/26/19	J. M.

COPYRIGHT 2005 BRASSTECH, INC. THESE DRAWINGS AND THE DESIGNS DEPICTED HEREIN ARE THE PROPRIETARY PROPERTY OF BRASSTECH. ANY USE OR REPRODUCTION IS SUBJECT TO THE EXPRESS APPROVAL OF BRASSTECH. UNAUTHORIZED USE IS STRICTLY PROHIBITED. ALL RIGHTS RESERVED.

TESTING	-	-	-
ASSEMBLY	-	-	-
PLATING	-	-	-
POLISHING	-	NEXT ASSY	USED ON
MACHINING	-	APPLICATION	
TOOLING FIXTURE #	REMOVE ALL BURRS AND SHARP EDGES		

UNITS ARE: INCHES [MM]
TOLERANCES ARE:
FRACTIONS DECIMALS ANGLES
±1/16" .X ±.1 [2.5] ±1°
.XX ±.06 [1.5]

(X.XXX) DENOTES CRITICAL DIMS.
ALL THREADS ARE CRITICAL

DRAWN	G.B.	07/26/19
CHECKED	J.M.	07/26/19
APPROVED	J.M.	07/26/19

BRASSTECH
INCORPORATED

2001 CARNEGIE AVE.
SANTA ANA, CA 92705
(949) 417-5207

TOWEL RING

DWG NO.	2540-1410	REV	C
SCALE	0.400	REF.	-
SHEET	1	OF	2

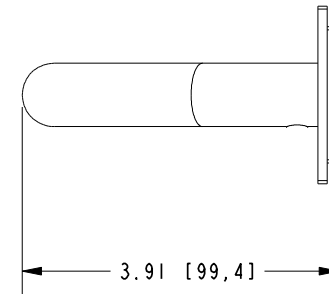
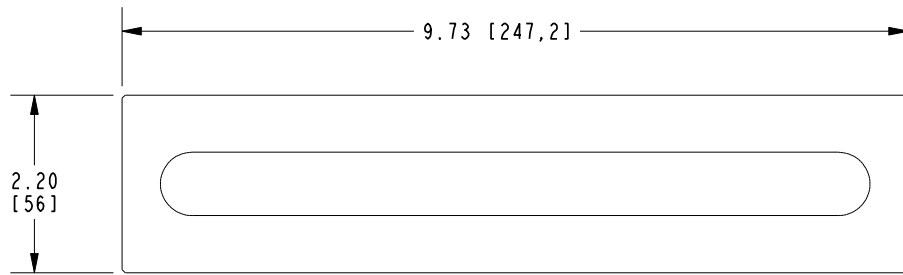
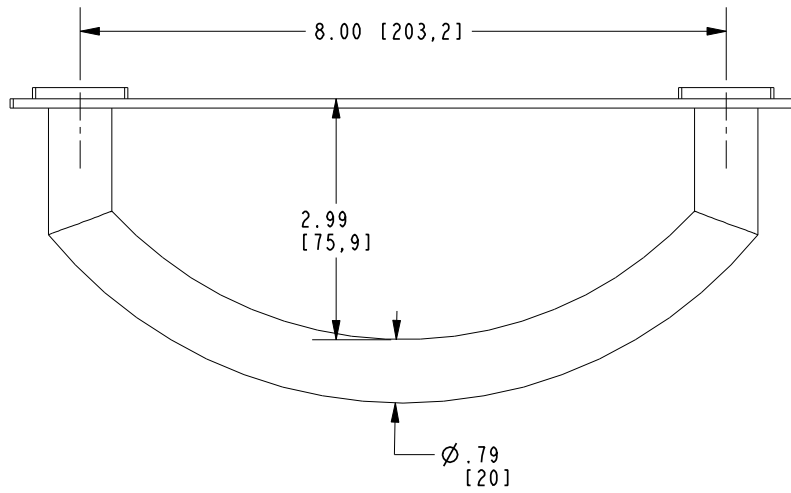

BRASSTECH		2001 E. CARNEGIE AVE. SANTA ANA, CA 92705 (949) 417-5207	
DWG NO.	2540-1410	REV	C
SCALE	0.420	REF.	-
		SHEET	2 OF 2