

NOTES:

1. TO INSPECT ASSEMBLY, FOLLOW FIRST ARTICLE AND IN PROCESS INSPECTION SHEET.

2. APPLY LOCTITE 680 TO THREADS

BILL OF MATERIAL (CURRENT LEVEL)

ITEM	PT/ASSY	DESCRIPTION	TYPE	QTY.
1	40801	HOOK BACKPLATE	PART	1
2	40802	TISSUE HOLDER POST	PART	1
3	40789	POST FINAL	PART	1
4	28XXG	MOUNTING BRACKET	PART	1
5	1-206	HARDWARE PACK	ASSEMBLY	1
6	92031	SCRW, M6 X 1 X 6 SKT HD CUP PT W/ SELF LOC SS	PART	1
7	10615	HEX KEY, 3MM ALLOY STEEL	PART	1

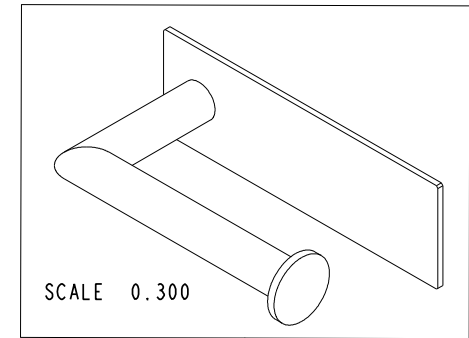
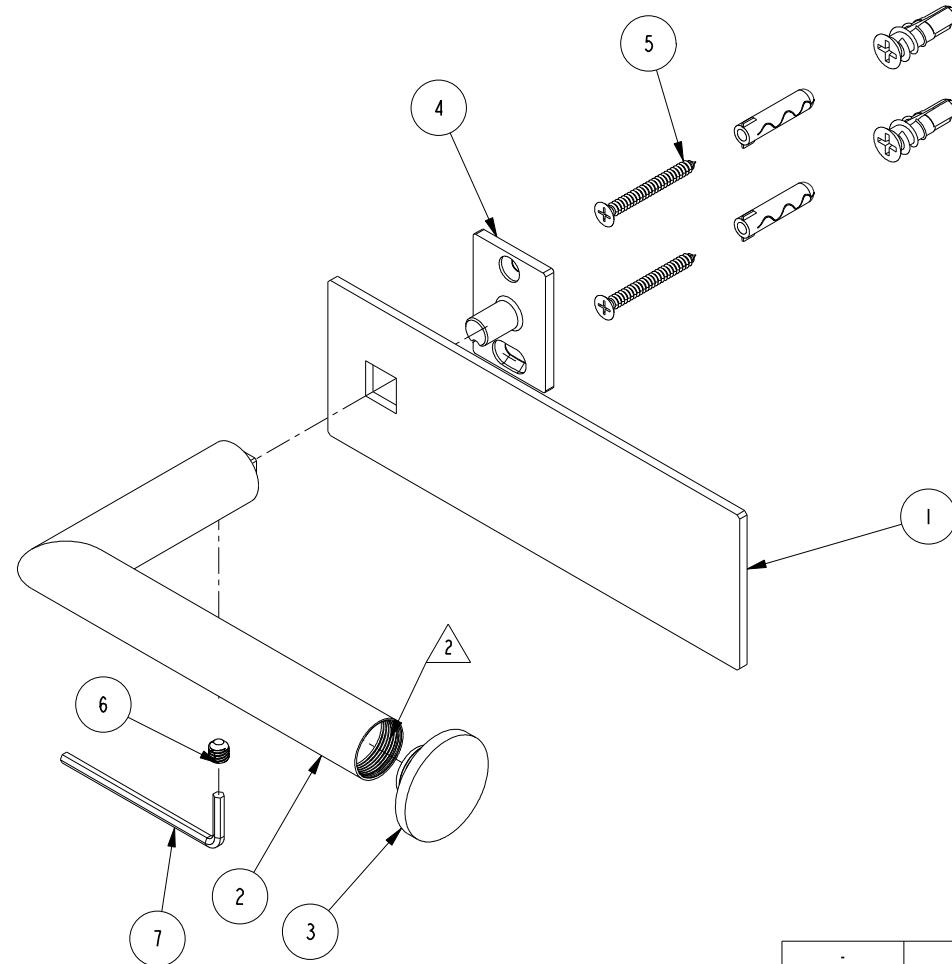

ZONE	REV	DESCRIPTION	DATE	APPROVED
-	C	EN-4430	01/28/22	R. S.
-	B	EN-4069	01/23/20	J. M.
-	A	EN-4022	11/12/19	J. M.
-	-	EN-3912	08/02/19	J. M.

COPYRIGHT 2005 BRASSTECH, INC. THESE DRAWINGS AND THE DESIGNS DEPICTED HEREIN ARE THE PROPRIETARY PROPERTY OF BRASSTECH. ANY USE OR REPRODUCTION IS SUBJECT TO THE EXPRESS APPROVAL OF BRASSTECH. UNAUTHORIZED USE IS STRICTLY PROHIBITED. ALL RIGHTS RESERVED.

TESTING	-	-	-
ASSEMBLY	-	-	-
PLATING	-	-	-
POLISHING	-	NEXT ASSY	USED ON
MACHINING	-	APPLICATION	
TOOLING FIXTURE #	REMOVE ALL BURRS AND SHARP EDGES		

UNITS ARE: INCHES [MM]			
TOLERANCES ARE:			
FRACTIONS	DECIMALS	ANGLES	
±1/16"	.X ±.1 [2.5]	±1°	
	.XX ±.06 [1.5]		
(X.XXX) DENOTES CRITICAL DIMS.			
ALL THREADS ARE CRITICAL			
DRAWN	G.B.	08/02/19	
CHECKED	J.M.	08/02/19	
APPROVED	J.M.	08/02/19	

BRASSTECH 2001 CARNEGIE AVE. SANTA ANA, CA 92705 (949) 417-5207
INCORPORATED

TP HOLDER - OPEN

DWG NO. 2540-1570 REV C

SCALE 0.450 REF. - SHEET 1 OF 2

