

NOTES:

(NI) 1. FIT / FORM / FUNCTION SHALL FOLLOW PS-E.008.

2. APPLY LOCTITE 680.

BILL OF MATERIAL (CURRENT LEVEL)

ITEM	PT/ASSY	DESCRIPTION	TYPE	QTY.
1	50296	BODY	PART	1
2	92070	SCRW, #14 X 2 SLT FLT HD SS	PART	1
3	50300	SPRING - 5/8"	PART	1
4	50299	COLLAR NUT	PART	1
5	50298	PIVOT BALL	PART	1
6	50301	WSHR, .683 OD X .019 THK, FLARED, STEEL	PART	1
7	13365	HOLDER - HANDSHOWER	PART	1
8	91368	WALL ANCHOR PLASTIC, 12-1/4	PART	1
9	91157	WSHR, .920 ID X 1.0 OD X .066 THK, FLT, NYLON	PART	1

ZONE	REV	DESCRIPTION	DATE	APPROVED
-	F	EN-4031	12/02/19	J.M.
-	E	EN-3817	02/26/19	NS
-	D	EN-2462b	02/07/14	AN
-	C	EN-2456	04/04/13	JM
-	B	EN-2142	04/23/12	JM
-	A	EO-0093	01/17/03	-
-	-	RELEASED	01/08/02	-

COPYRIGHT 2005 BRASSTECH, INC. THESE DRAWINGS AND THE DESIGNS DEPICTED HEREIN ARE THE PROPRIETARY PROPERTY OF BRASSTECH. ANY USE OR REPRODUCTION IS SUBJECT TO THE EXPRESS APPROVAL OF BRASSTECH. UNAUTHORIZED USE IS STRICTLY PROHIBITED. ALL RIGHTS RESERVED.

TESTING	ASSEMBLY	PLATING	POLISHING	MACHINING	TOOLING FIXTURE #
-	-	-	-	-	-
-	-	-	-	-	-
-	-	-	-	-	-
-	-	-	-	-	-
-	-	-	-	-	-
-	-	-	-	-	-
-	-	-	-	-	-

UNITS ARE:	TOLERANCES ARE:
INCHES [MM]	FRACTIONS DECIMALS ANGLES
	±1/16" .X ±.1 [2.5] ±1°
	.XX ±.06 [1.5]
(X.XXX) DENOTES CRITICAL DIMS. ALL THREADS ARE CRITICAL	
DRAWN	HUNG LE 01/07/02
CHECKED	JW 01/08/02
APPROVED	JW 01/08/02

BRASSTECH 2001 CARNEGIE AVE. SANTA ANA, CA 92705 (949) 417-5207
 INCORPORATED

COMPL. BRACKET - HANDSHOWER

DWG NO. **287** REV **F**

SCALE .500 REF. - SHEET 1 OF 2

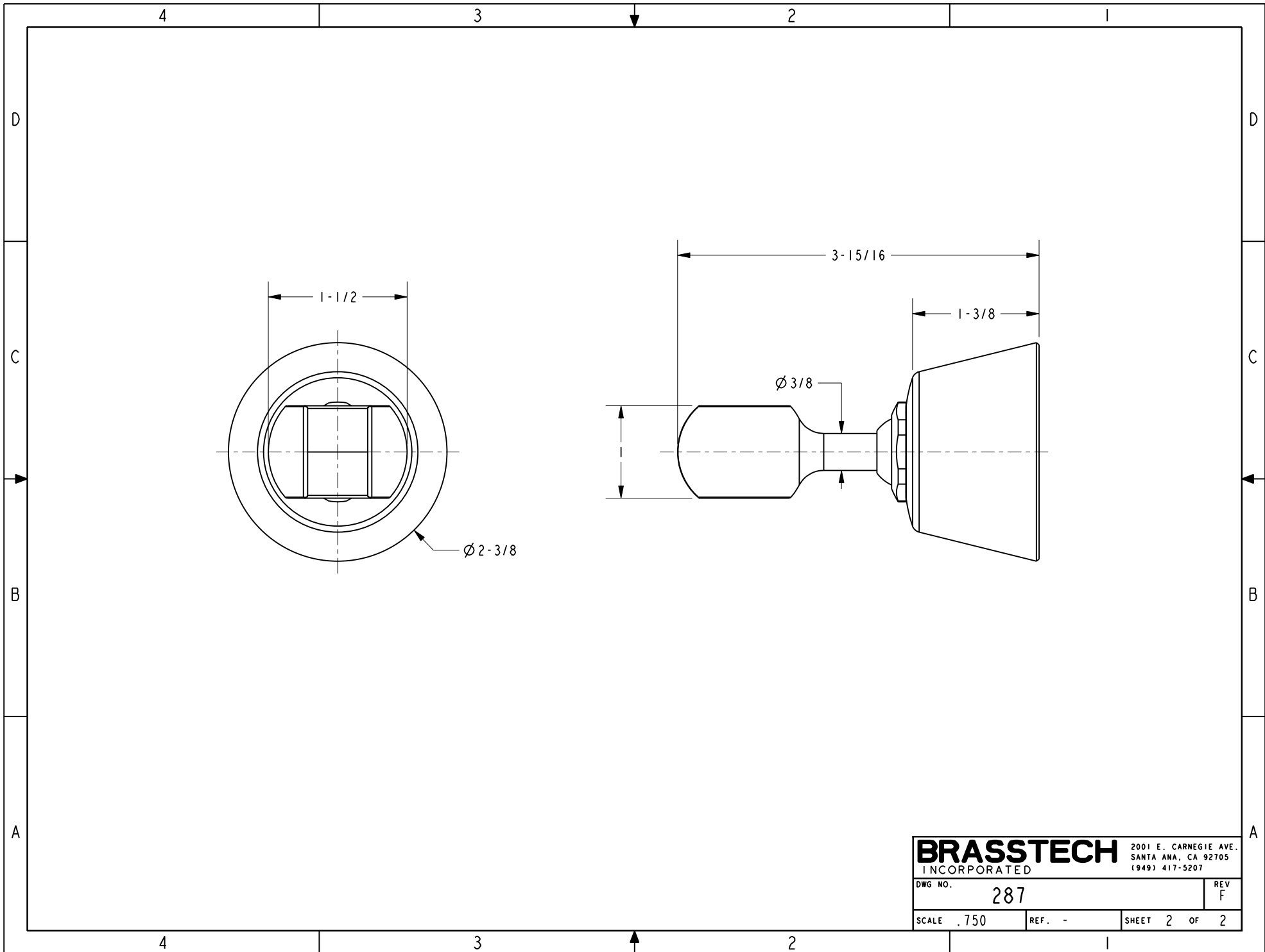

BRASSTECH		2001 E. CARNEGIE AVE.	
INCORPORATED		SANTA ANA, CA 92705	
DWG NO. 287		REV F	
SCALE .750	REF. -	SHEET 2 OF 2	