

NOTES:

1. TO INSPECT ASSEMBLY, FOLLOW FIRST ARTICLE AND IN PROCESS INSPECTION SHEET.

**BILL OF MATERIAL (CURRENT LEVEL)**

ITEM	PT/ASSY	DESCRIPTION	TYPE	QTY.
1	1-525	W/S VALVE ASM	ASSEMBLY	1
2	3-233	W/S SPOUT ASM	ASSEMBLY	1
3	3-570	HANDLE/ ESC ASM	ASSEMBLY	2
4	325	POP UP ASSEMBLY	ASSEMBLY	1
5	10288	3/16" POP UP ROD	PART	1
6	10827	POP-UP KNOB	PART	1

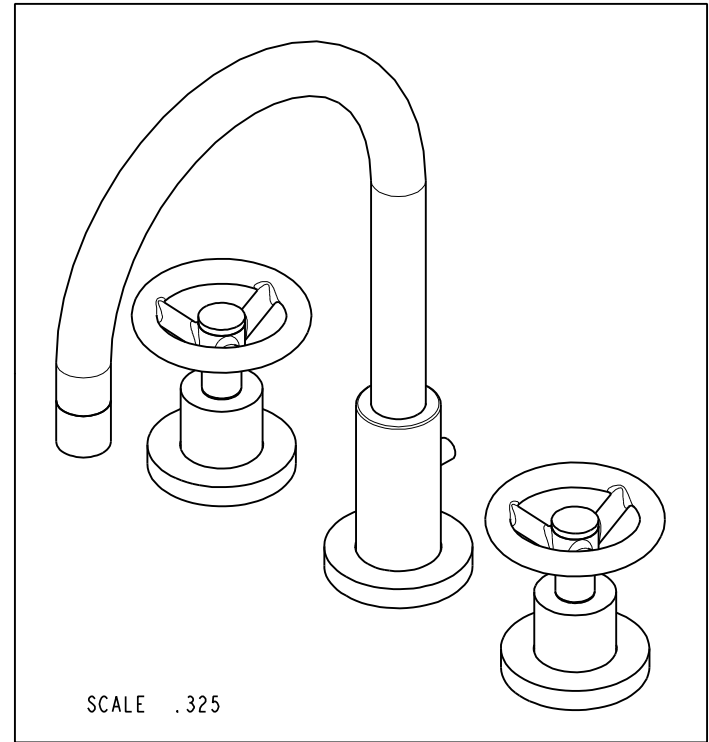
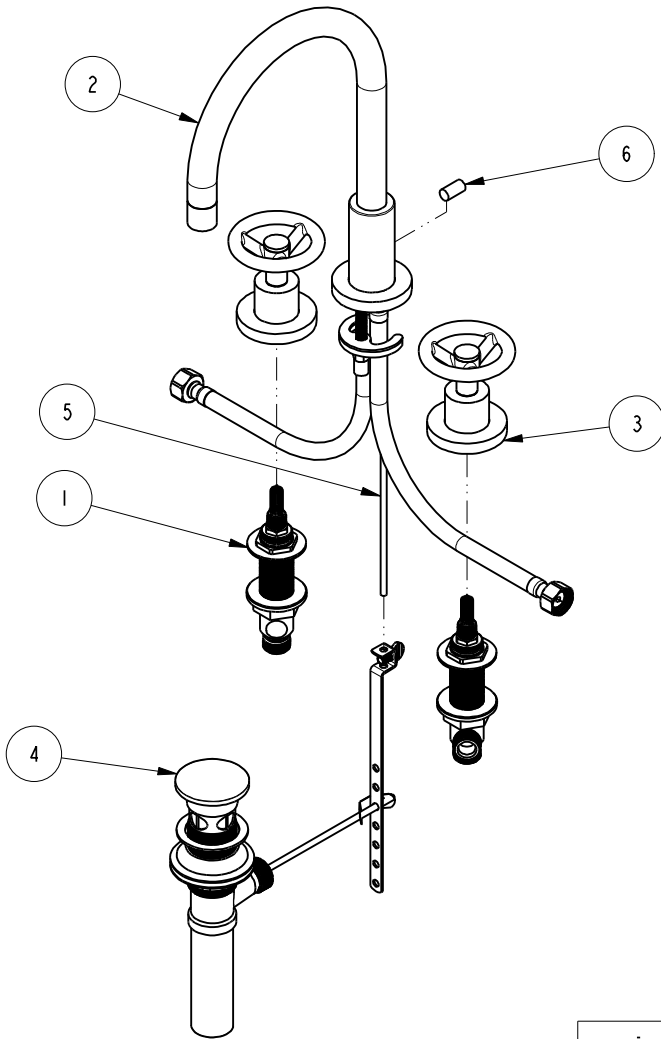

ZONE	REV	DESCRIPTION	DATE	APPROVED
-	B	EN-4300m	11/05/20	R.S.
-	A	EN-3242	01/27/17	AN
-	-	EN-3005b	03/21/16	AN

COPYRIGHT 2005 BRASSTECH, INC. THESE DRAWINGS AND THE DESIGNS DEPICTED HEREIN ARE THE PROPRIETARY PROPERTY OF BRASSTECH. ANY USE OR REPRODUCTION IS SUBJECT TO THE EXPRESS APPROVAL OF BRASSTECH. UNAUTHORIZED USE IS STRICTLY PROHIBITED. ALL RIGHTS RESERVED.

TESTING	-	-	-
ASSEMBLY	-	-	-
PLATING	-	-	-
POLISHING	-	NEXT ASSY	USED ON
MACHINING	-	APPLICATION	
TOOLING FIXTURE #	REMOVE ALL BURRS AND SHARP EDGES		

UNITS ARE: INCHES [MM]		
TOLERANCES ARE:		
FRACTIONS DECIMALS	ANGLES	
±1/16"	.X ±.1 [2,5]	±1°
	.XX ±.06 [1,5]	
(X.XXX) DENOTES CRITICAL DIMS. ALL THREADS ARE CRITICAL		
DRAWN	JINSON	11/05/20
CHECKED	R.S.	11/05/20
APPROVED	R.S.	11/05/20

**BRASSTECH** 2001 CARNEGIE AVE. SANTA ANA, CA 92705 (949) 417-5207  
INCORPORATED

**W/S LAV FAUCET**

DWG NO. **2920** REV **B**

SCALE .175 REF. - SHEET 1 OF 2

