

NOTES:

1. TO INSPECT ASSEMBLY, FOLLOW FIRST ARTICLE AND IN PROCESS INSPECTION SHEET.

BILL OF MATERIAL (CURRENT LEVEL)

ITEM	PT/ASSY	DESCRIPTION	TYPE	QTY.
1	1-676	W/S VALVE INSTALLATION	ASSEMBLY	1
2	3-574	W/S SPOUT ASSEMBLY	ASSEMBLY	1
3	3-573	HANDLE AND ESCUTCHEON ASSEMBLY	ASSEMBLY	2
4	325	POP UP ASSEMBLY	ASSEMBLY	1
5	91571	AERATOR KEY	PART	1

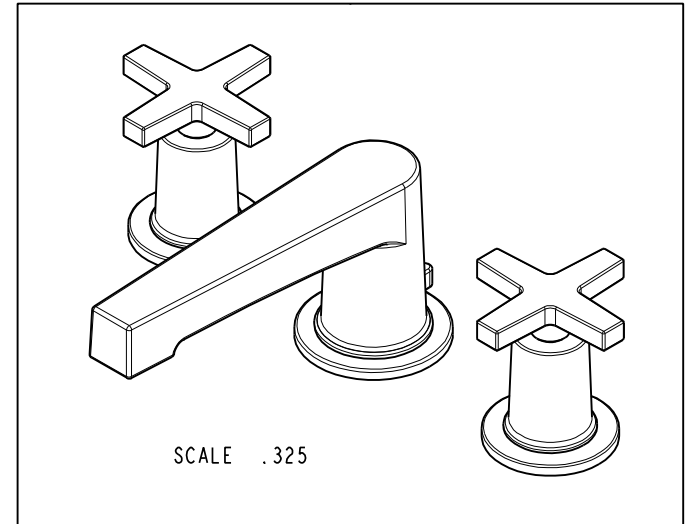
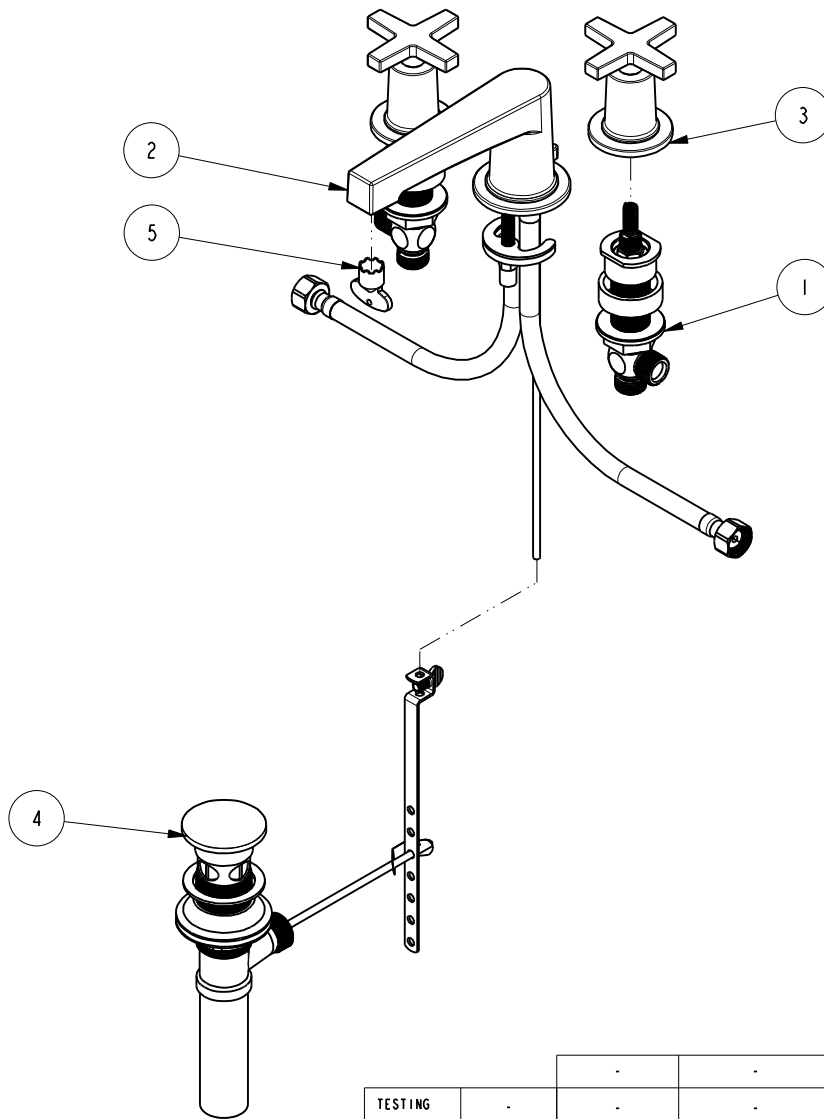

ZONE	REV	DESCRIPTION	DATE	APPROVED
-	C	EN-4300m	11/06/20	R.S.
-	B	EN-3601	05/07/18	V.V.
-	A	EN-3189	11/09/16	J.M.
-	-	EN-3041	07/27/16	J.M.

COPYRIGHT 2005 BRASSTECH, INC. THESE DRAWINGS AND THE DESIGNS DEPICTED HEREIN ARE THE PROPRIETARY PROPERTY OF BRASSTECH. ANY USE OR REPRODUCTION IS SUBJECT TO THE EXPRESS APPROVAL OF BRASSTECH. UNAUTHORIZED USE IS STRICTLY PROHIBITED. ALL RIGHTS RESERVED.

TESTING	-	-	-
ASSEMBLY	-	-	-
PLATING	-	-	-
POLISHING	-	NEXT ASSY	USED ON
MACHINING	-	APPLICATION	
TOOLING FIXTURE #	REMOVE ALL BURRS AND SHARP EDGES		

UNITS ARE: INCHES [MM]  
 TOLERANCES ARE:  
 FRACTIONS DECIMALS ANGLES  
 $\pm 1/16"$  .X  $\pm .1$  [2,5]  $\pm 1^\circ$   
 .XX  $\pm .06$  [1,5]  
 (X.XXX) DENOTES CRITICAL DIMS.  
 ALL THREADS ARE CRITICAL  
 DRAWN JINSON 11/06/20  
 CHECKED R.S. 11/06/20  
 APPROVED R.S. 11/06/20

**BRASSTECH** 2001 CARNEGIE AVE.  
 INCORPORATED SANTA ANA, CA 92705  
 (949) 417-5207

**WIDESPREAD LAVATORY FAUCET**

DWG NO. **2980** REV **C**

SCALE .200 REF. - SHEET 1 OF 2

