

REPLACEMENT PARTS

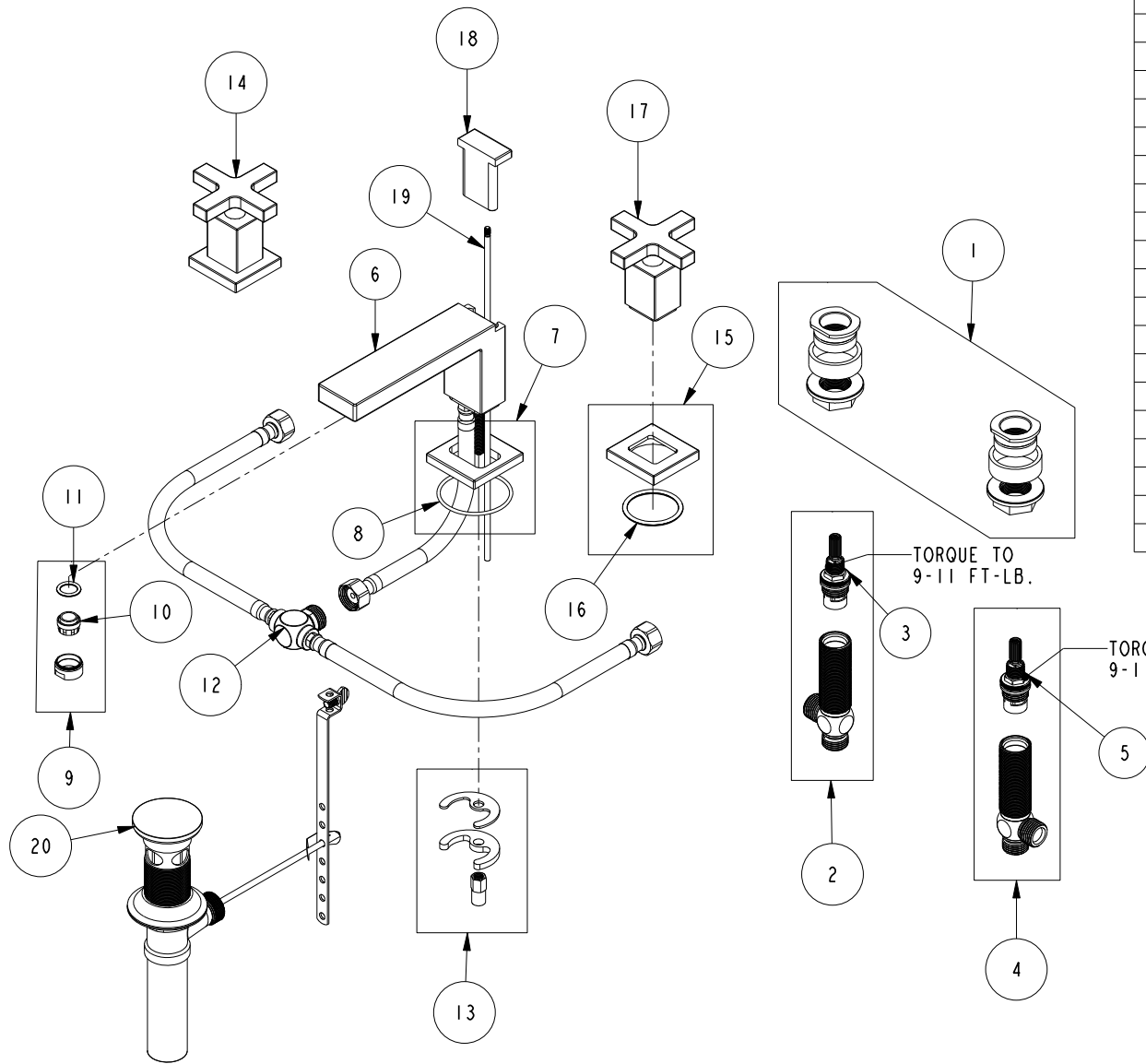

ITEM	PT/ASSY	SPECIFY FINISH	DESCRIPTION
1	1-226		WIDESPREAD MOUNTING HARDWARE
2	1-527		W/S CART/BODY ASM (HOT)
3	1-002		W/S CARTRIDGE - HOT
4	1-526		W/S CART/BODY ASM (COLD)
5	1-001		W/S CARTRIDGE - COLD
6	3-436	YES	SPOUT ASM
7	8-024	YES	WIDESPREAD SPOUT BASE ASM
8	91751		O-RING, #2-139, 50 DURO
9	8-176	YES	AERATOR ASM, 1.2 GPM
10	12403		AERATOR INSERT, Jr. SIZE, 1.2 GPM
11	91028		O-RING, #2-113, EPDM, 65-75 DURO, NSF 61
12	1-655		WATER MIXER WIDESPREAD
13	1-491		SPOUT MOUNTING KIT
14	3-577	YES	HANDLE CROSS/ ESC ASM
15	2-936	YES	HANDLE ESCUTCHEON ASM
16	91748		O-RING, #2-223, EP, 50 DURO - GREY
17	20-175	YES	HANDLE CROSS ASM
18	80030	YES	POP UP KNOB
19	10288	YES	3/16" POP UP ROD
20	325	YES	POP UP ASSEMBLY

W/S LAV FAUCET
2990

REV E EN-4877 09/05/24

NEWPORT BRASS.

t: 949.417.5207 | www.newportbrass.com