

4

3

2

1

NOTES:

(NI) 1. FIT / FORM / FUNCTION SHALL FOLLOW PS-E.008.

BILL OF MATERIAL (CURRENT LEVEL)

ITEM	PT/ASSY	DESCRIPTION	TYPE	QTY.
1	2-994	TUB AND SHOWER PLATE ASM	ASSEMBLY	1
2	2-989	COLLAR ASM	ASSEMBLY	1
3	91308	TEMP LIMIT STOP - THERMO	PART	1
4	12344	HANDLE BONNET	PART	1
5	12345	SLEEVE - THERMO	PART	1
6	2-991	THERMO BONNET ASM	ASSEMBLY	1
7	92113	SCRW, M4 X .7 X 40 PHL FLT HD SS	PART	2
8	2-273	THERMO HANDLE ASM	ASSEMBLY	1
9	2-443	CROSS HANDLE ASM	ASSEMBLY	1
10	1-110	BUTTON W/ADHESIVE	ASSEMBLY	1

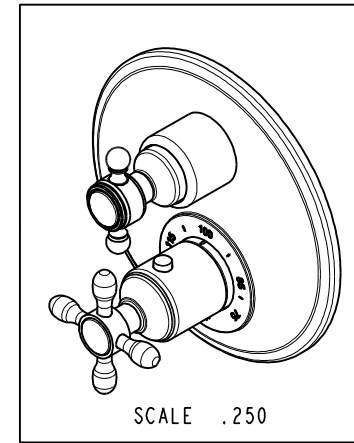
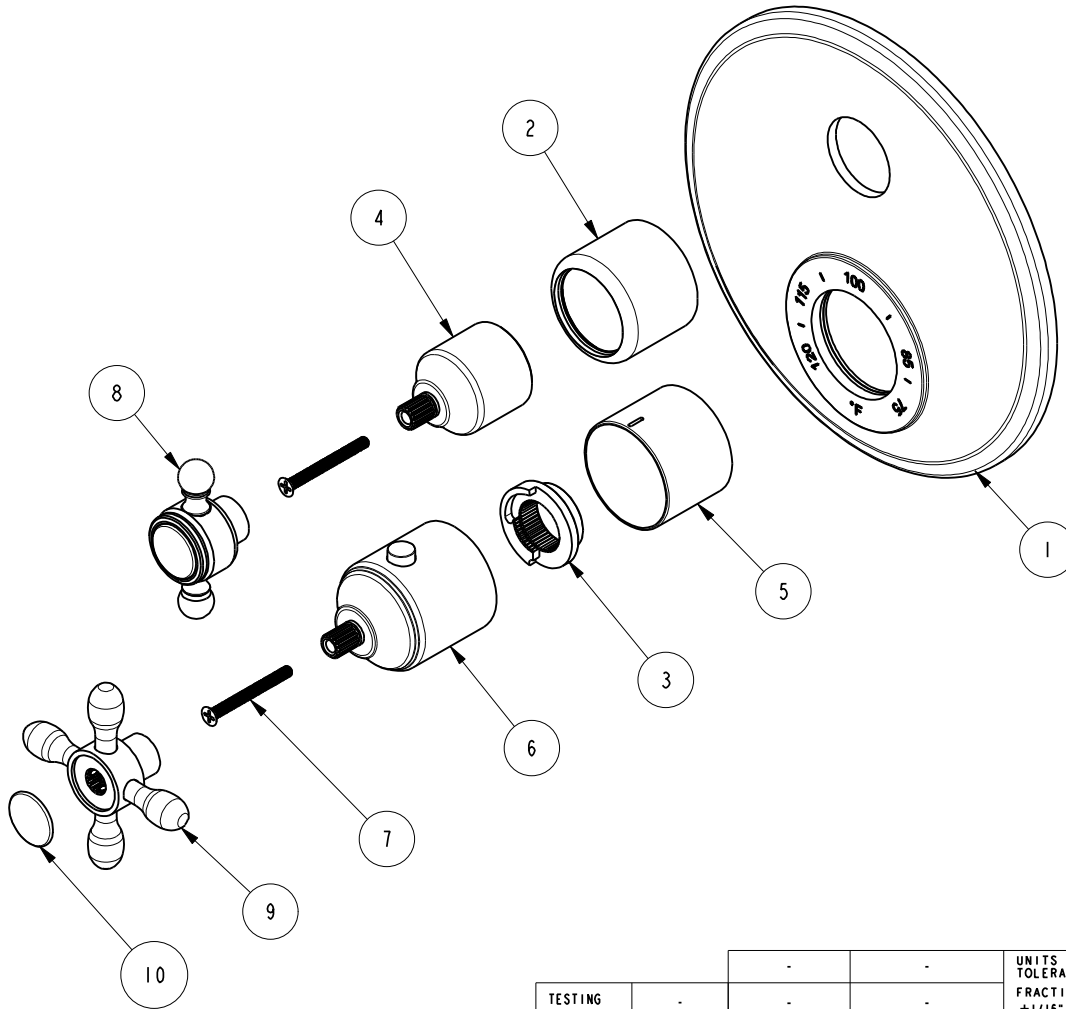

D

D

C

C

B

B

A

A

UNITS ARE: INCHES [MM]
 TOLERANCES ARE:
 FRACTIONS DECIMALS ANGLES
 $\pm 1/16"$.X $\pm .1$ [2,5] $\pm 1^\circ$
 .XX $\pm .06$ [1,5]
 (X.XXX) DENOTES CRITICAL DIMS.
 ALL THREADS ARE CRITICAL

BRASSTECH 2001 CARNEGIE AVE.
 INCORPORATED SANTA ANA, CA 92705
 (949) 417-5207

THERMO TUB / SHOWER

ZONE	REV	DESCRIPTION	DATE	APPROVED
-	A	EN-3236	01/17/17	R.S.
-	-	EN-2775h	11/20/15	J.M.

COPYRIGHT 2005 BRASSTECH, INC.
 THESE DRAWINGS AND THE DESIGNS
 DEPICTED HEREIN ARE THE PROPRIETARY
 PROPERTY OF BRASSTECH. ANY USE
 OR REPRODUCTION IS SUBJECT TO
 THE EXPRESS APPROVAL OF BRASSTECH.
 UNAUTHORIZED USE IS STRICTLY
 PROHIBITED. ALL RIGHTS RESERVED.

TESTING	-	-	-
ASSEMBLY	-	-	-
PLATING	-	-	-
POLISHING	-	NEXT ASSY	USED ON
MACHINING	-	APPLICATION	
TOOLING FIXTURE #	REMOVE ALL BURRS AND SHARP EDGES		

DRAWN	JINSON	01/17/17
CHECKED	RAVINDRA	01/17/17
APPROVED	R.S.	01/17/17

DWG NO.	3-1643TR		REV	A
SCALE	.375	REF.	-	SHEET 1 OF 2

4

3

2

1

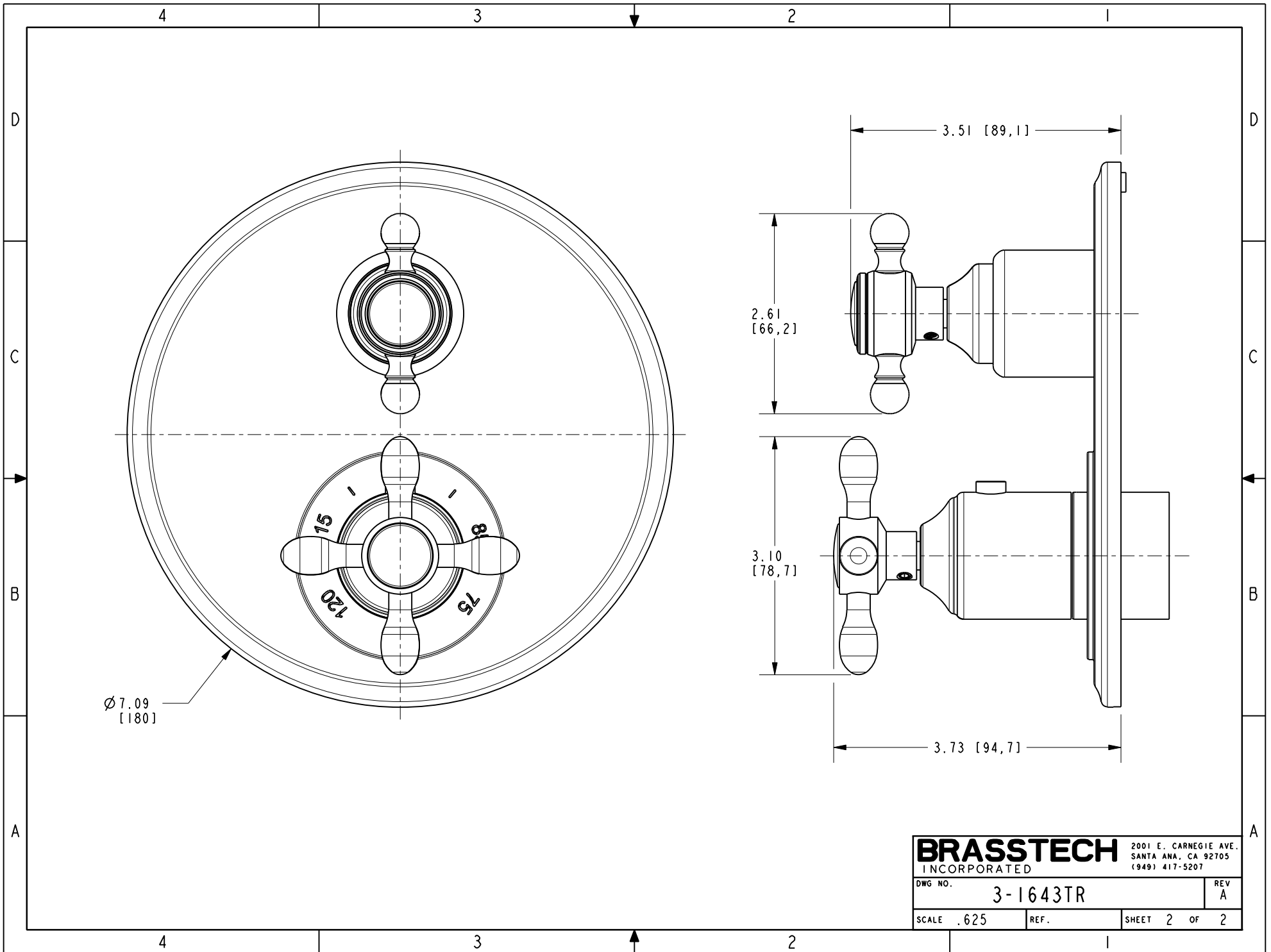

Ø 7.09
[180]

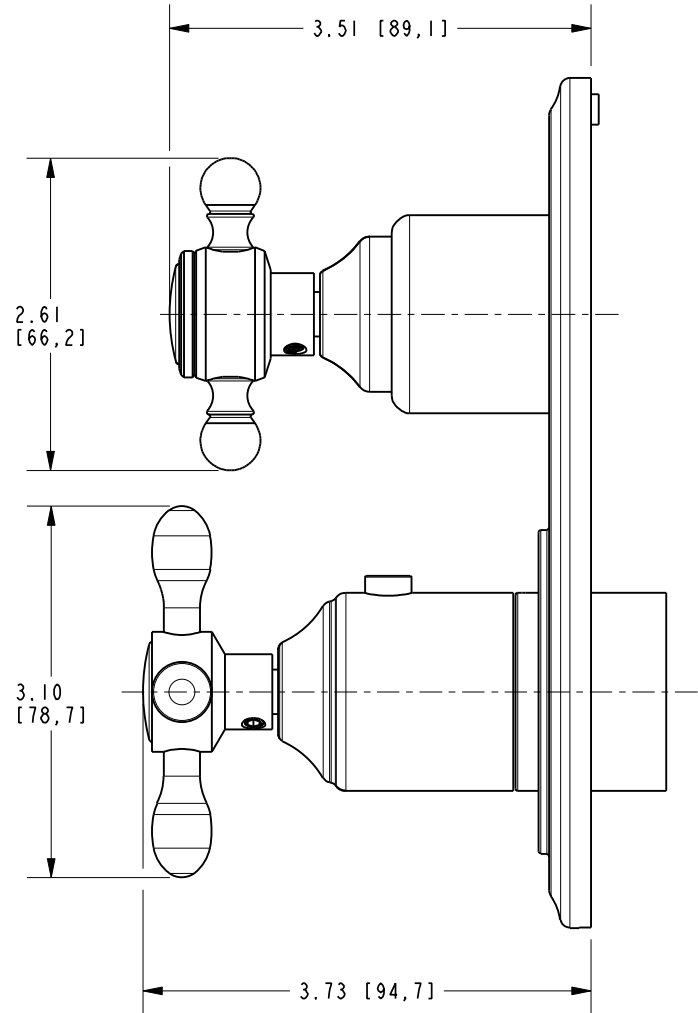

BRASSTECH INCORPORATED		2001 E. CARNEGIE AVE. SANTA ANA, CA 92705 (949) 417-5207	
DWG NO.	3-1643TR	REV	A
SCALE .625	REF.	SHEET 2	OF 2