

NOTES:

1. TO INSPECT ASSEMBLY, FOLLOW FIRST ARTICLE AND IN PROCESS INSPECTION SHEET.

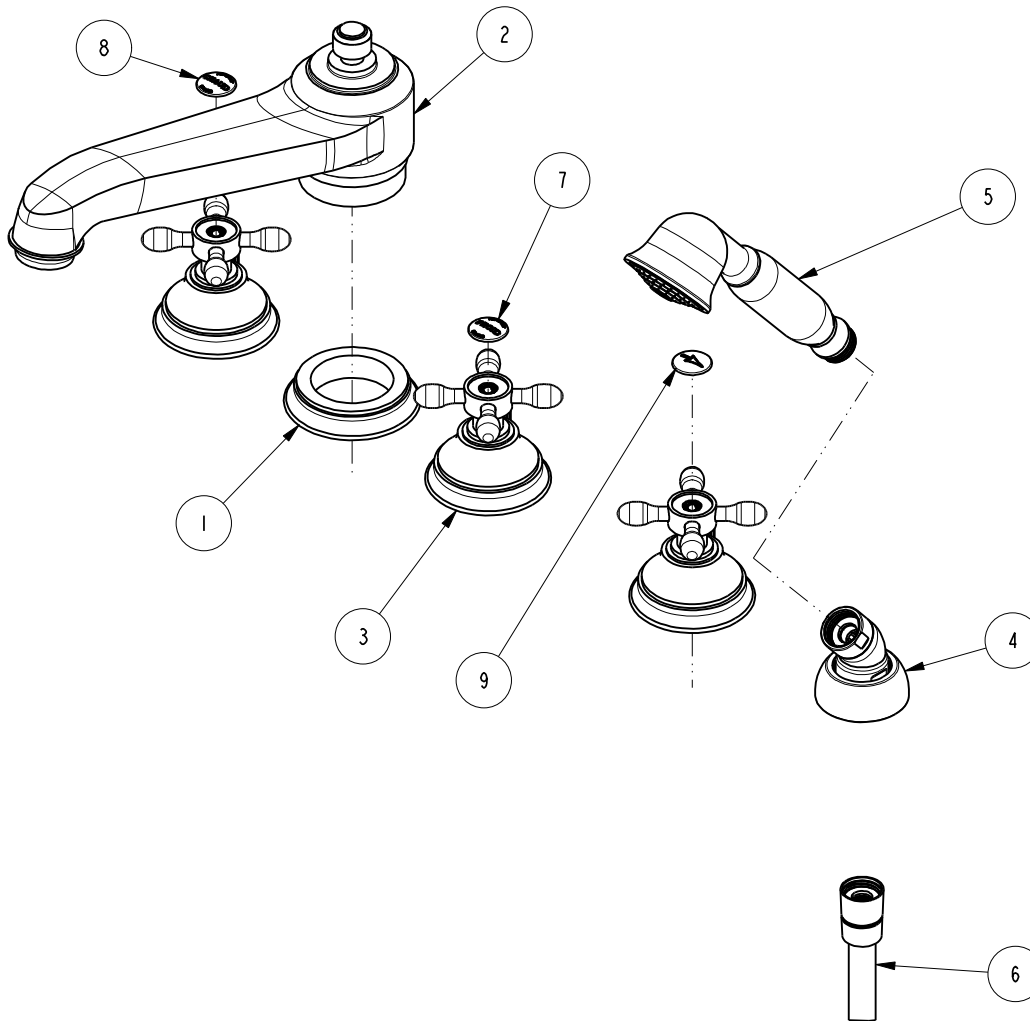

BILL OF MATERIAL (CURRENT LEVEL)

ITEM	PT/ASSY	DESCRIPTION	TYPE	QTY.
1	11135	R/T SPOUT ESCUTCHEON	PART	1
2	2-445	R/T SPOUT ASM	ASSEMBLY	1
3	3-280	HANDLE/ESCUTCHEON ASM	ASSEMBLY	3
4	6-289	DECK FLANGE TRIM	ASSEMBLY	1
5	281	HANDSHOWER ASM	ASSEMBLY	1
6	284	59 IN. SPIRAL SHOWER HOSE	ASSEMBLY	1
7	1-131	FROID BUTTON W/ADH. TAB	ASSEMBLY	1
8	1-130	CHAUD BUTTON W/ADH. TAB	ASSEMBLY	1
9	1-109	DIVERTER BUTTON W/ ADHESIVE	ASSEMBLY	1

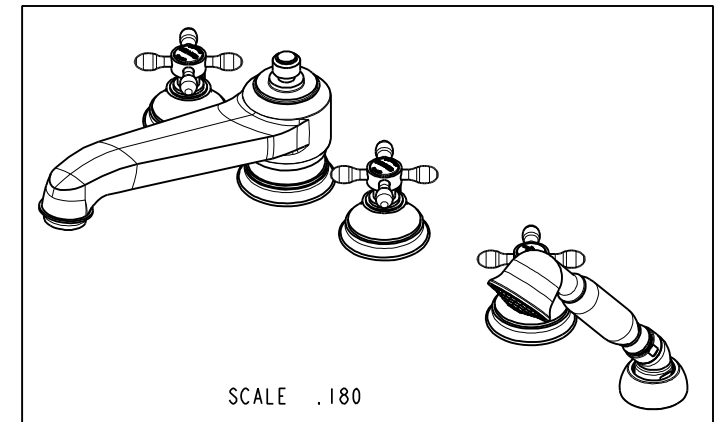

TESTING	ASSEMBLY	PLATING	POLISHING	MACHINING	TOOLING FIXTURE #
-	-	-	-	-	-
-	-	-	-	-	-
-	-	-	-	-	-
-	-	-	-	-	-
-	-	-	-	-	-

UNIT	DESCRIPTION	DATE	APPROVED
E	EN-4300w	02/02/21	R.S.
D	EN-3222	12/04/17	J.A.
-	EN-2032	01/07/13	-

TESTING	ASSEMBLY	PLATING	POLISHING	MACHINING	TOOLING FIXTURE #
-	-	-	-	-	-
-	-	-	-	-	-
-	-	-	-	-	-
-	-	-	-	-	-
-	-	-	-	-	-

TESTING	ASSEMBLY	PLATING	POLISHING	MACHINING	TOOLING FIXTURE #
-	-	-	-	-	-
-	-	-	-	-	-
-	-	-	-	-	-
-	-	-	-	-	-
-	-	-	-	-	-

<b>BRASSTECH INCORPORATED</b>		2001 CARNEGIE AVE. SANTA ANA, CA 92705 (949) 417-5207	
<b>TRIM KIT - 3-1647</b>			
DWG NO. <b>3-1647</b>		REV <b>E</b>	
SCALE <b>.250</b>	REF. <b>-</b>	SHEET <b>1</b>	OF <b>3</b>

COPYRIGHT 2005 BRASSTECH, INC.  
 THESE DRAWINGS AND THE DESIGNS  
 DEPICTED HEREIN ARE THE PROPRIETARY  
 PROPERTY OF BRASSTECH. ANY USE  
 OR REPRODUCTION IS SUBJECT TO  
 THE EXPRESS APPROVAL OF BRASSTECH.  
 UNAUTHORIZED USE IS STRICTLY  
 PROHIBITED. ALL RIGHTS RESERVED.

UNITS ARE: INCHES [MM]  
 TOLERANCES ARE:  
 FRACTIONS DECIMALS ANGLES  
 $\pm 1/16"$   $.X \pm .1$  (2,5)  $\pm 1^\circ$   
 $.XX \pm .06$  (1,5)

(X.XXX) DENOTES CRITICAL DIMS.  
 ALL THREADS ARE CRITICAL

DRAWN **JINSON** **02/02/21**

CHECKED **R.S.** **02/02/21**

APPROVED **R.S.** **02/02/21**

APPLICATION

REMOVE ALL BURRS AND SHARP EDGES

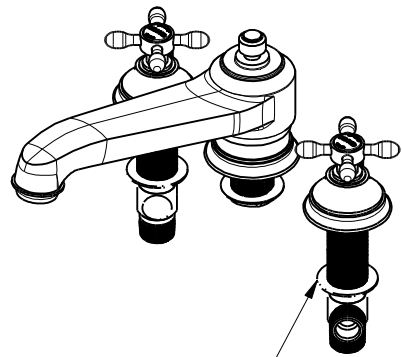

PN : 1-507  
SOLD SEPARATELY

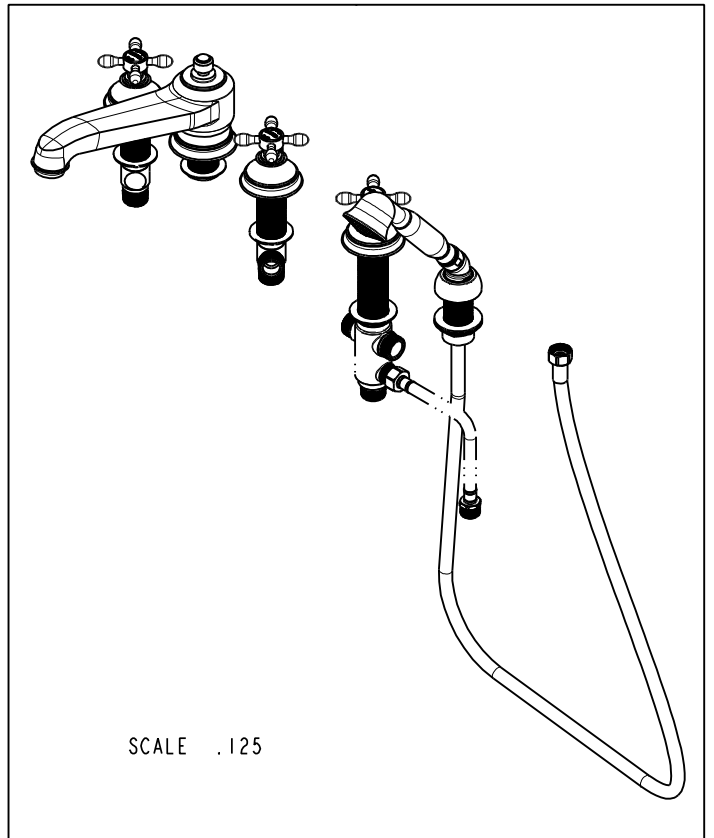
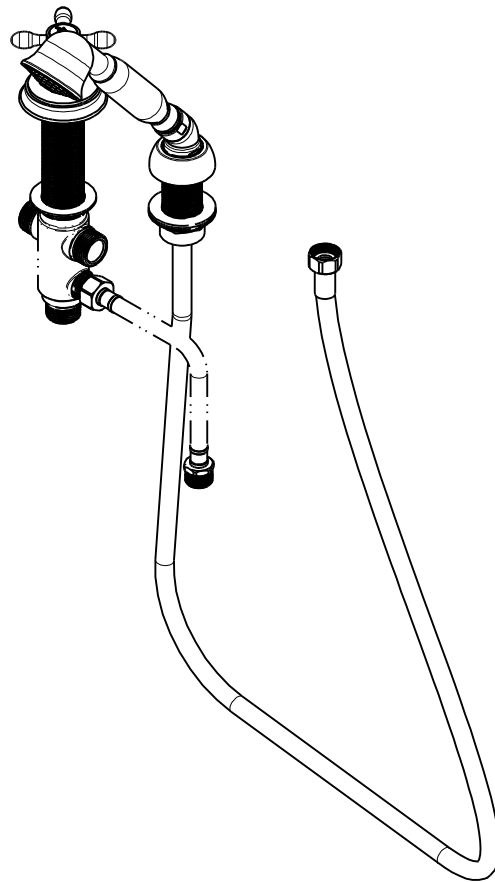

SCALE .125

<b>BRASSTECH</b>		2001 CARNEGIE AVE. SANTA ANA, CA 92705 (949) 417-5207	
INCORPORATED			
DWG NO.	3-1647	REV	E
SCALE .175	REF. -	SHEET 2 OF 3	

