

NOTES:

1. TO INSPECT ASSEMBLY, FOLLOW FIRST ARTICLE AND IN PROCESS INSPECTION SHEET.

BILL OF MATERIAL (CURRENT LEVEL)

ITEM	PT/ASSY	DESCRIPTION	TYPE	QTY.
1	1-110	BUTTON W/ADHESIVE	ASSEMBLY	1
2	2-217	DIVERTER TRIM KIT	ASSEMBLY	1
3	2-224	COVERPLATE BP W/DIVERTER	ASSEMBLY	1
4	2-564	TUB SPOUT	ASSEMBLY	1
5	3-280L	HANDLE/ESCUTCHEON ASM	ASSEMBLY	1
6	200	SHOWER ARM 6" BRASS	PART	1
7	206	SHOWER ARM FLANGE	PART	1
8	2156	SHOWER HEAD, TRAD	ASSEMBLY	1

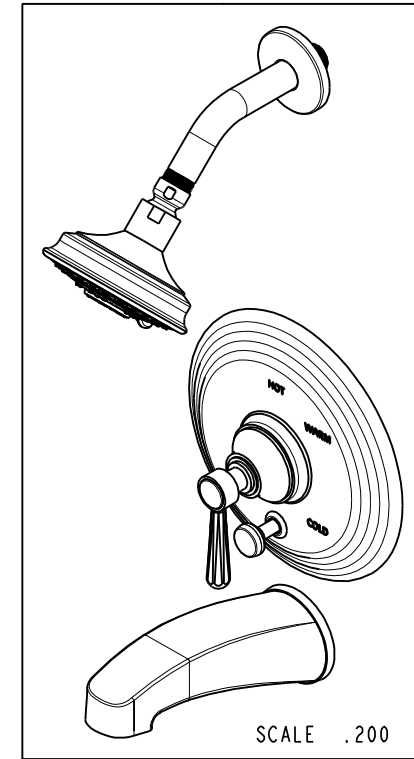
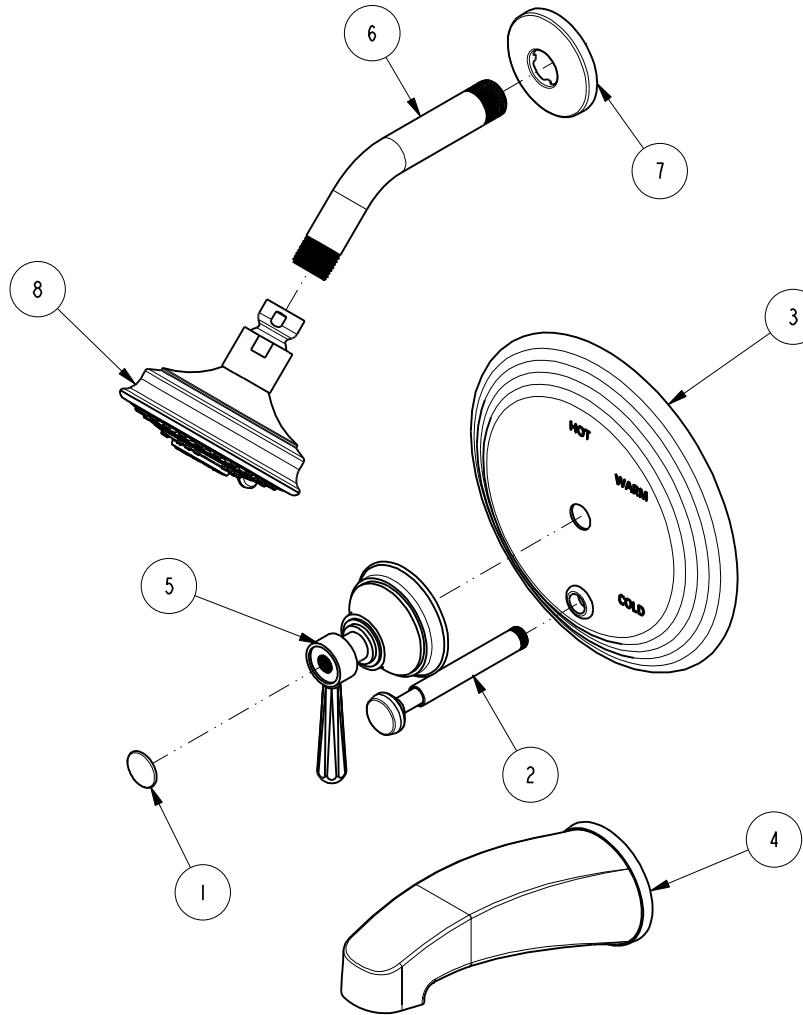

ZONE	REV	DESCRIPTION	DATE	APPROVED
-	C	EN-4300e	04/28/21	R.S.
-	B	EN-2802	09/05/14	-
-	A	EN-1745	08/22/11	-
-	-	EO-0299	03/04/04	-

COPYRIGHT 2005 BRASSTECH, INC. THESE DRAWINGS AND THE DESIGNS DEPICTED HEREIN ARE THE PROPRIETARY PROPERTY OF BRASSTECH. ANY USE OR REPRODUCTION IS SUBJECT TO THE EXPRESS APPROVAL OF BRASSTECH. UNAUTHORIZED USE IS STRICTLY PROHIBITED. ALL RIGHTS RESERVED.

TESTING	-	-	-
ASSEMBLY	-	-	-
PLATING	-	-	-
POLISHING	-	NEXT ASSY	USED ON
MACHINING	-	APPLICATION	
TOOLING FIXTURE #	REMOVE ALL BURRS AND SHARP EDGES		

UNITS ARE: INCHES [MM]	
TOLERANCES ARE:	
FRACTIONS DECIMALS	ANGLES
±1/16"	±°
.X ±.1 [2,5]	
.XX ±.06 [1,5]	
(X.XXX) DENOTES CRITICAL DIMS.	
ALL THREADS ARE CRITICAL	
DRAWN	JINSON 04/28/21
CHECKED	R.S. 04/28/21
APPROVED	R.S. 04/28/21

BRASSTECH 2001 CARNEGIE AVE.
INCORPORATED SANTA ANA, CA 92705
(949) 417-5207

TRIM KIT (3-1662BP)

DWG NO.	3-1662BP	REV	C
SCALE	.250	REF.	-
SHEET	1	OF	2

