

NOTES:

1. TO INSPECT ASSEMBLY, FOLLOW FIRST ARTICLE AND IN PROCESS INSPECTION SHEET.

BILL OF MATERIAL (CURRENT LEVEL)

ITEM	PT/ASSY	DESCRIPTION	TYPE	QTY.
1	2-337	THERMO ROUND PLATE ASSEMBLY	ASSEMBLY	1
2	11029	SLEEVE - THERMO	PART	1
3	2-339	THERMO BONNET ASM - CONT	ASSEMBLY	1
4	2-271	THERMO HANDLE ASM-2020	ASSEMBLY	1
5	92113	SCRW, M4 X .7 X 40 PHL FLT HD SS	PART	1
6	91308	TEMP LIMIT STOP - THERMO	PART	1

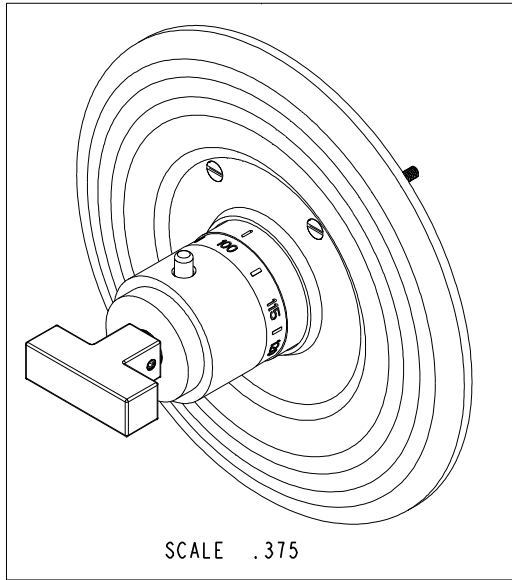

SCALE .375

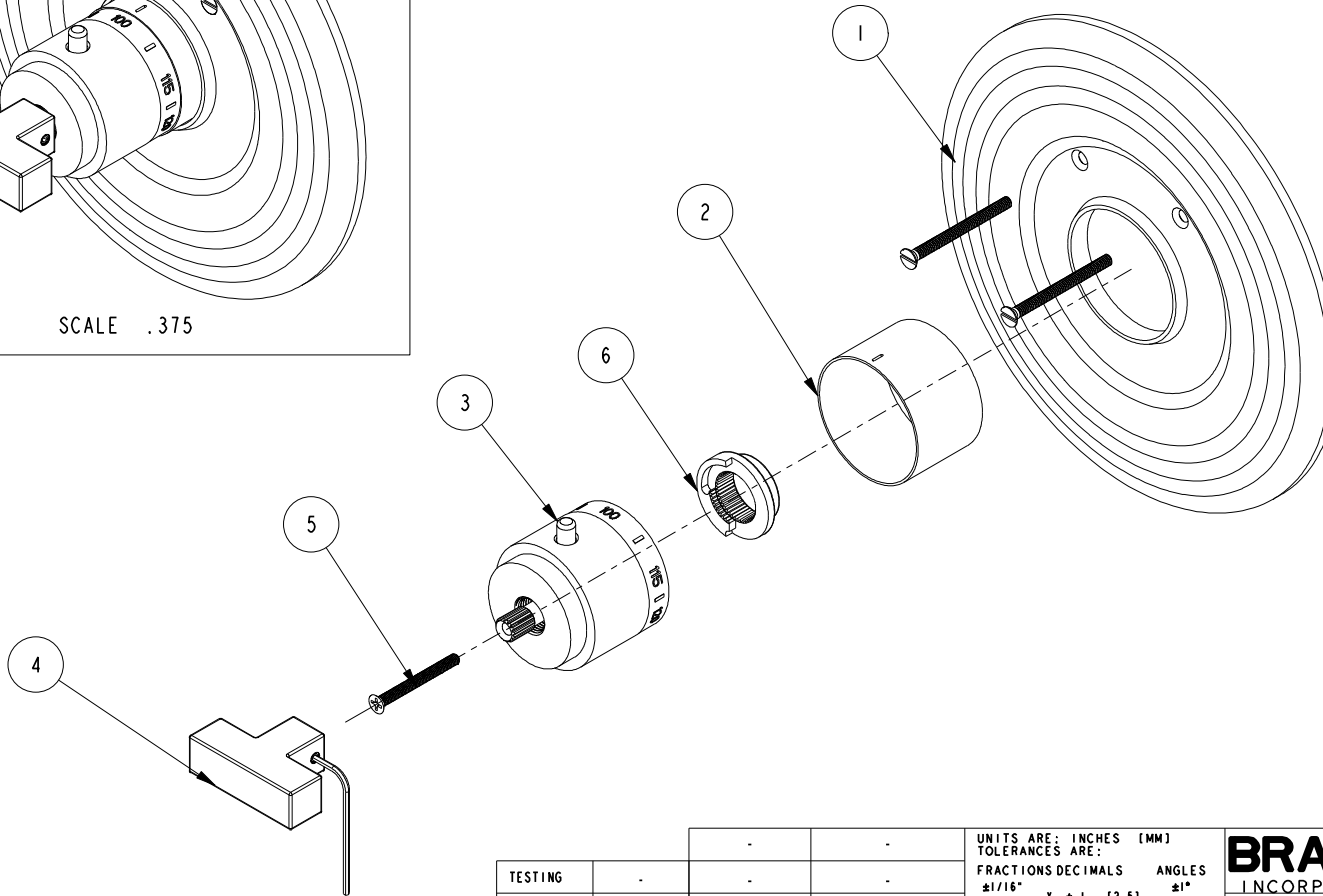

TESTING	-	-	-
ASSEMBLY	-	-	-
PLATING	-	-	-
POLISHING	-	NEXT ASSY	USED ON
MACHINING	-	APPLICATION	
TOOLING FIXTURE #	REMOVE ALL BURRS AND SHARP EDGES		

UNITS ARE: INCHES [MM]
 TOLERANCES ARE:
 FRACTIONS DECIMALS ANGLES
 ±1/16" .X ±.1 [2.5] ±1°
 .XX ±.06 [1.5]

(X.XXX) DENOTES CRITICAL DIMS.
 ALL THREADS ARE CRITICAL

DRAWN	-	03/01/01
CHECKED	-	03/01/01
APPROVED	-	03/01/01

BRASSTECH
 INCORPORATED

2001 CARNEGIE AVE.
 SANTA ANA, CA 92705
 (949) 417-5207

ROUND TRIM THERMO

DWG NO.	3-2024TR		REV	B
SCALE	.375	REF.	-	SHEET 1 OF 3

-	B	EN-3961-2	06/23/20	J.M.	COPYRIGHT 2005 BRASSTECH, INC. THESE DRAWINGS AND THE DESIGNS DEPICTED HEREIN ARE THE PROPRIETARY PROPERTY OF BRASSTECH. ANY USE OR REPRODUCTION IS SUBJECT TO THE EXPRESS APPROVAL OF BRASSTECH. UNAUTHORIZED USE IS STRICTLY PROHIBITED. ALL RIGHTS RESERVED.
-	A	EO-0078	09/16/02	-	
-	-	RELEASED	03/01/01	-	
ZONE	REV	DESCRIPTION	DATE	APPROVED	

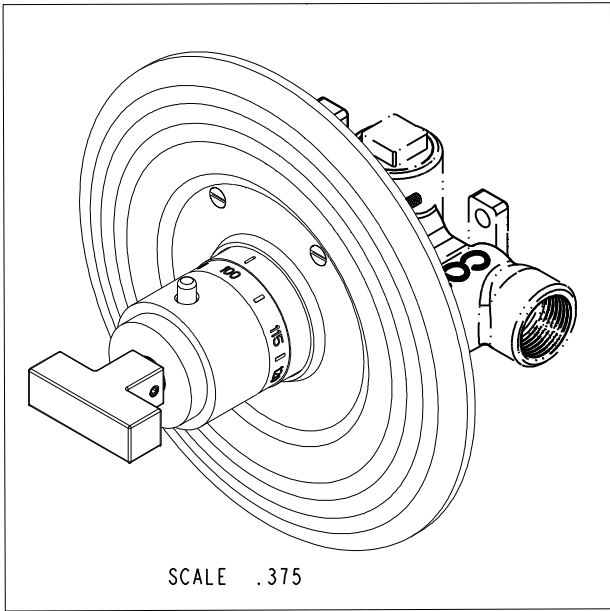

SCALE .375

PN: 1-540 SOLD SEPARATELY

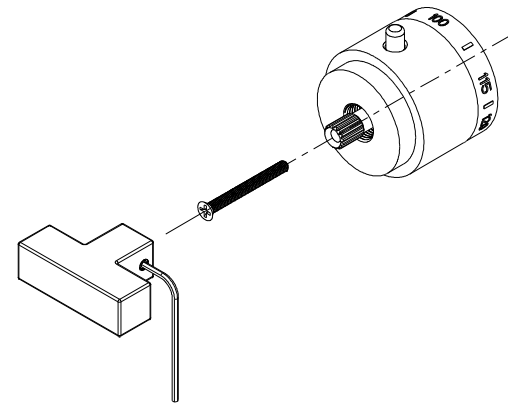
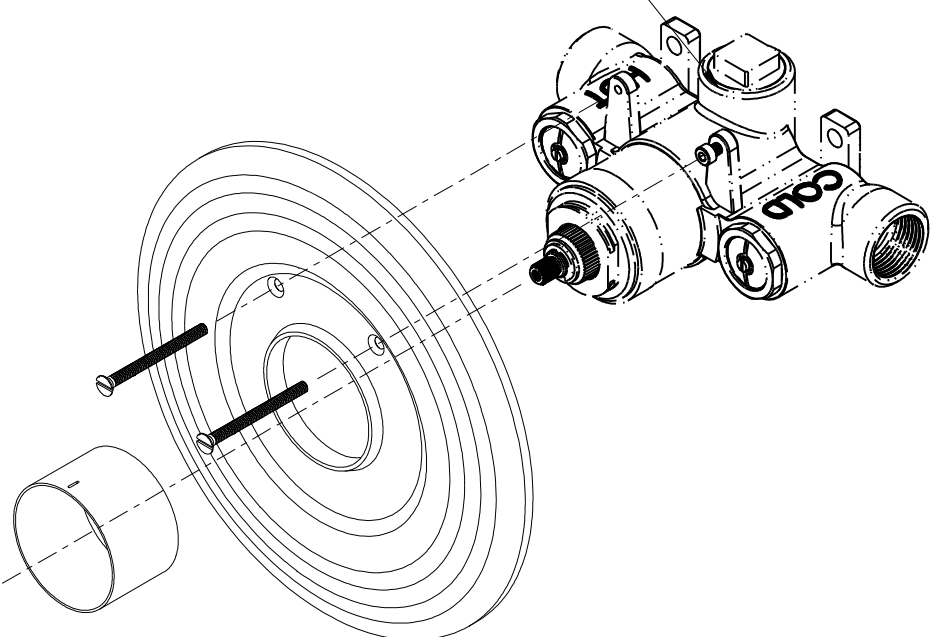

BRASSTECH		2001 CARNEGIE AVE. SANTA ANA, CA 92705 (949) 417-5207
INCORPORATED		
DWG NO.	3-2024TR	REV B
SCALE .375	REF. -	SHEET 2 OF 3

