

NOTES:

1. TO INSPECT ASSEMBLY, FOLLOW FIRST ARTICLE AND IN PROCESS INSPECTION SHEET.

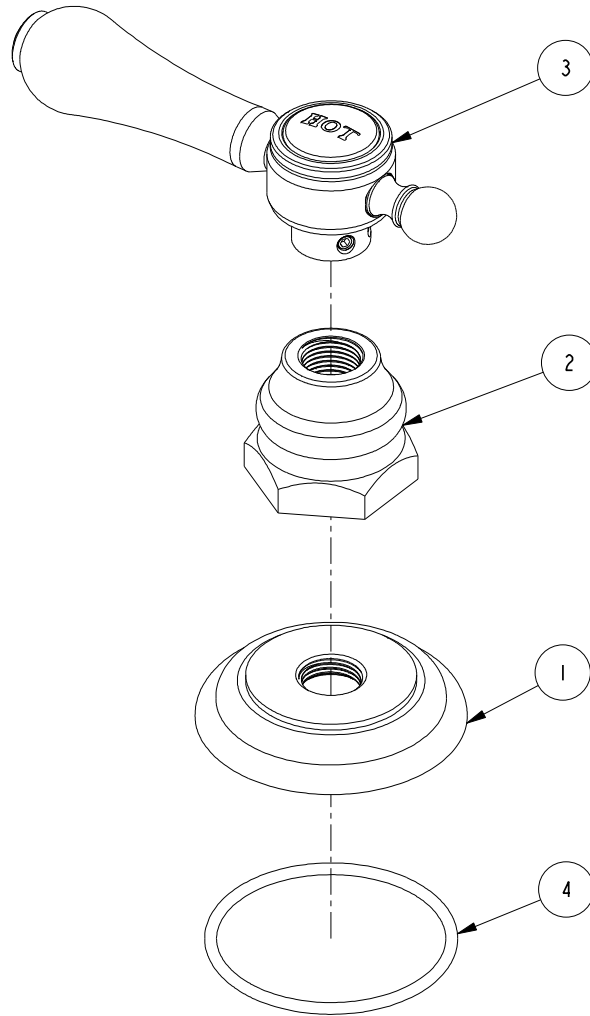

**BILL OF MATERIAL (CURRENT LEVEL)**

ITEM	PT/ASSY	DESCRIPTION	TYPE	QTY.
1	10050	ESCUTCHEON WALL VALVE	PART	1
2	10523	HEX ESCUTCHEON BONNET	PART	1
3	2-134	HANDLE ASSEMBLY - HOT	ASSEMBLY	1
4	91753	O-RING, # 2-136, EP, 50 DURO - GREY	PART	1

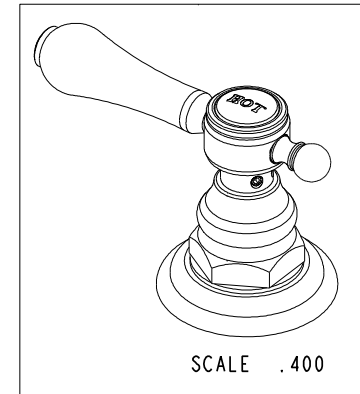

-	C	EN-4300j	12/16/20	R.S.
-	B	EN-3722	02/08/19	C.G.
-	A	EN-2398A	04/11/13	-
-	-	RELEASED	06/02/03	-
ZONE	REV	DESCRIPTION	DATE	APPROVED

COPYRIGHT 2005 BRASSTECH, INC. THESE DRAWINGS AND THE DESIGNS DEPICTED HEREIN ARE THE PROPRIETARY PROPERTY OF BRASSTECH. ANY USE OR REPRODUCTION IS SUBJECT TO THE EXPRESS APPROVAL OF BRASSTECH. UNAUTHORIZED USE IS STRICTLY PROHIBITED. ALL RIGHTS RESERVED.

TESTING	-	-	-
ASSEMBLY	-	-	-
PLATING	-	3-1031	1031
POLISHING	-	NEXT ASSY	USED ON
MACHINING	-	APPLICATION	
TOOLING FIXTURE #	REMOVE ALL BURRS AND SHARP EDGES		

UNITS ARE: INCHES [MM]		
TOLERANCES ARE:		
FRACTIONS	DECIMALS	ANGLES
±1/16"	.X ±.1 [2.5]	±1°
	.XX ±.06 [1.5]	
(X.XXX) DENOTES CRITICAL DIMS.		
ALL THREADS ARE CRITICAL		
DRAWN	JIMSON	12/16/20
CHECKED	R.S.	12/16/20
APPROVED	R.S.	12/16/20

<b>BRASSTECH</b>		2001 CARNEGIE AVE. SANTA ANA, CA 92705 (949) 417-5207	
INCORPORATED			
TRIM KIT - HANDLE ESCUTCHEON-HOT			
DWG NO.		REV	
3-241H		C	
SCALE	REF.	SHEET	OF
.600	-	1	2

