

NOTES:

1. TO INSPECT ASSEMBLY, FOLLOW FIRST ARTICLE AND IN PROCESS INSPECTION SHEET.

BILL OF MATERIAL (CURRENT LEVEL)

ITEM	PT/ASSY	DESCRIPTION	TYPE	QTY.
1	1-331	THERMO WALL PLATE ASM	ASSEMBLY	1
2	12123	THERMO PLATE	PART	1
3	91308	TEMP LIMIT STOP - THERMO	PART	1
4	8-076	THERMO BONNET W/ KNOB HANDLE ASM	ASSEMBLY	1
5	11029	SLEEVE - THERMO	PART	1
6	10159	HEX KEY, 3/32 ALLOY STEEL	PART	1

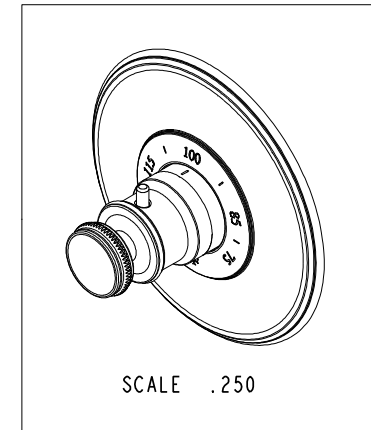
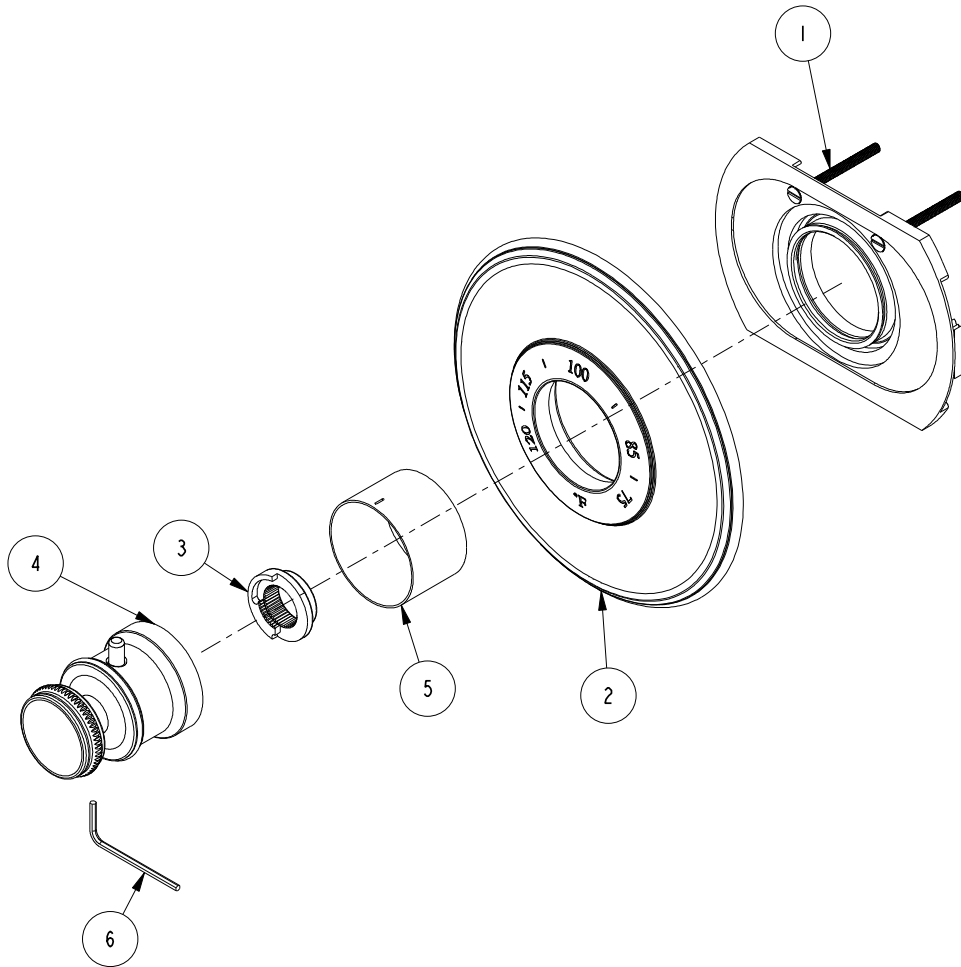

ZONE	REV	DESCRIPTION	DATE	APPROVED
-	B	EN-3961-2	07/02/20	J.M.
-	A	EN-2791	08/11/14	-
-	-	EN-1735	06/10/11	-

COPYRIGHT 2005 BRASSTECH, INC. THESE DRAWINGS AND THE DESIGNS DEPICTED HEREIN ARE THE PROPRIETARY PROPERTY OF BRASSTECH. ANY USE OR REPRODUCTION IS SUBJECT TO THE EXPRESS APPROVAL OF BRASSTECH. UNAUTHORIZED USE IS STRICTLY PROHIBITED. ALL RIGHTS RESERVED.

TESTING	-	-	-
ASSEMBLY	-	-	-
PLATING	-	-	-
POLISHING	-	NEXT ASSY	USED ON
MACHINING	-	APPLICATION	
TOOLING FIXTURE #	REMOVE ALL BURRS AND SHARP EDGES		

UNITS ARE: INCHES [MM]	
TOLERANCES ARE:	
FRACTIONS	DECIMALS
±1/16"	.X ±.1 [2.5]
	.XX ±.06 [1.5]
(X.XXX) DENOTES CRITICAL DIMS.	
ALL THREADS ARE CRITICAL	
DRAWN	06/10/11
CHECKED	06/10/11
APPROVED	06/10/11

BRASSTECH 2001 CARNEGIE AVE.
INCORPORATED SANTA ANA, CA 92705
(949) 417-5207

THERMOSTATIC TRIM PLATE WITH HANDLE

DWG NO. **3-2554TR** REV **B**

SCALE .312 REF. - SHEET 1 OF 3

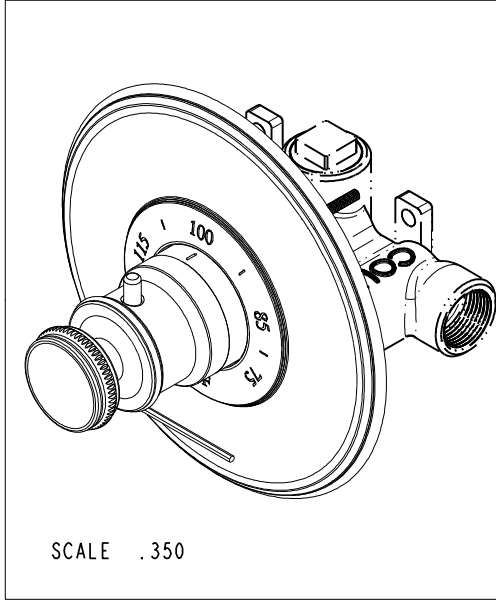

PN: 1-540
SOLD SEPARATELY

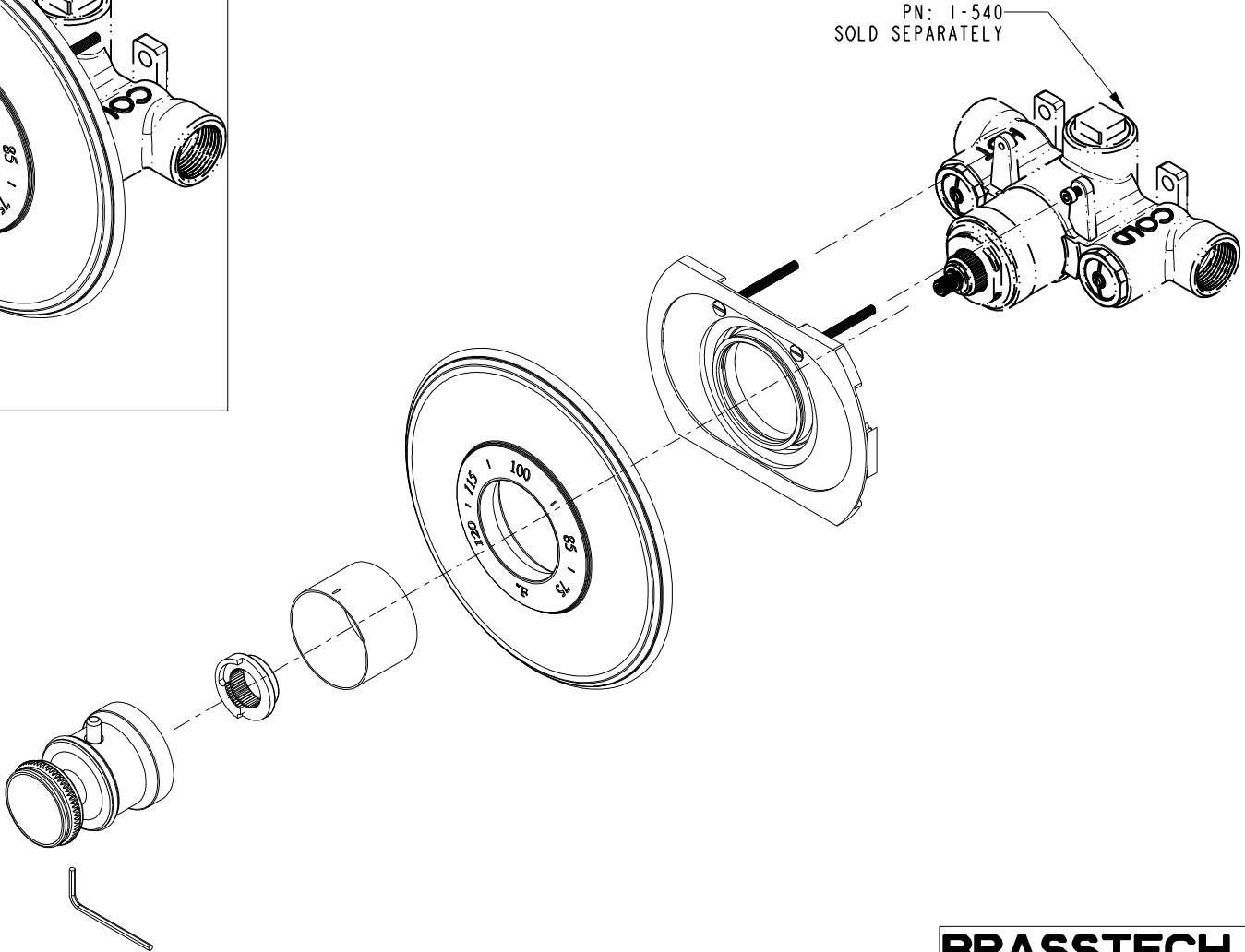

BRASSTECH		2001 CARNEGIE AVE. SANTA ANA, CA 92705 (949) 417-5207
INCORPORATED		REV
DWG NO.	3-2554TR	B
SCALE .312	REF. -	SHEET 2 OF 3

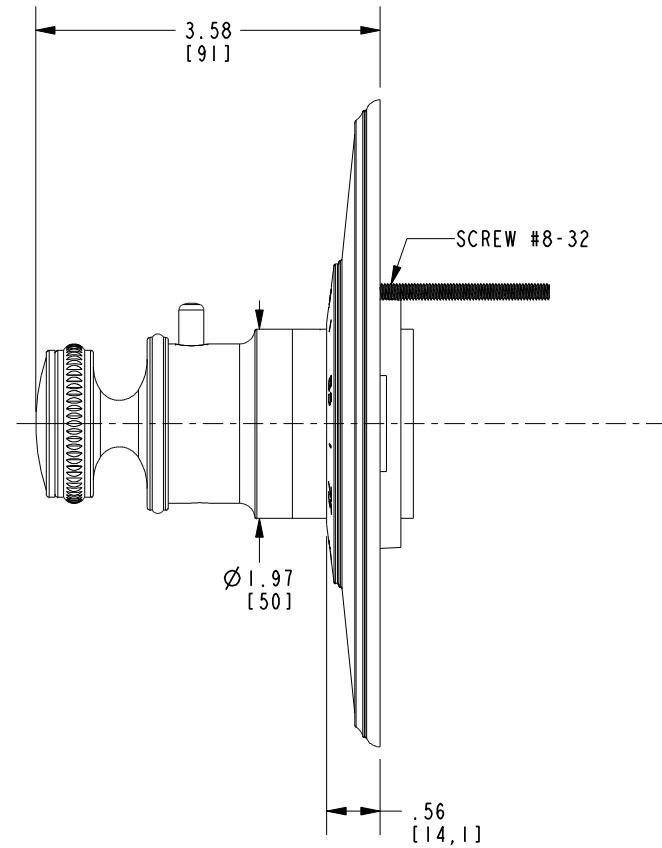
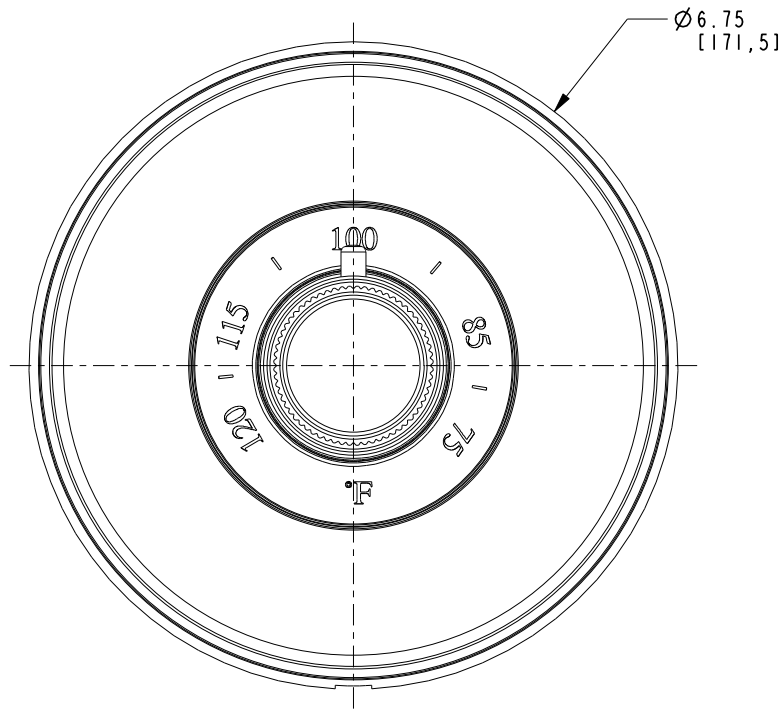

BRASSTECH		2001 CARNEGIE AVE. SANTA ANA, CA 92705 (949) 417-5207	
INCORPORATED			
DWG NO.	3-2554TR	REV	B
SCALE .400	REF. -	SHEET 3	OF 3