

NOTES:

1. TO INSPECT ASSEMBLY, FOLLOW FIRST ARTICLE AND IN PROCESS INSPECTION SHEET.

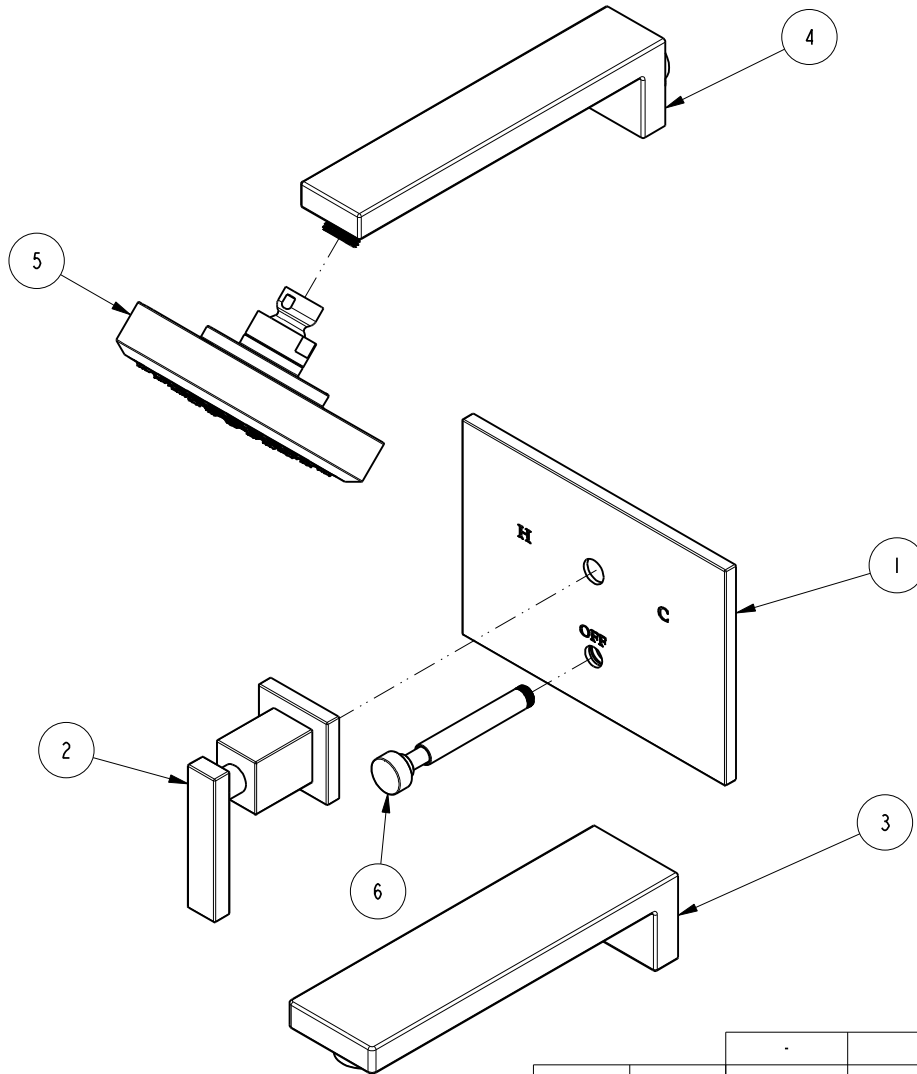

BILL OF MATERIAL (CURRENT LEVEL)

ITEM	PT/ASSY	DESCRIPTION	TYPE	QTY.
1	2-641	BP TUB SHOWER PLATE ASSEMBLY	ASSEMBLY	1
2	3-368	HANDLE AND ESCUTCHEON ASSEMBLY	ASSEMBLY	1
3	8-030	WALL TUB SPOUT ASM	ASSEMBLY	1
4	201-2	9" SHOWER ARM [METRO]	ASSEMBLY	1
5	2141	CONTEMP. SHOWER HEAD - SINGLE JET	ASSEMBLY	1
6	2-618	DIVERTER TRIM KIT	ASSEMBLY	1

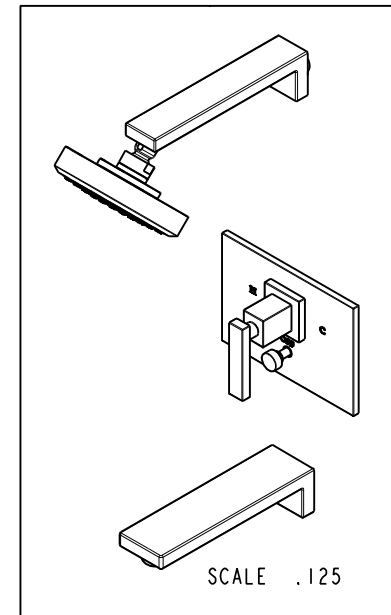

ZONE	REV	DESCRIPTION	DATE	APPROVED
-	A	EN-4300e	04/28/21	R.S.
-	-	EN-2108	04/03/12	-

COPYRIGHT 2005 BRASSTECH, INC. THESE DRAWINGS AND THE DESIGNS DEPICTED HEREIN ARE THE PROPRIETARY PROPERTY OF BRASSTECH. ANY USE OR REPRODUCTION IS SUBJECT TO THE EXPRESS APPROVAL OF BRASSTECH. UNAUTHORIZED USE IS STRICTLY PROHIBITED. ALL RIGHTS RESERVED.

TESTING	-	-	-
ASSEMBLY	-	-	-
PLATING	-	-	-
POLISHING	-	NEXT ASSY	USED ON
MACHINING	-	APPLICATION	
TOOLING FIXTURE #	REMOVE ALL BURRS AND SHARP EDGES		

UNITS ARE: INCHES [MM]		
TOLERANCES ARE:		
FRACTIONS	DECIMALS	ANGLES
±1/16"	.X ±.1 [2,5]	±°
	.XX ±.06 [1,5]	
(X.XXX) DENOTES CRITICAL DIMS.		
ALL THREADS ARE CRITICAL		
DRAWN	JINSON	04/28/21
CHECKED	R.S.	04/28/21
APPROVED	R.S.	04/28/21

**BRASSTECH** 2001 CARNEGIE AVE.  
INCORPORATED SANTA ANA, CA 92705  
(949) 417-5207

**BP TUB/SHOWER SET**

DWG NO. **3-2562BP** REV **A**

SCALE .250 REF. - SHEET 1 OF 2

