

NOTES:

1. TO INSPECT ASSEMBLY, FOLLOW FIRST ARTICLE AND IN PROCESS INSPECTION SHEET.

BILL OF MATERIAL (CURRENT LEVEL)

ITEM	PT/ASSY	DESCRIPTION	TYPE	QTY.
1	12119	THERMO PLATE	PART	1
2	1-331	THERMO WALL PLATE ASM	ASSEMBLY	1
3	91308	TEMP LIMIT STOP - THERMO	PART	1
4	2-683	THERMO BONNET ASM	ASSEMBLY	1
5	11029	SLEEVE - THERMO	PART	1
6	92113	SCRW, M4 X .7 X 40 PHL FLT HD SS	PART	1
7	20-147	HANDLE ASM	ASSEMBLY	1

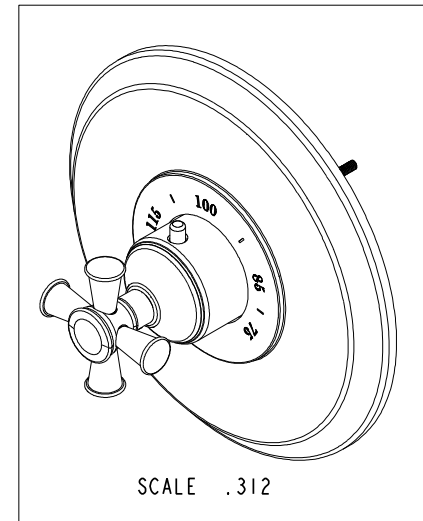
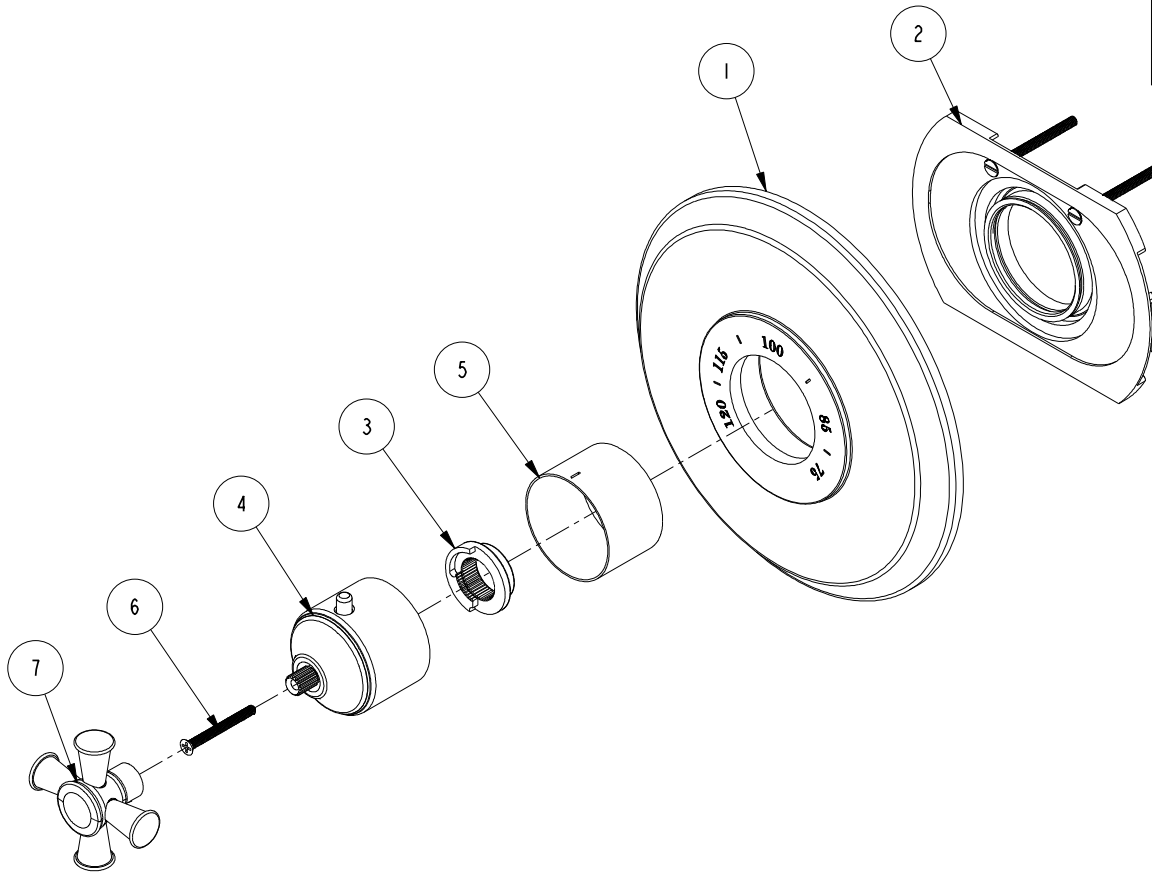

ZONE	REV	DESCRIPTION	DATE	APPROVED	TESTING	ASSEMBLY	PLATING	POLISHING	MACHINING	TOOLING FIXTURE #	APPLICATION
-	A	EN-3961-2	07/06/20	J.M.	-	-	-	-	-	-	-
-	-	EN-2982	12/08/15	J.M.	-	-	-	-	-	-	REMOVE ALL BURRS AND SHARP EDGES

COPYRIGHT 2005 BRASSTECH, INC. THESE DRAWINGS AND THE DESIGNS DEPICTED HEREIN ARE THE PROPRIETARY PROPERTY OF BRASSTECH. ANY USE OR REPRODUCTION IS SUBJECT TO THE EXPRESS APPROVAL OF BRASSTECH. UNAUTHORIZED USE IS STRICTLY PROHIBITED. ALL RIGHTS RESERVED.

UNITS ARE: INCHES [MM]		
TOLERANCES ARE:		
FRACTIONS	DECIMALS	ANGLES
±1/16"	.X ±.1 [2.5]	±1°
	.XX ±.06 [1.5]	
(X.XXX) DENOTES CRITICAL DIMS. ALL THREADS ARE CRITICAL		
DRAWN	R.S.	12/08/15
CHECKED	J.M.	12/08/15
APPROVED	J.M.	12/08/15

BRASSTECH 2001 CARNEGIE AVE. SANTA ANA, CA 92705 (949) 417-5207
INCORPORATED

3/4" THERMO TRIM

DWG NO. **3-2904TR** REV **A**

SCALE .312 REF. - SHEET 1 OF 3

4

3

2

1

D

D

C

C

B

B

A

A

PN: I-540 SOLD SEPARATELY

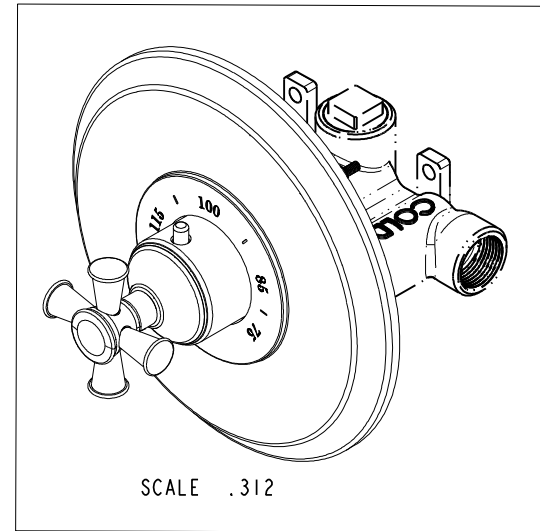
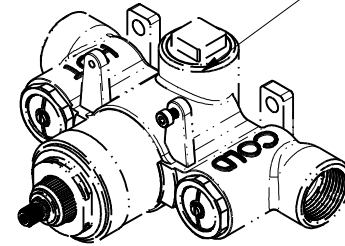
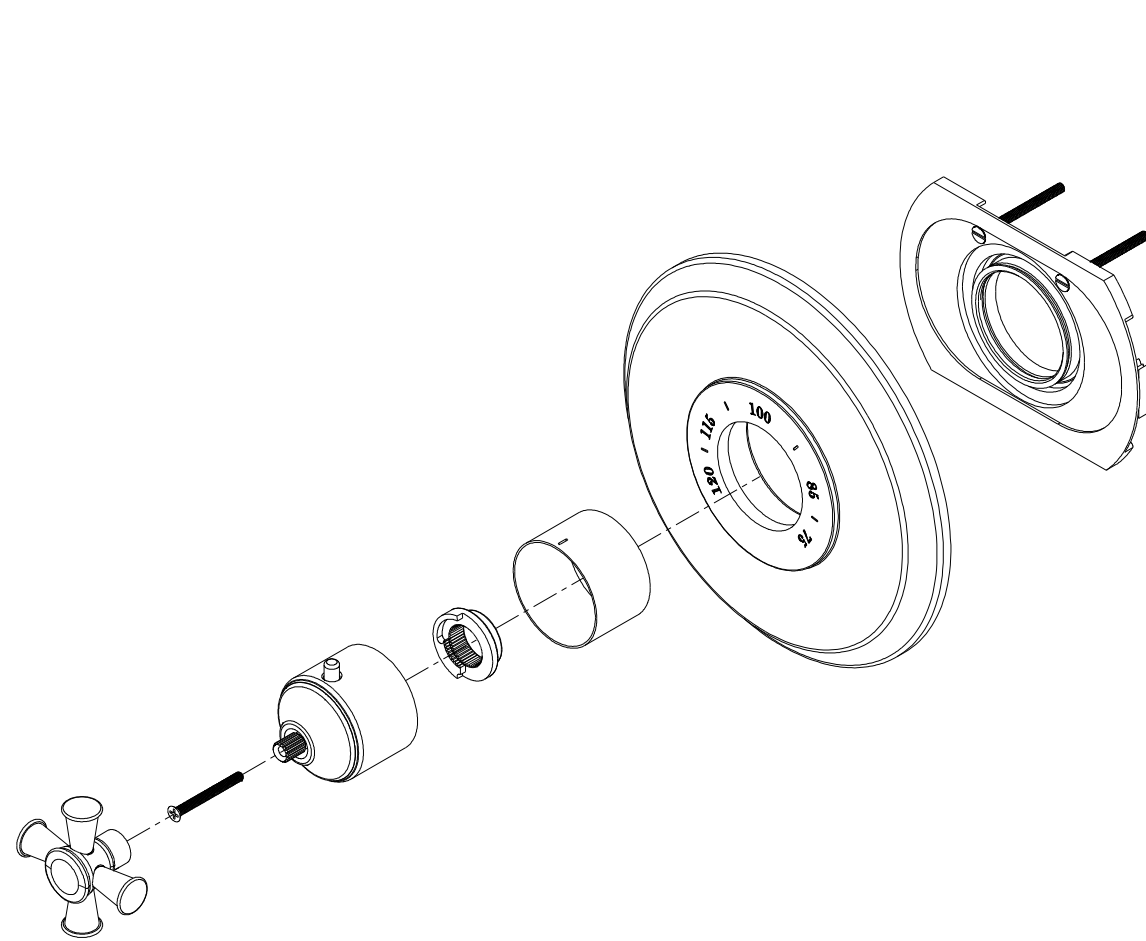

BRASSTECH

2001 CARNEGIE AVE.
SANTA ANA, CA 92705
(949) 417-5207

INCORPORATED

DWG NO.

3-2904TR

REV

A

SCALE .375

REF. -

SHEET 2 OF 3

4

3

2

1

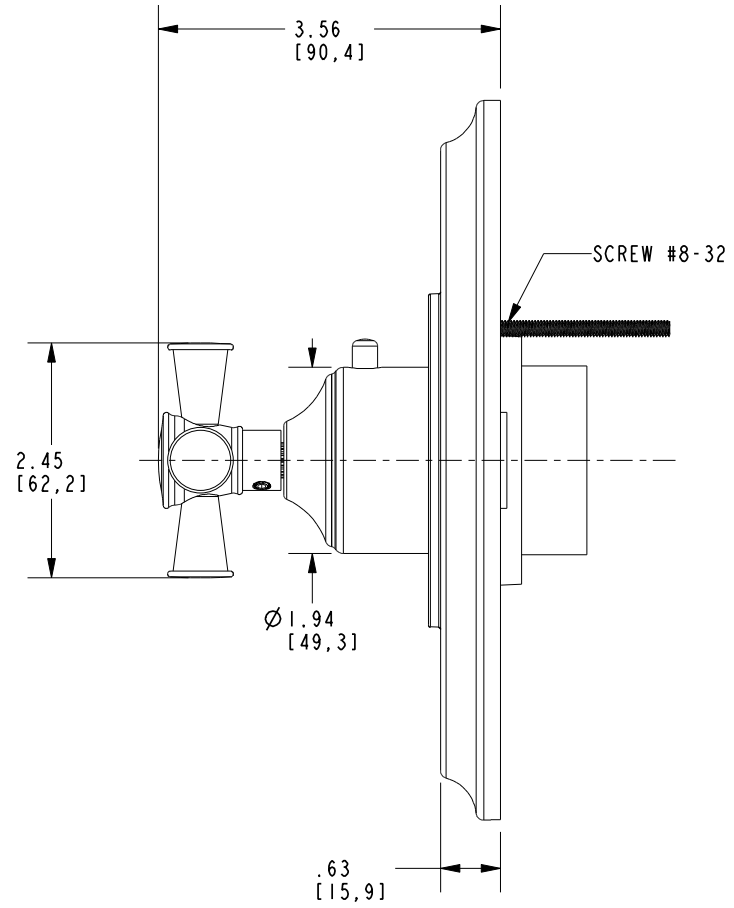
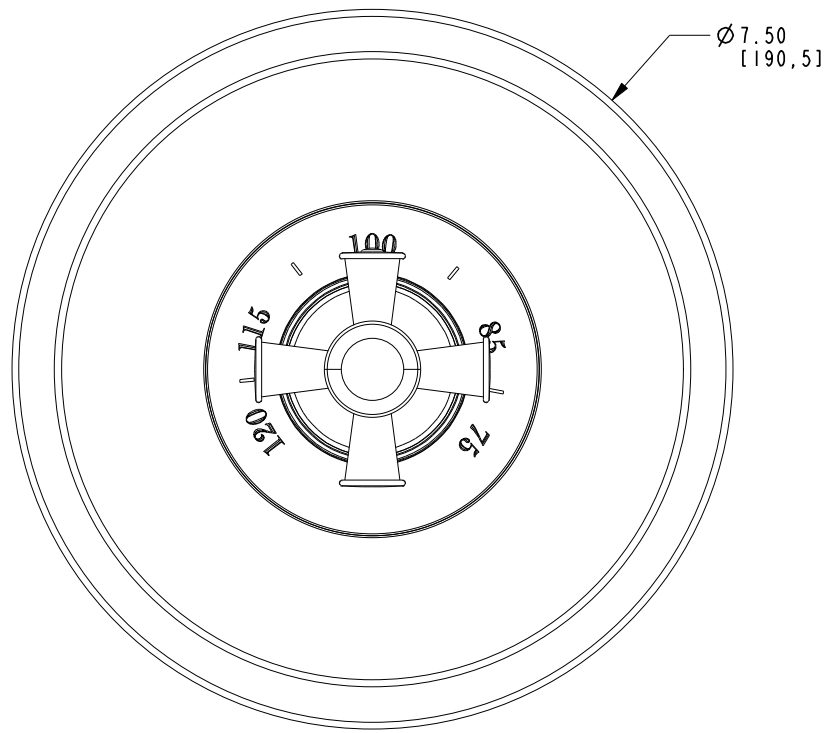

BRASSTECH

2001 CARNEGIE AVE.
SANTA ANA, CA 92705
(949) 417-5207

INCORPORATED

DWG NO.

3-2904TR

REV

A

SCALE .375

REF. -

SHEET 3 OF 3