

NOTES:

1. TO INSPECT ASSEMBLY, FOLLOW FIRST ARTICLE AND IN PROCESS INSPECTION SHEET.
2. SEAL NUT 10259 IN A PLASTIC BAG AND TAPE TO THE BACK OF THE TRIM PLATE.

**BILL OF MATERIAL (CURRENT LEVEL)**

ITEM	PT/ASSY	DESCRIPTION	TYPE	QTY.
1	3-234	WALL TUB SPOUT ASM	ASSEMBLY	1
2	2-438	COVERPLATE BP W/DIV ASM	ASSEMBLY	1
3	2-217	DIVERTER TRIM KIT	ASSEMBLY	1
4	206	SHOWER ARM FLANGE	PART	1
5	200	SHOWER ARM 6" BRASS	PART	1
6	2155	SHOWER HEAD, CONTEMP	ASSEMBLY	1
7	3-570	HANDLE/ ESC ASM	ASSEMBLY	1
8	10259	HEX NUT 9/16 X 20 MADE	PART	1

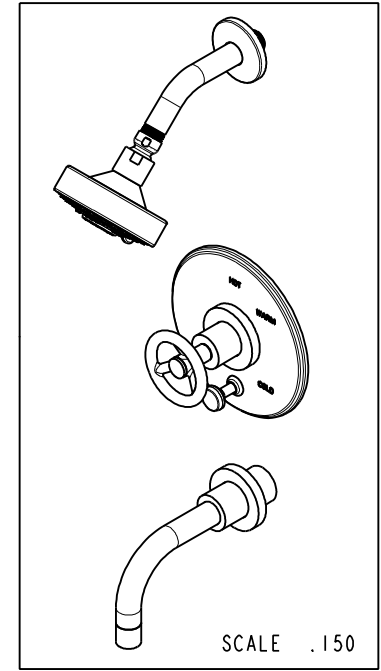
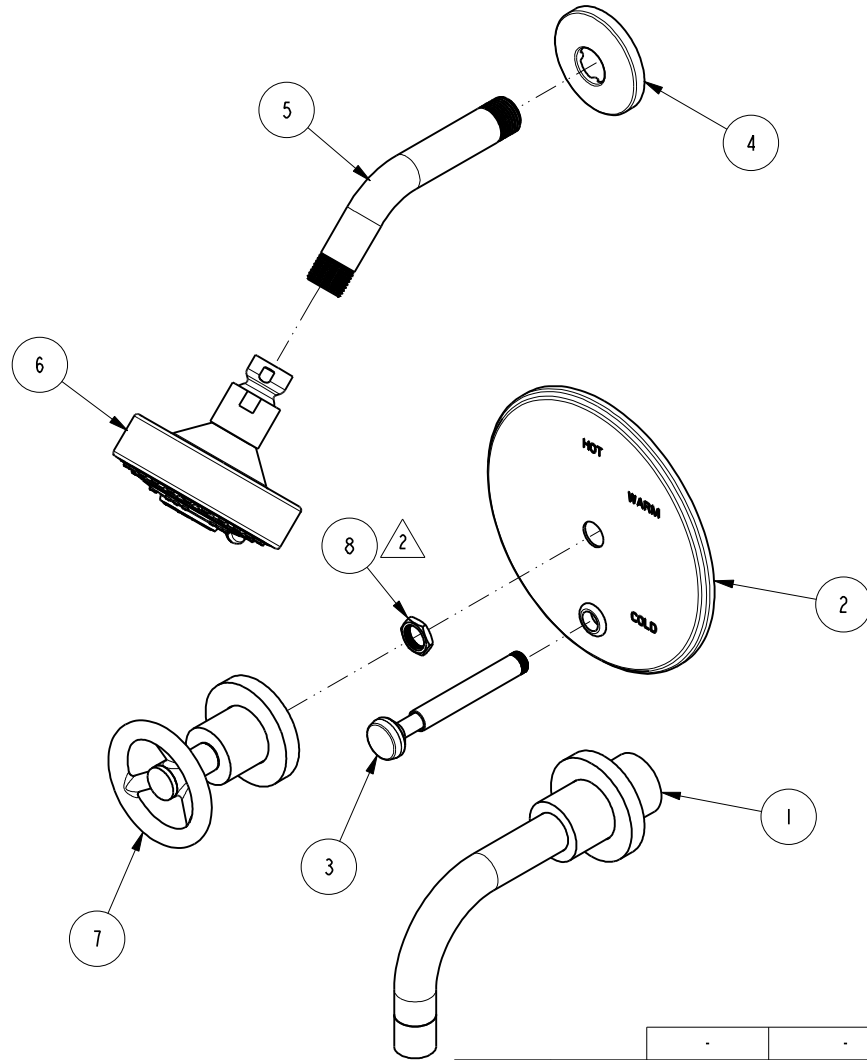

ZONE	REV	DESCRIPTION	DATE	APPROVED
-	C	EN-4441	04/18/22	N.S.
-	B	EN-4300e	04/28/21	R.S.
-	A	EN-3242	01/27/17	AN
-	-	EN-3005b	03/21/16	AN

COPYRIGHT 2005 BRASSTECH, INC. THESE DRAWINGS AND THE DESIGNS DEPICTED HEREIN ARE THE PROPRIETARY PROPERTY OF BRASSTECH. ANY USE OR REPRODUCTION IS SUBJECT TO THE EXPRESS APPROVAL OF BRASSTECH. UNAUTHORIZED USE IS STRICTLY PROHIBITED. ALL RIGHTS RESERVED.

TESTING	-	-	-
ASSEMBLY	-	-	-
PLATING	-	-	-
POLISHING	-	NEXT ASSY	USED ON
MACHINING	-	APPLICATION	
TOOLING FIXTURE #	REMOVE ALL BURRS AND SHARP EDGES		

UNITS ARE: INCHES [MM]	
TOLERANCES ARE:	
FRACTIONS DECIMALS	ANGLES
±1/16"	±1°
.X ±.1 [2.5]	
.XX ±.06 [1.5]	
(X.XXX) DENOTES CRITICAL DIMS.	
ALL THREADS ARE CRITICAL	
DRAWN	J.T. 04/18/22
CHECKED	N.S. 04/18/22
APPROVED	N.S. 04/18/22

**BRASSTECH** 2001 CARNEGIE AVE. SANTA ANA, CA 92705 (949) 417-5207  
INCORPORATED

**BP TUB & SHOWER TRIM SET**

DWG NO. **3-2922BP** REV **C**

SCALE .250 REF. - SHEET 1 OF 2

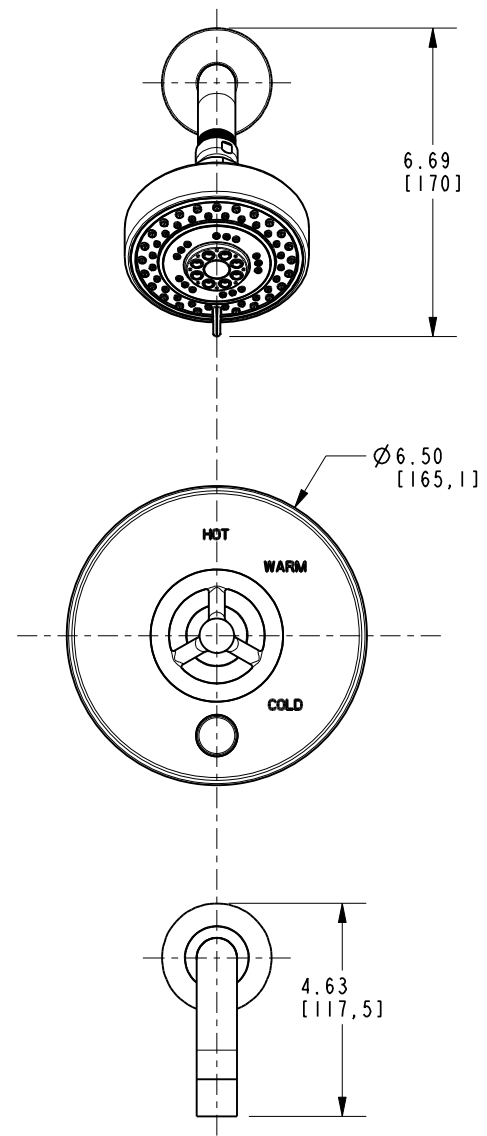
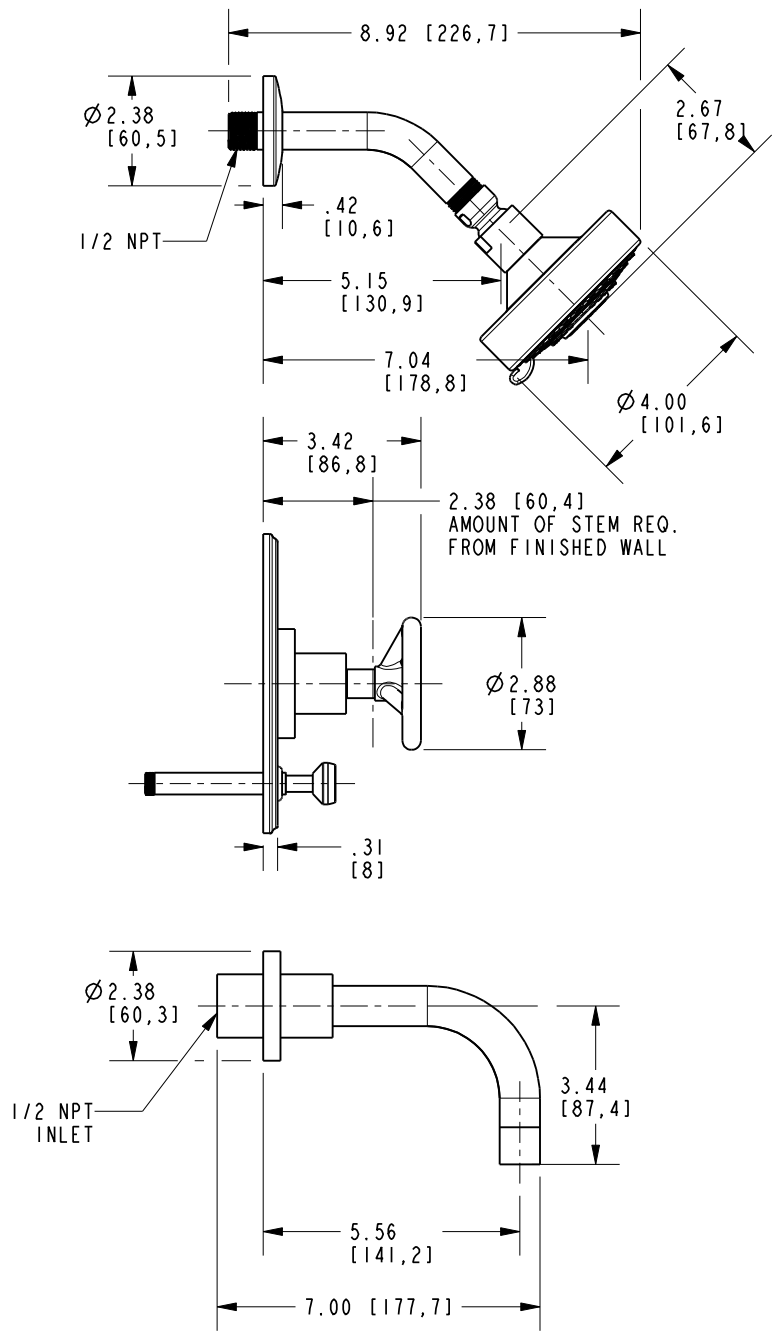

<b>BRASSTECH</b>		2001 E. CARNEGIE AVE. SANTA ANA, CA 92705 (949) 417-5207	
DWG NO.	3-2922BP		REV C
SCALE .300	REF. -	SHEET 2 OF 2	