

NOTES:

1. TO INSPECT ASSEMBLY, FOLLOW FIRST ARTICLE AND IN PROCESS INSPECTION SHEET.

BILL OF MATERIAL (CURRENT LEVEL)

ITEM	PT/ASSY	DESCRIPTION	TYPE	QTY.
1	3-225	R/T SPOUT ASM	ASSEMBLY	1
2	3-573	HANDLE AND ESCUTCHEON ASSEMBLY	ASSEMBLY	2

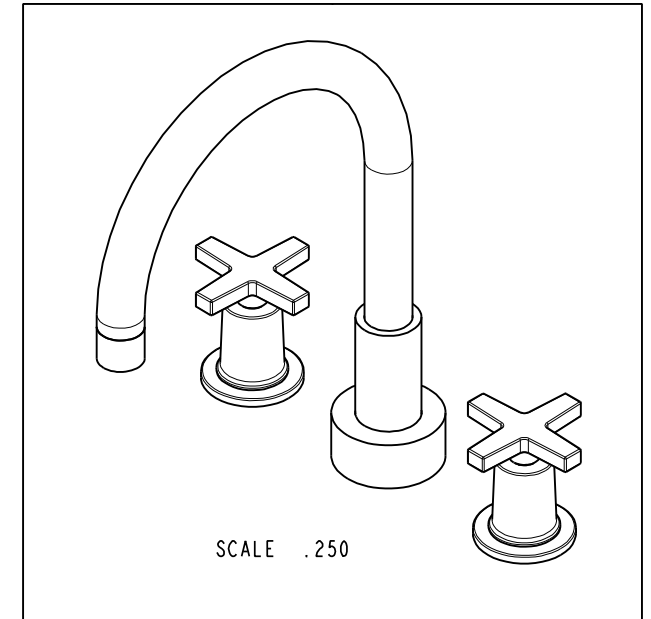
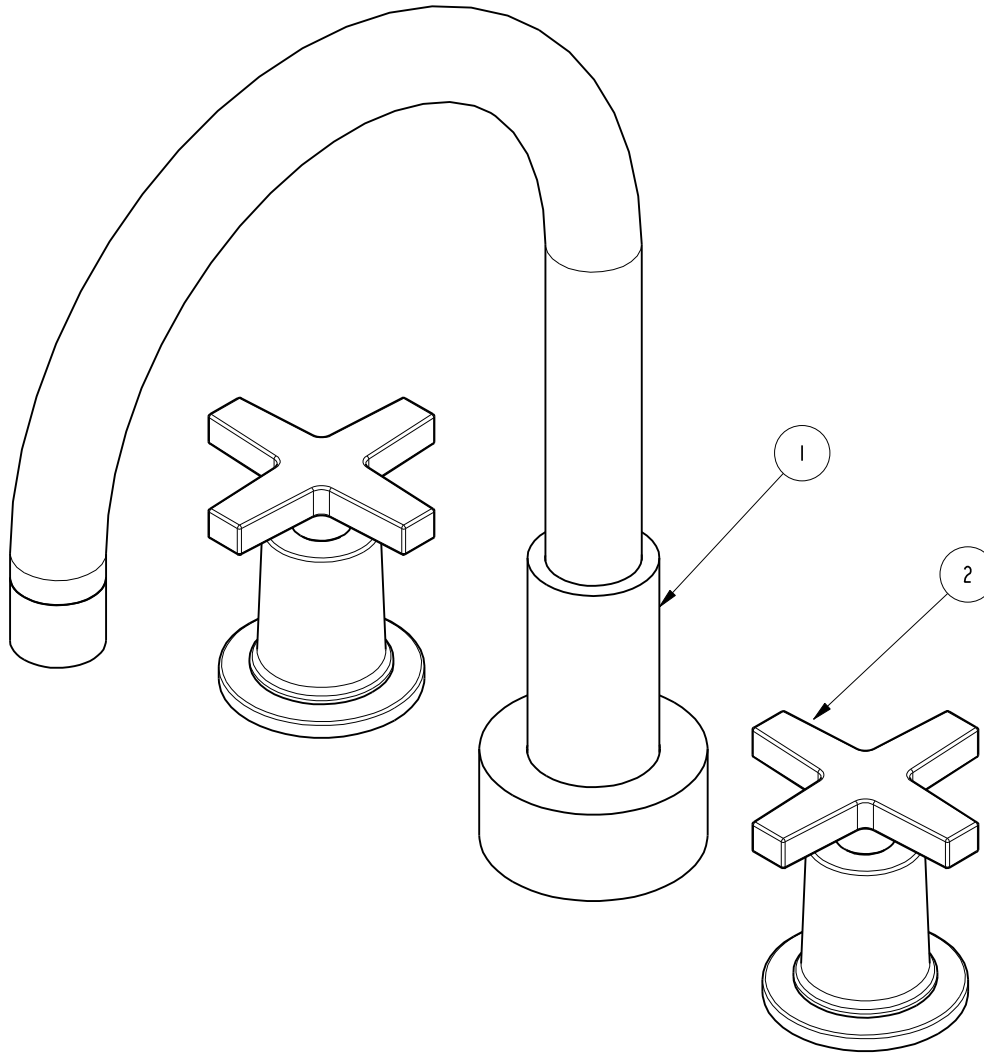

ZONE	REV	DESCRIPTION	DATE	APPROVED
-	A	EN-4300w	02/02/21	R.S.
-	-	EN-3041	07/27/16	J.M

COPYRIGHT 2005 BRASSTECH, INC. THESE DRAWINGS AND THE DESIGNS DEPICTED HEREIN ARE THE PROPRIETARY PROPERTY OF BRASSTECH. ANY USE OR REPRODUCTION IS SUBJECT TO THE EXPRESS APPROVAL OF BRASSTECH. UNAUTHORIZED USE IS STRICTLY PROHIBITED. ALL RIGHTS RESERVED.

TESTING	-	-	-
ASSEMBLY	-	-	-
PLATING	-	-	-
POLISHING	-	NEXT ASSY	USED ON
MACHINING	-	APPLICATION	
TOOLING FIXTURE #	REMOVE ALL BURRS AND SHARP EDGES		

UNITS ARE: INCHES [MM]  
TOLERANCES ARE:  
FRACTIONS DECIMALS ANGLES  
±1/16" .X ±.1 [2.5] ±1°  
.XX ±.06 [1.5]

(X.XXX) DENOTES CRITICAL DIMS.  
ALL THREADS ARE CRITICAL

DRAWN	JINSON	02/02/21
CHECKED	R.S.	02/02/21
APPROVED	R.S.	02/02/21

**BRASSTECH** 2001 CARNEGIE AVE.  
INCORPORATED SANTA ANA, CA 92705  
(949) 417-5207

ROMAN TUB FAUCET

DWG NO.	3-2986	REV	A
SCALE	.500	REF.	-
SHEET	1	OF	3

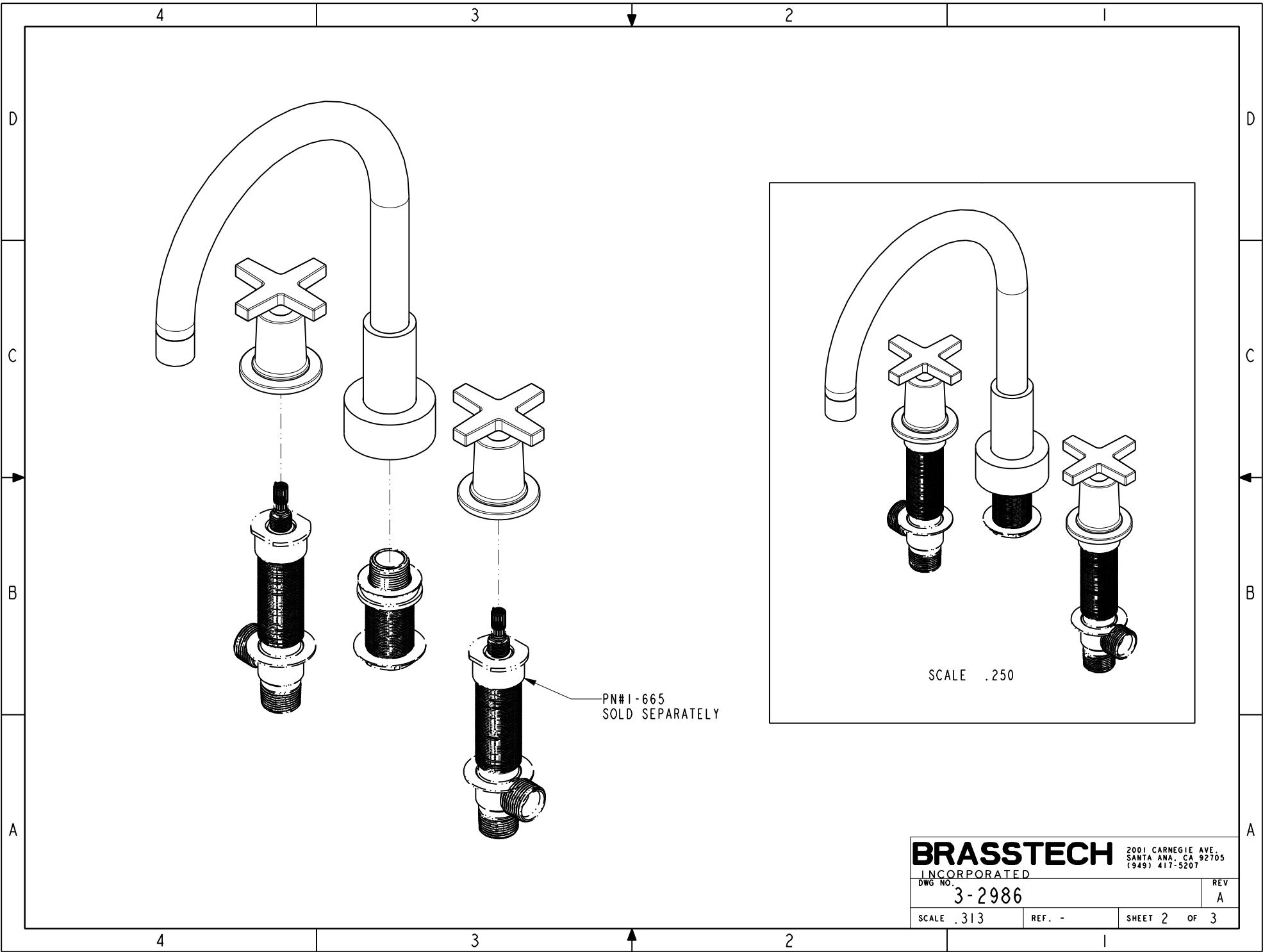

PN#1-665  
SOLD SEPARATELY

SCALE .250

<b>BRASSTECH</b>		2001 CARNEGIE AVE. SANTA ANA, CA 92705 (949) 417-5207	
INCORPORATED			
DWG NO.	3-2986	REV	A
SCALE .313	REF. -	SHEET 2 OF 3	

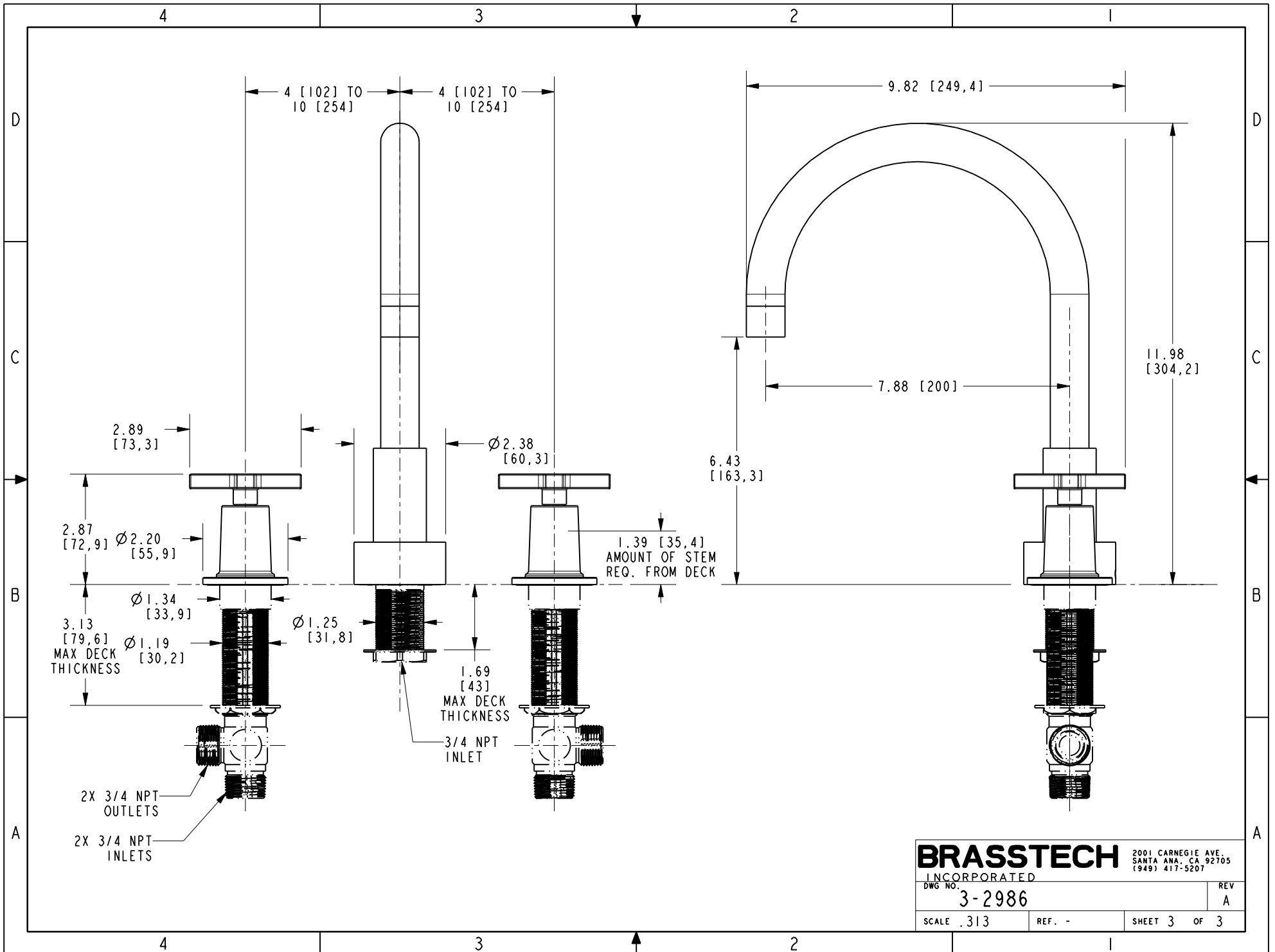

<b>BRASSTECH</b>		2001 CARNEGIE AVE. SANTA ANA, CA 92705 (949) 417-5207	
INCORPORATED			
DWG NO. 3-2986		REV A	
SCALE .313	REF. -	SHEET 3 OF 3	