

NOTES:

1. TO INSPECT ASSEMBLY, FOLLOW FIRST ARTICLE AND IN PROCESS INSPECTION SHEET.

2. BAG AND LABEL: "3-586 DIVERTER CROSS HANDLE".

BILL OF MATERIAL (CURRENT LEVEL)

ITEM	PT/ASSY	DESCRIPTION	TYPE	QTY.
1	2-941	R/T SPOUT ASM	ASSEMBLY	1
2	3-577	HANDLE CROSS/ ESC ASM	ASSEMBLY	2
3	3-586	DIVERTER CROSS HANDLE/ ESC ASM	ASSEMBLY	1
4	6-289-4	DECK FLANGE TRIM	ASSEMBLY	1
5	283-102	SQUARE WAND HANDSHOWER	ASSEMBLY	1
6	284	59 IN. SPIRAL SHOWER HOSE	ASSEMBLY	1

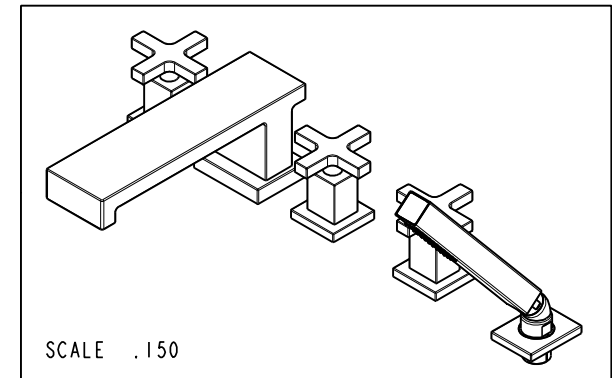
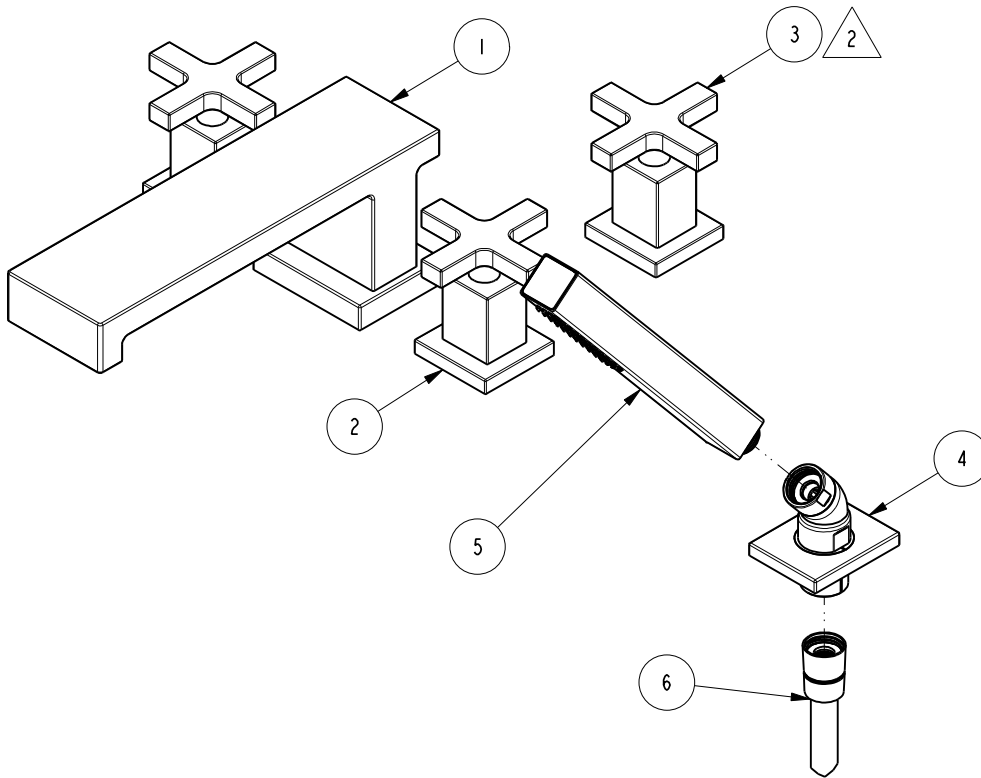

ZONE	REV	DESCRIPTION	DATE	APPROVED
-	B	EN-4300u	02/02/21	R.S.
-	A	EN-3397	06/04/18	J.A.
-	-	EN-3084c	10/05/16	AN

COPYRIGHT 2005 BRASSTECH, INC. THESE DRAWINGS AND THE DESIGNS DEPICTED HEREIN ARE THE PROPRIETARY PROPERTY OF BRASSTECH. ANY USE OR REPRODUCTION IS SUBJECT TO THE EXPRESS APPROVAL OF BRASSTECH. UNAUTHORIZED USE IS STRICTLY PROHIBITED. ALL RIGHTS RESERVED.

TESTING	-	-	-
ASSEMBLY	-	-	-
PLATING	-	-	-
POLISHING	-	NEXT ASSY	USED ON
MACHINING	-	APPLICATION	
TOOLING FIXTURE #	REMOVE ALL BURRS AND SHARP EDGES		

UNITS ARE: INCHES [MM]	
TOLERANCES ARE:	
FRACTIONS	DECIMALS
±1/16"	.X ±.1 [2.5]
	.XX ±.06 [1.5]
ANGLES ±°	
(X.XXX) DENOTES CRITICAL DIMS.	
ALL THREADS ARE CRITICAL	
DRAWN	JINSON 02/02/21
CHECKED	R.S. 02/02/21
APPROVED	R.S. 02/02/21

BRASSTECH 2001 CARNEGIE AVE. SANTA ANA, CA 92705 (949) 417-5207
INCORPORATED

ROMAN TUB FAUCET W/
HANDSHOWER

DWG NO. 3-2997 REV B

SCALE .250 REF. - SHEET 1 OF 3

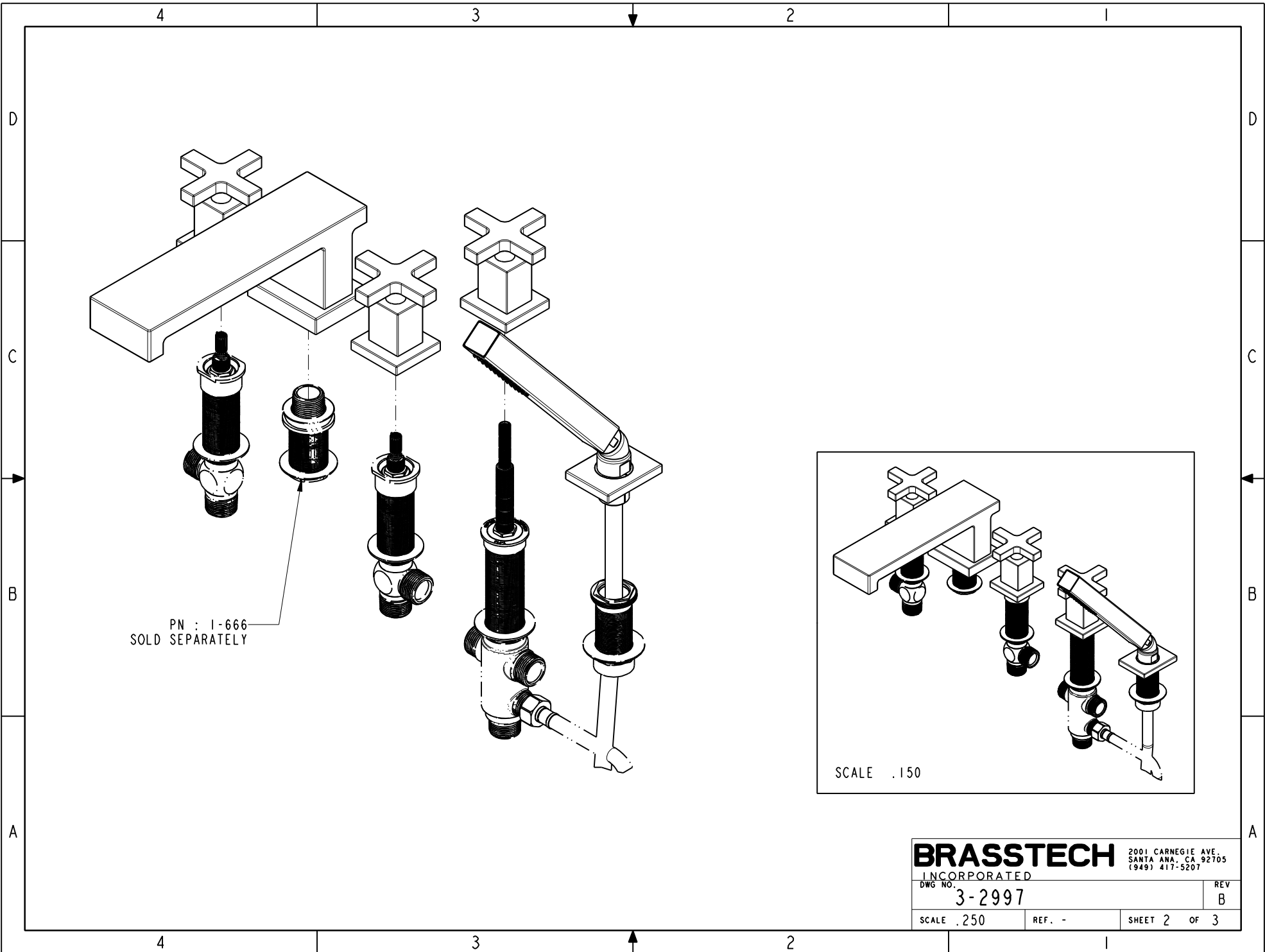

PN : 1-666
SOLD SEPARATELY

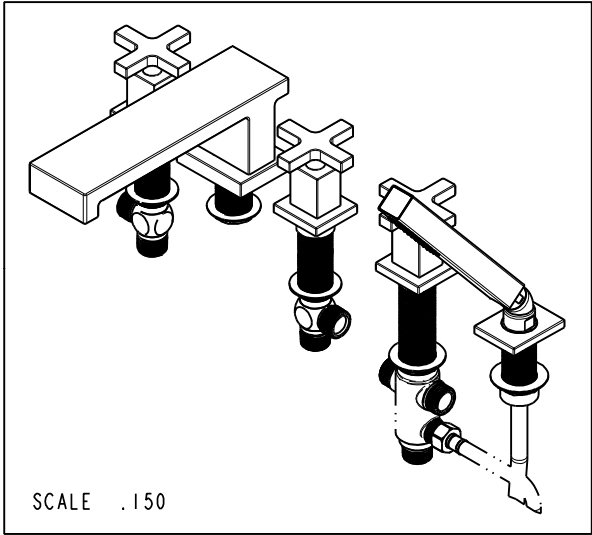

BRASSTECH 2001 CARNEGIE AVE.
INCORPORATED SANTA ANA, CA 92705
DWG NO. 3-2997 REV B
SCALE .250 REF. - SHEET 2 OF 3

