

NOTES:

1. TO INSPECT ASSEMBLY, FOLLOW FIRST ARTICLE AND IN PROCESS INSPECTION SHEET.

2. BAG AND LABEL: "3-576 DIVERTER HANDLE".

BILL OF MATERIAL (CURRENT LEVEL)

ITEM	PT/ASSY	DESCRIPTION	TYPE	QTY.
1	3-403	RT MITER SPOUT ASSY	ASSEMBLY	1
2	3-549	HANDLE/ ESC ASM	ASSEMBLY	2
3	3-576	HANDLE/ ESC ASM, DIVERTER	ASSEMBLY	1
4	6-289-7	HANDSHOWER-ESC ASM	ASSEMBLY	1
5	283-101	ROUND WAND HANDSHOWER	ASSEMBLY	1
6	284	59 IN. SPIRAL SHOWER HOSE	ASSEMBLY	1

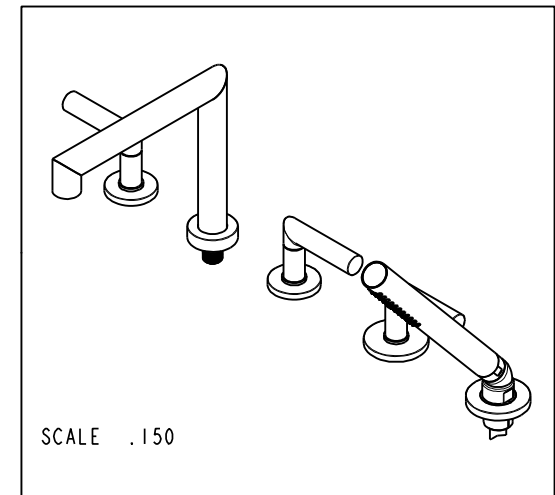
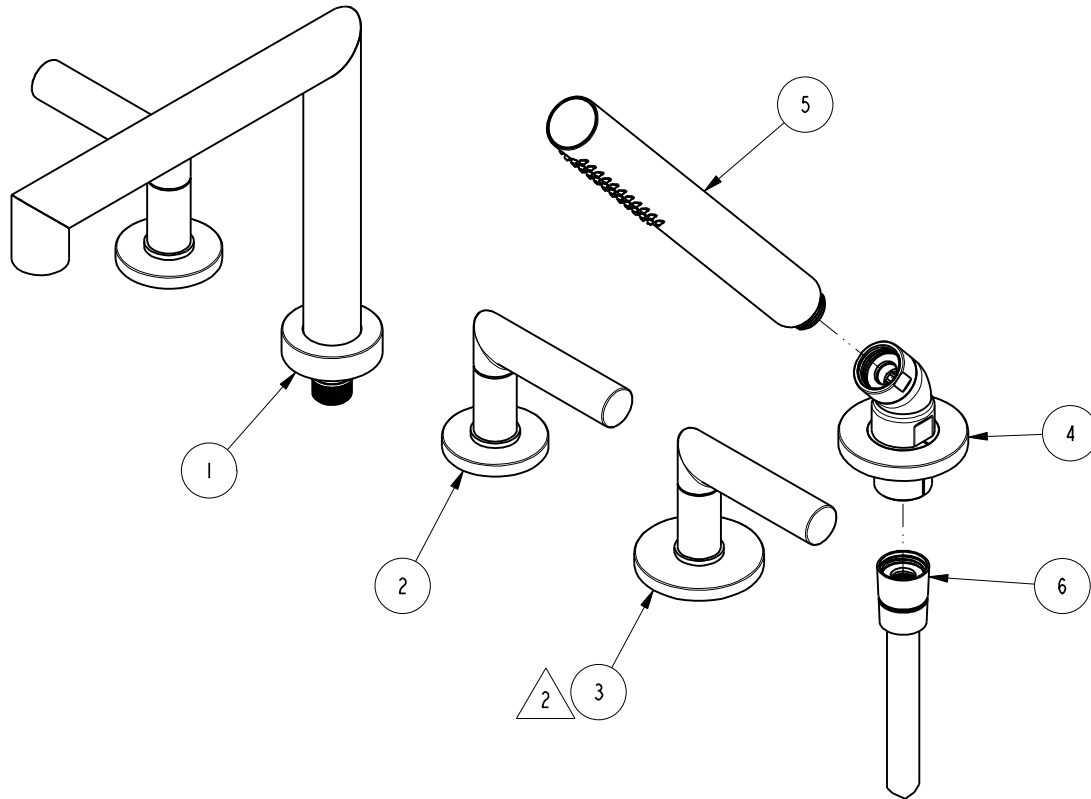

ZONE	REV	DESCRIPTION	DATE	APPROVED
-	B	EN-4300w	02/02/21	R.S.
-	A	EN-3397	06/05/18	J.A
-	-	EN-3032d	07/13/16	AN

COPYRIGHT 2005 BRASSTECH, INC. THESE DRAWINGS AND THE DESIGNS DEPICTED HEREIN ARE THE PROPRIETARY PROPERTY OF BRASSTECH. ANY USE OR REPRODUCTION IS SUBJECT TO THE EXPRESS APPROVAL OF BRASSTECH. UNAUTHORIZED USE IS STRICTLY PROHIBITED. ALL RIGHTS RESERVED.

TESTING	-	-	-
ASSEMBLY	-	-	-
PLATING	-	-	-
POLISHING	-	NEXT ASSY	USED ON
MACHINING	-	APPLICATION	
TOOLING FIXTURE #	REMOVE ALL BURRS AND SHARP EDGES		

UNITS ARE: INCHES [MM]		
TOLERANCES ARE:		
FRACTIONS	DECIMALS	ANGLES
±1/16"	.X ±.1 [2.5]	±°
	.XX ±.06 [1.5]	
(X.XXX) DENOTES CRITICAL DIMS.		
ALL THREADS ARE CRITICAL		
DRAWN	JINSON	02/02/21
CHECKED	R.S.	02/02/21
APPROVED	R.S.	02/02/21

BRASSTECH 2001 CARNEGIE AVE.
INCORPORATED SANTA ANA, CA 92705
(949) 417-5207

ROMAN TUB FAUCET W/
HANDSHOWER

DWG NO.	3-3127	REV	B
SCALE	.300	REF.	-
SHEET	1	OF	3

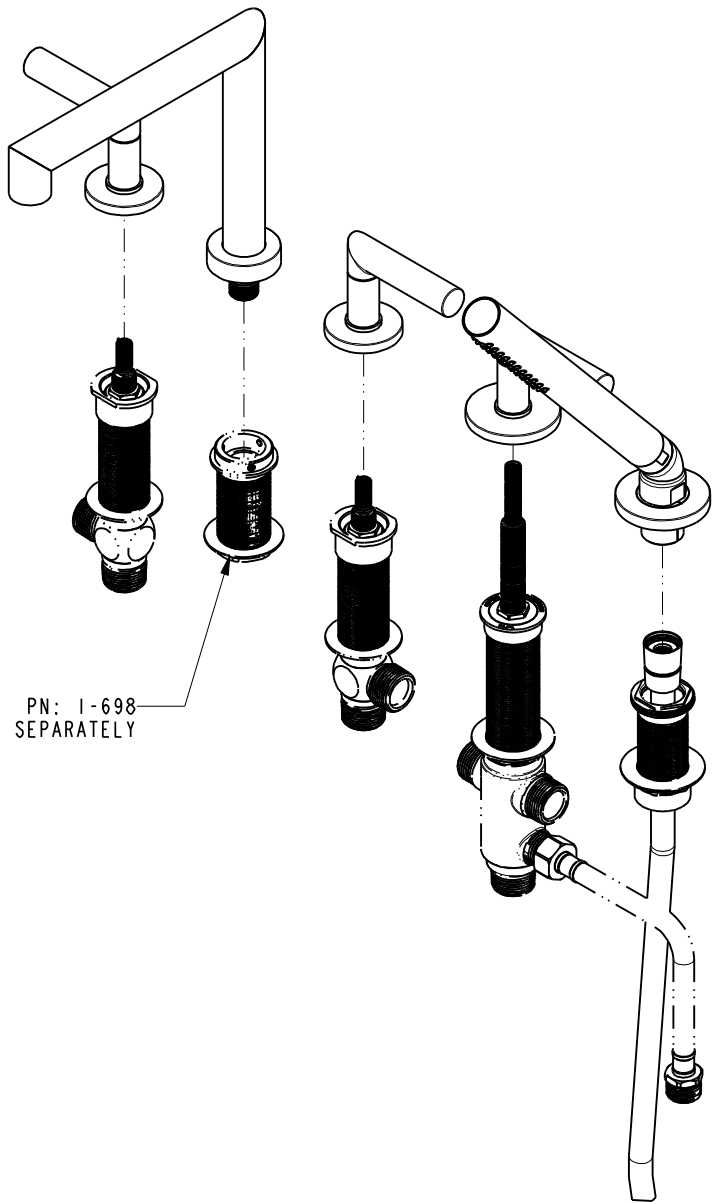

PN: 1-698
SOLD SEPARATELY

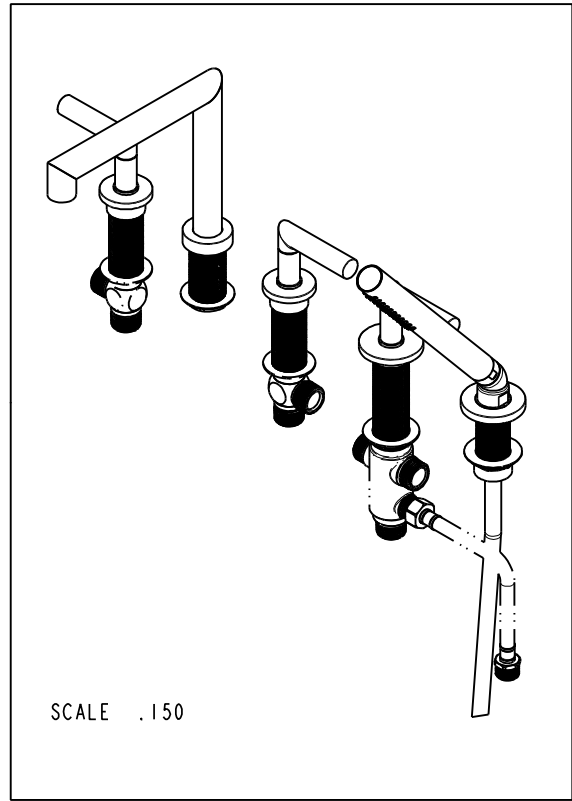

SCALE .150

BRASSTECH		2001 CARNEGIE AVE. SANTA ANA, CA 92705 (949) 417-5207	
INCORPORATED			
DWG NO. 3-3127		REV B	
SCALE .220	REF. -	SHEET 2 OF 3	

