

NOTES:

1. TO INSPECT ASSEMBLY, FOLLOW FIRST ARTICLE AND IN PROCESS INSPECTION SHEET.

BILL OF MATERIAL (CURRENT LEVEL)

ITEM	PT/ASSY	DESCRIPTION	TYPE	QTY.
1	20-300	LEVER ASM	ASSEMBLY	1
2	8-025	WIDESPREAD ESCUTCHEON BASE ASM	ASSEMBLY	1
3	92870	LEVER WRENCH	PART	1

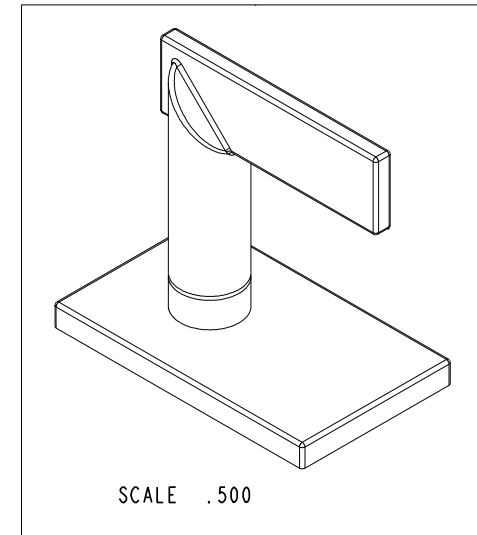
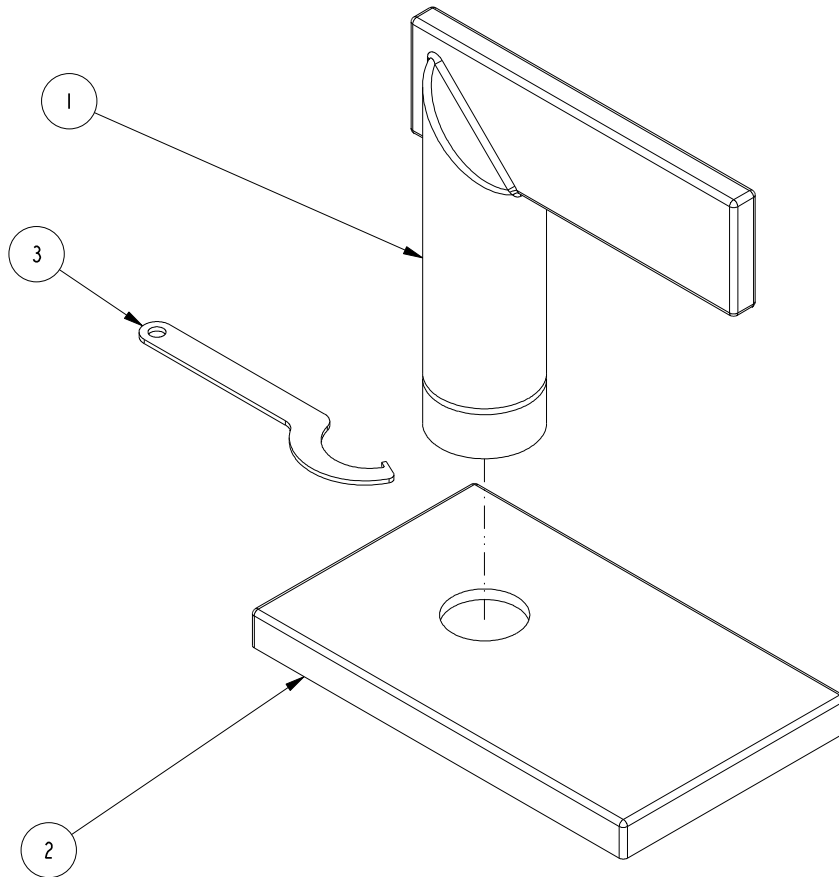

ZONE	REV	DESCRIPTION	DATE	APPROVED
-	B	EN-4300j	12/09/20	R.S.
-	A	EN-3334B	6/12/18	J.A.
-	-	EN-3334	8/30/17	J.A.

COPYRIGHT 2005 BRASSTECH, INC. THESE DRAWINGS AND THE DESIGNS DEPICTED HEREIN ARE THE PROPRIETARY PROPERTY OF BRASSTECH. ANY USE OR REPRODUCTION IS SUBJECT TO THE EXPRESS APPROVAL OF BRASSTECH. UNAUTHORIZED USE IS STRICTLY PROHIBITED. ALL RIGHTS RESERVED.

TESTING	ASSEMBLY	PLATING	POLISHING	MACHINING	TOOLING FIXTURE #	APPLICATION
-	-	-	-	-	-	-
-	-	-	-	-	2540	3-2541
-	-	-	-	-	NEXT ASSY	USED ON
-	-	-	-	-	REMOVE ALL BURRS AND SHARP EDGES	

UNITS ARE: INCHES [MM]	TOLERANCES ARE:
FRACTIONS DECIMALS ANGLES	$\pm 1/16"$.X $\pm .1$ [2.5] $\pm 1^\circ$
	.XX $\pm .06$ [1.5]
(X.XXX) DENOTES CRITICAL DIMS.	
ALL THREADS ARE CRITICAL	
DRAWN	JIMSON 12/09/20
CHECKED	R.S. 12/09/20
APPROVED	R.S. 12/09/20

BRASSTECH 2001 CARNEGIE AVE. SANTA ANA, CA 92705 (949) 417-5207
INCORPORATED

LEVER HANDLE ASM

DWG NO. **3-609** REV **B**

SCALE .750 REF. - SHEET 1 OF 2

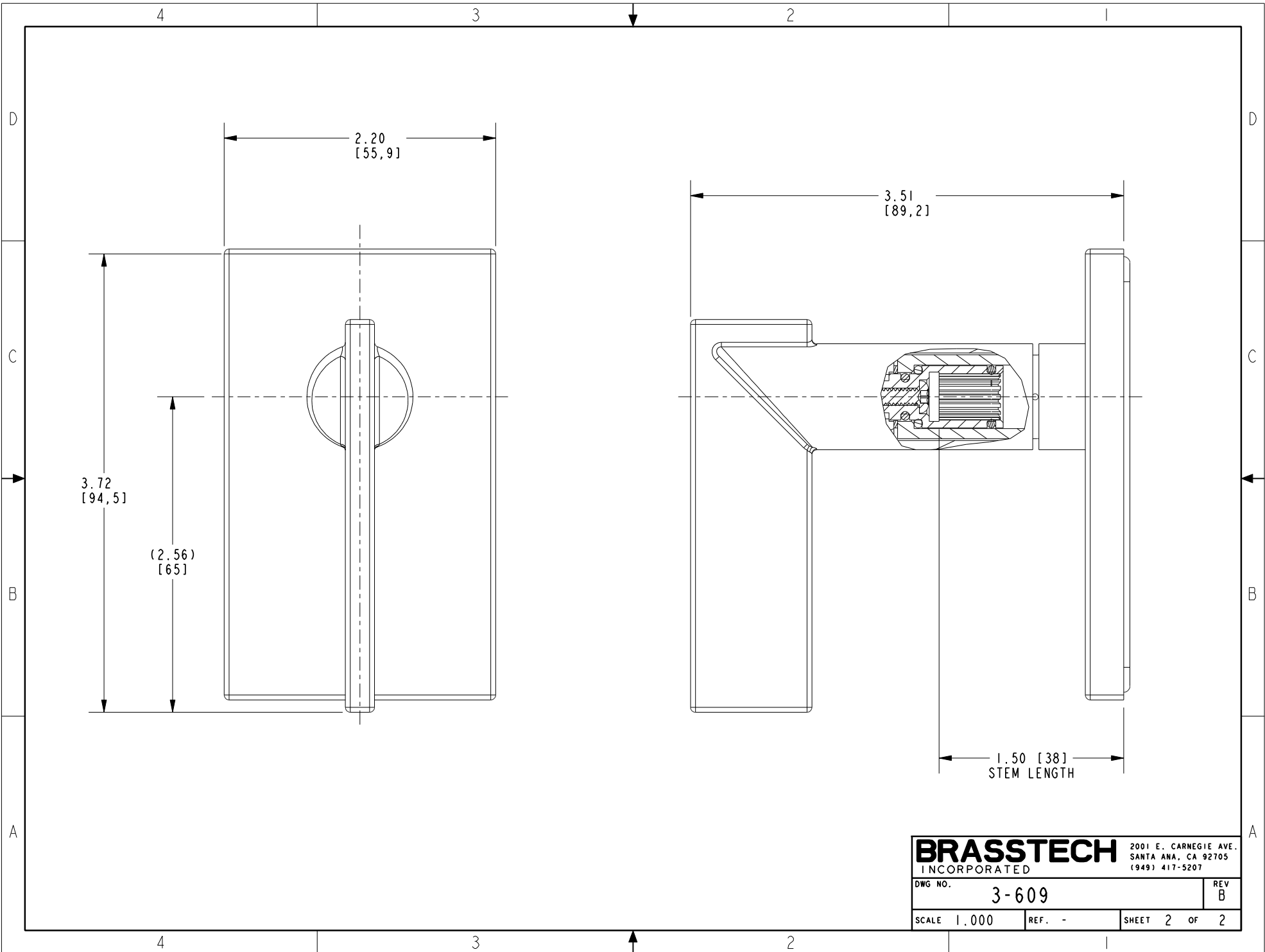

BRASSTECH		2001 E. CARNEGIE AVE. SANTA ANA, CA 92705 (949) 417-5207	
DWG NO.	3-609	REV	B
SCALE	1.000	REF.	-
		SHEET	2 OF 2