

NOTES:

- (NI) 1. TO INSPECT ASSEMBLY, FOLLOW FIRST ARTICLE AND IN PROCESS INSPECTION SHEET.

BILL OF MATERIAL (CURRENT LEVEL)

ITEM	PT/ASSY	DESCRIPTION	TYPE	QTY.
1	20-565	ESCUTCHEON ASM	ASSEMBLY	1
2	20-567	CROSS HANDLE ASM	ASSEMBLY	1

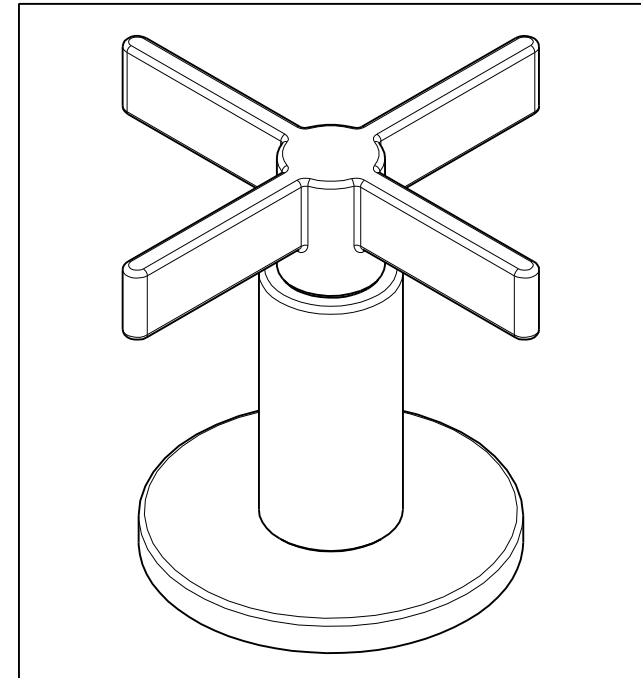
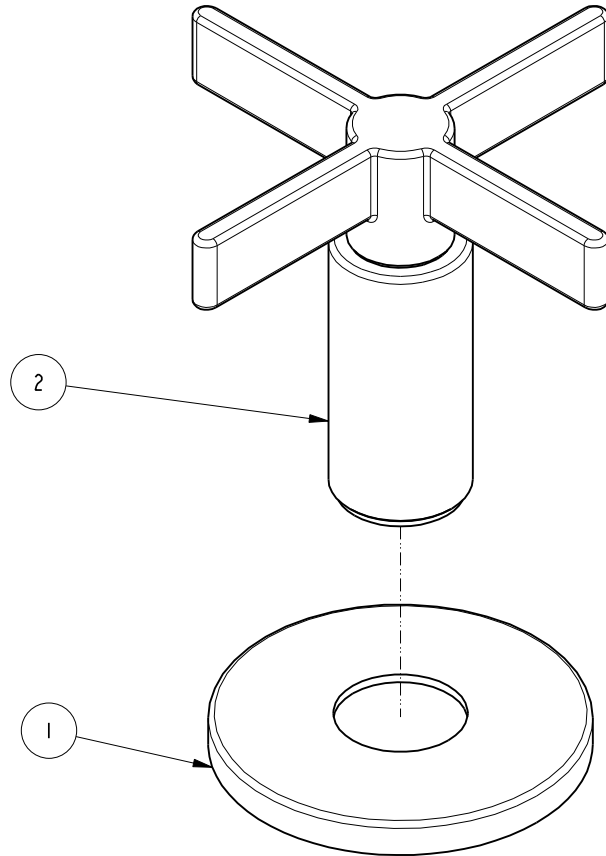

COPYRIGHT 2005 BRASSTECH, INC. THESE DRAWINGS AND THE DESIGNS DEPICTED HEREIN ARE THE PROPRIETARY PROPERTY OF BRASSTECH. ANY USE OR REPRODUCTION IS SUBJECT TO THE EXPRESS APPROVAL OF BRASSTECH. UNAUTHORIZED USE IS STRICTLY PROHIBITED. ALL RIGHTS RESERVED.

TESTING	-	-	-
ASSEMBLY	-	-	-
PLATING	-	3330	3330
POLISHING	-	NEXT ASSY	USED ON
MACHINING	-	APPLICATION	
TOOLING FIXTURE #		REMOVE ALL BURRS AND SHARP EDGES	

UNITS ARE: INCHES [MM]		
TOLERANCES ARE:		
FRACTIONS DECIMALS	ANGLES	
±1/16"	±°	
.X ±.1 [2.5]		
.XX ±.06 [1.5]		
(X.XXX) DENOTES CRITICAL DIMS. ALL THREADS ARE CRITICAL		
DRAWN	JINSON	08/24/20
CHECKED	J.M.	08/24/20
APPROVED	J.M.	08/24/20

BRASSTECH 2001 CARNEGIE AVE.
INCORPORATED SANTA ANA, CA 92705
(949) 417-5207

CROSS HANDLE W/ESC.

ZONE	REV	DESCRIPTION	DATE	APPROVED
-	-	EN-3934	08/24/20	J.M.

DWG NO.	3-722	REV	-
SCALE	1.000	REF.	-
SHEET		OF	