

NOTES:

- (N1) 1. TO INSPECT ASSEMBLY, FOLLOW FIRST ARTICLE AND IN PROCESS INSPECTION SHEET.
- 2. APPLY LIGHT FILM OF DOW CORNING 111 SILICONE COMPOUND.

BILL OF MATERIAL (CURRENT LEVEL)

ITEM	PT/ASSY	DESCRIPTION	TYPE	QTY.
1	20-621	W/M SPOUT	ASSEMBLY	1
2	20-578	W/M SPOUT BASE ASM	ASSEMBLY	1
3	1-368	WALL MOUNT SPOUT ADAPTOR ASM	ASSEMBLY	1
4	2-403	STREAM STRAIGHTENER JR ASSY	ASSEMBLY	1

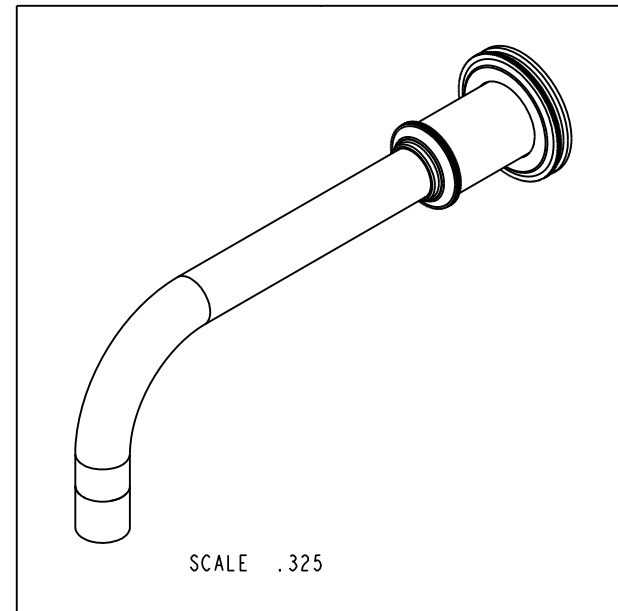
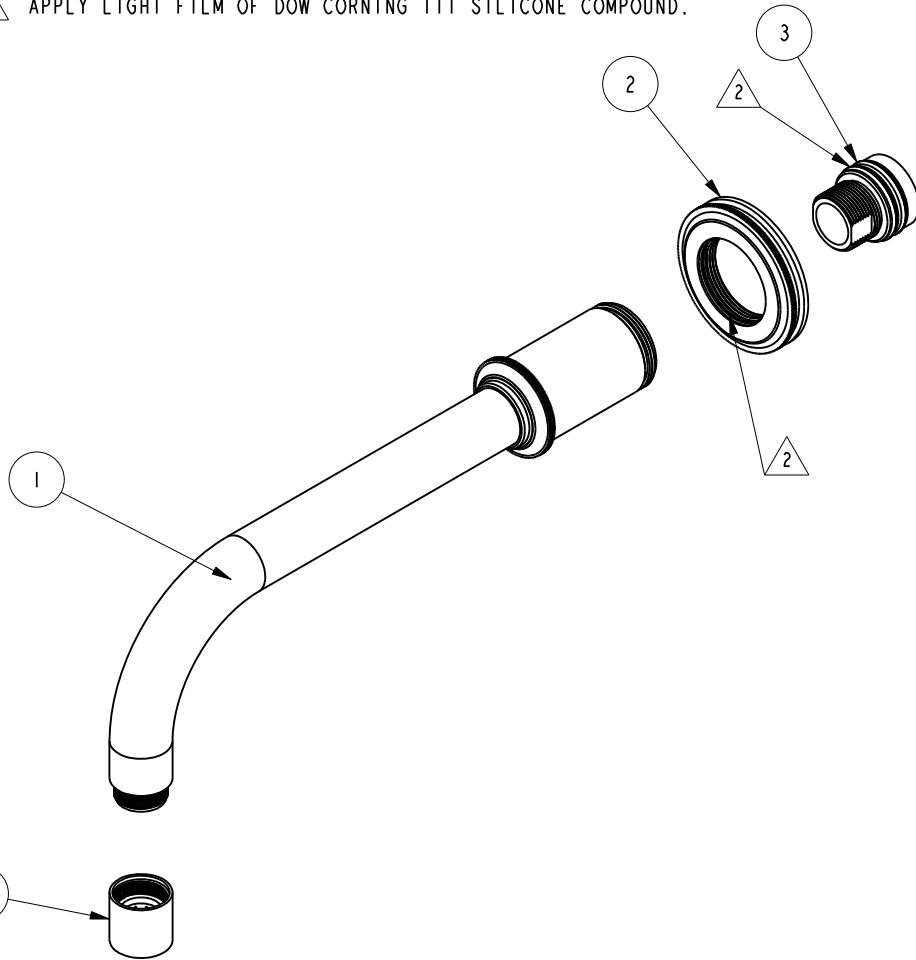

TESTING	-	-	-
ASSEMBLY	-	-	-
PLATING	-	3-2945	3-2945
POLISHING	-	NEXT ASSY	USED ON
MACHINING	-	APPLICATION	
TOOLING FIXTURE #		REMOVE ALL BURRS AND SHARP EDGES	

BRASSTECH 2001 CARNEGIE AVE.
INCORPORATED SANTA ANA, CA 92705
(949) 417-5207

W/M TUB SPOUT W/ESC.

DWG NO. **3-729** REV **A**

SCALE .375 REF. - SHEET | OF |

COPYRIGHT 2005 BRASSTECH, INC. THESE DRAWINGS AND THE DESIGNS DEPICTED HEREIN ARE THE PROPRIETARY PROPERTY OF BRASSTECH. ANY USE OR REPRODUCTION IS SUBJECT TO THE EXPRESS APPROVAL OF BRASSTECH. UNAUTHORIZED USE IS STRICTLY PROHIBITED. ALL RIGHTS RESERVED.

ZONE	REV	DESCRIPTION	DATE	APPROVED
-	A	EN-4352-1	07/07/21	J.M.
-	-	EN-4257	11/16/20	J.M.