

NOTES:

(N1) 1. FIT / FORM / FUNCTION SHALL FOLLOW PS-E.008.

BILL OF MATERIAL (CURRENT LEVEL)

ITEM	PT/ASSY	DESCRIPTION	TYPE	QTY.
1	2-224	COVERPLATE BP W/DIVERTER	ASSEMBLY	1
2	1-595	BP VALVE ASM W/ DIVERTER	ASSEMBLY	1
3	2-217	DIVERTER TRIM KIT	ASSEMBLY	1
4	206	SHOWER ARM FLANGE	PART	1
5	200	SHOWER ARM 6" BRASS	PART	1
6	10016	ESCUTCHEON BELL	PART	1
7	2-517	WALL TUB SPOUT	ASSEMBLY	1
8	91231	O-RING, #2-136, EPDM, 65-75 DURO	PART	1
9	212	SHOWER HEAD	ASSEMBLY	1

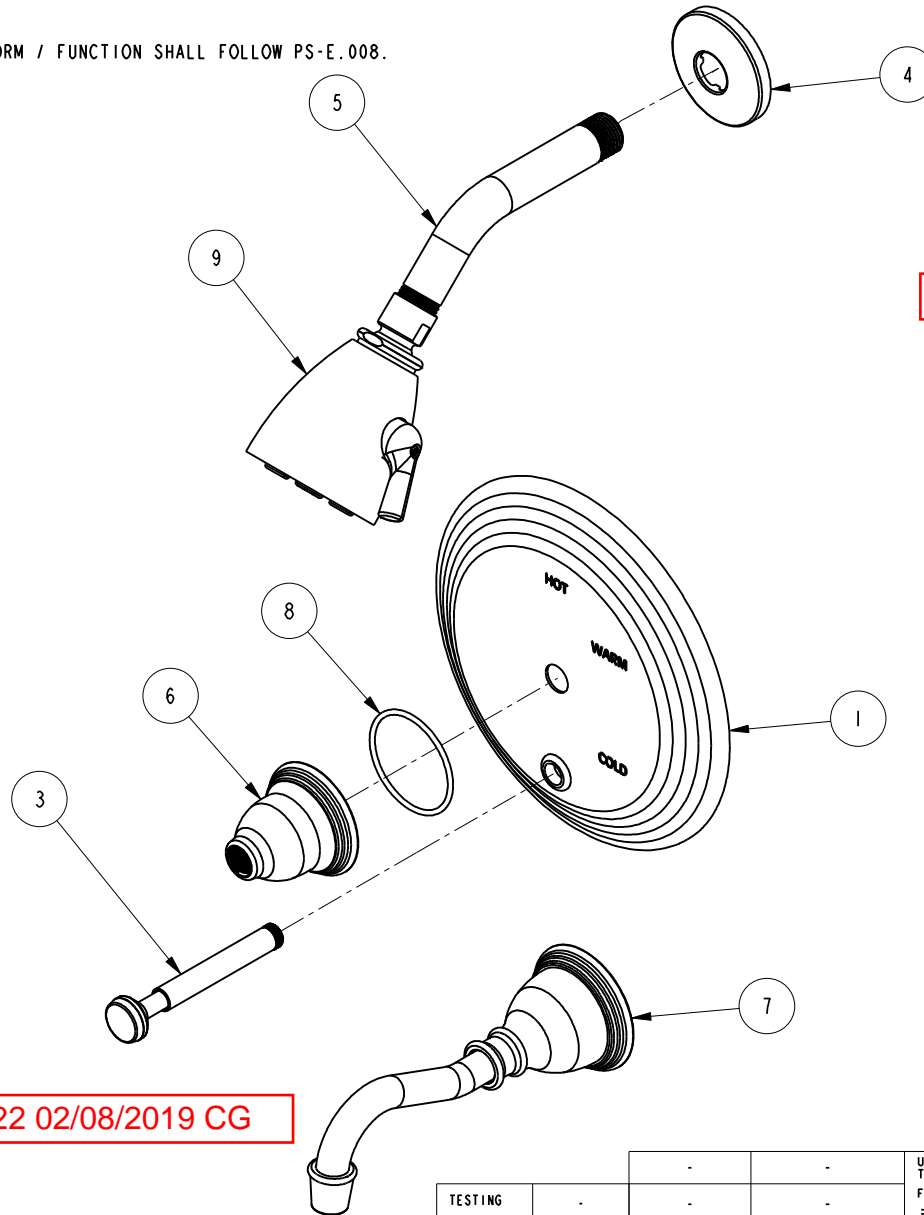

91753

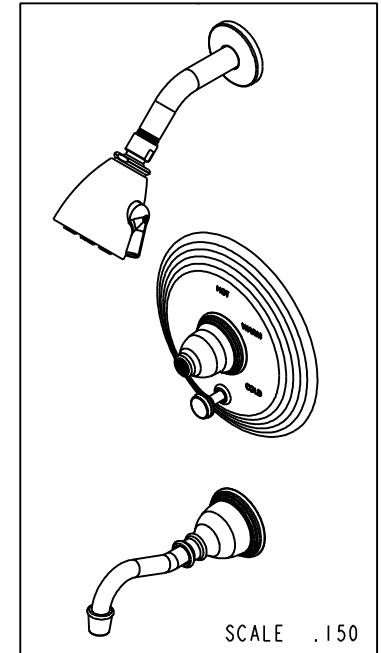

REV D EN-3722 02/08/2019 CG

ZONE	REV	DESCRIPTION	DATE	APPROVED
-	C	EN-3113	08/12/16	J.A
-	B	EN-2348b	12/20/13	-
-	A	EN-1582	07/12/10	-
-	-	EO-0554	08/15/05	-

COPYRIGHT 2005 BRASSTECH, INC. THESE DRAWINGS AND THE DESIGNS DEPICTED HEREIN ARE THE PROPRIETARY PROPERTY OF BRASSTECH. ANY USE OR REPRODUCTION IS SUBJECT TO THE EXPRESS APPROVAL OF BRASSTECH. UNAUTHORIZED USE IS STRICTLY PROHIBITED. ALL RIGHTS RESERVED.

TESTING	-	-	-
ASSEMBLY	-	-	-
PLATING	-	-	-
POLISHING	-	NEXT ASSY	USED ON
MACHINING	-	APPLICATION	
TOOLING	FIXTURE #	REMOVE ALL BURRS AND SHARP EDGES	

UNITS ARE: INCHES [MM]
TOLERANCES ARE:
FRACTIONS DECIMALS ANGLES
±1/16" .X ±.1 [2,5] ±1°
.XX ±.06 [1,3]
(X.XXX) DENOTES CRITICAL DIMS.
ALL THREADS ARE CRITICAL
DRAWN VINAY 08/12/16
CHECKED RAVINDRA 08/12/16
APPROVED J.A 08/12/16

BRASSTECH 2001 CARNEGIE AVE. SANTA ANA, CA 92705 (949) 417-5207
INCORPORATED
TUB / SHOWER SET - BP
DWG NO. 3-7302
SCALE .275 REF. - SHEET | OF 5
REV **D**

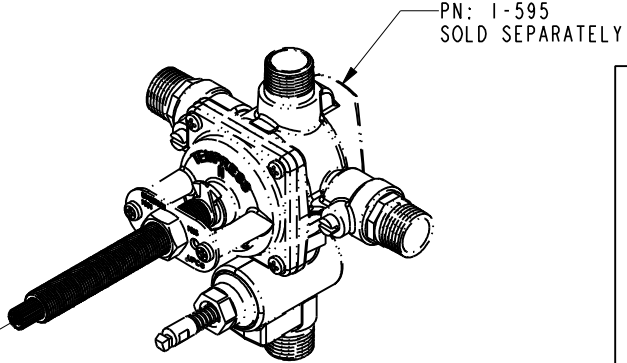
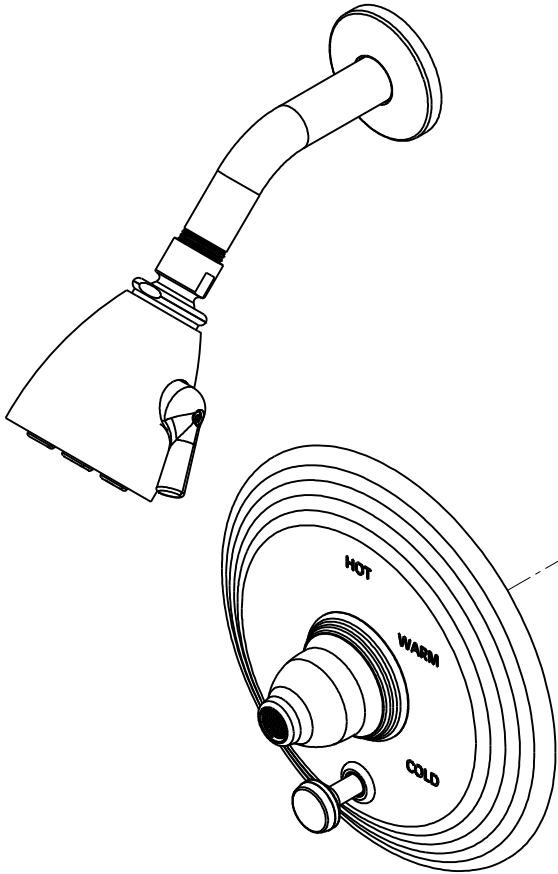

PN: 1-595
SOLD SEPARATELY

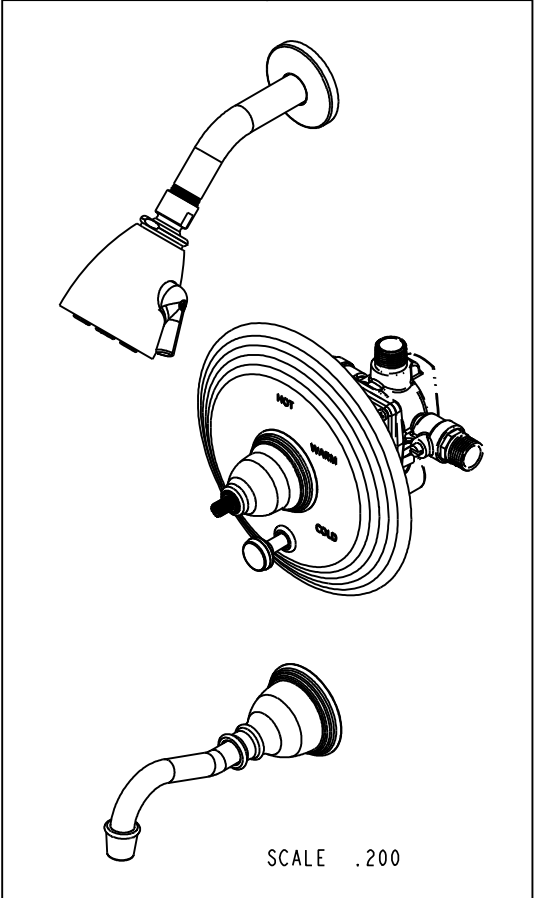

SCALE .200

BRASSTECH 2001 E. CARNEGIE AVE.
INCORPORATED SANTA ANA, CA 92705
(949) 417-5207

DWG NO.	3-7302	REV	C
---------	--------	-----	---

SCALE .313	REF. -	SHEET 2 OF 3
------------	--------	--------------

NOTES:

- 1. CUT STEM TO DIMENSION SHOWN.
- 2. CUT ALL-THREAD 3/4" SHORTER THAN STEM.

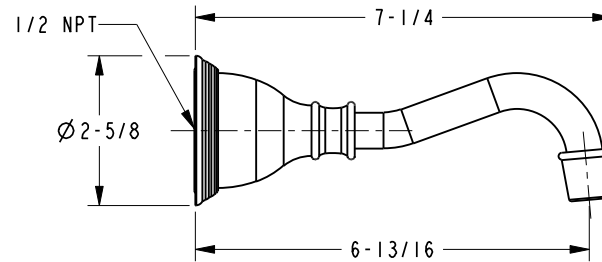
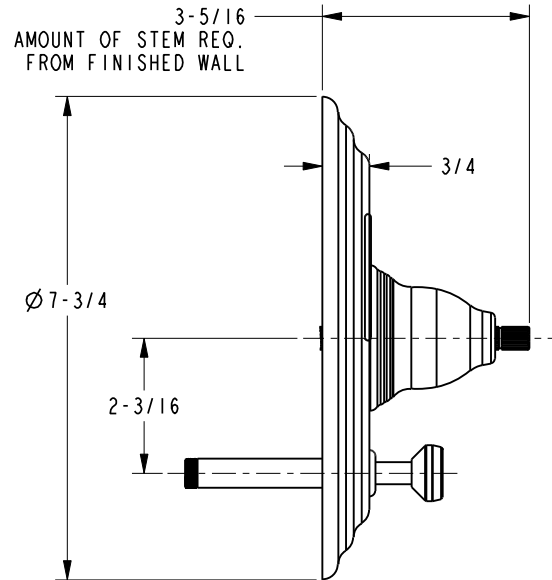
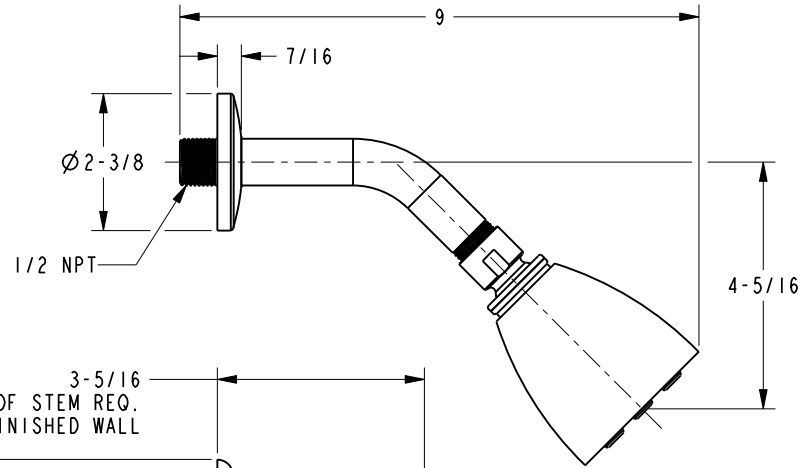
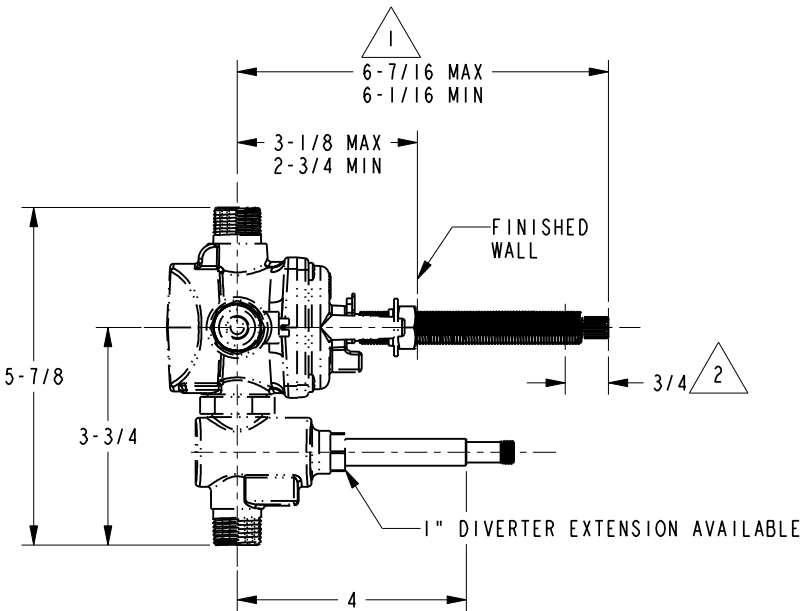
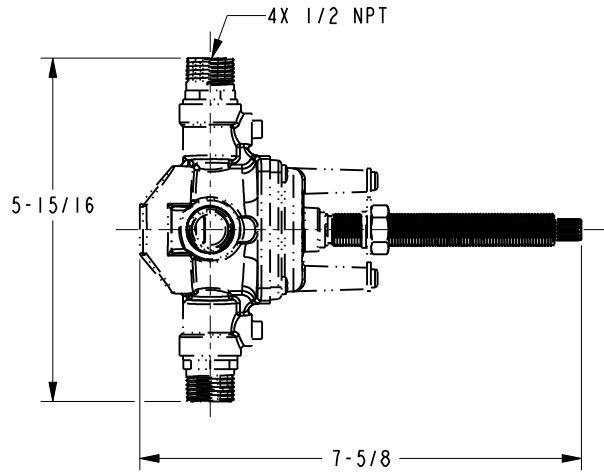

BRASSTECH		2001 E. CARNEGIE AVE.	
INCORPORATED		SANTA ANA, CA 92705	
		(949) 417-5207	
DWG NO.	3-7302	REV	C
SCALE	.300	REF.	-
		SHEET	3 OF 3